

# DOCTORAL THESIS

## Carbon Fibre Reinforced Polymers for Strengthening of Structural Elements

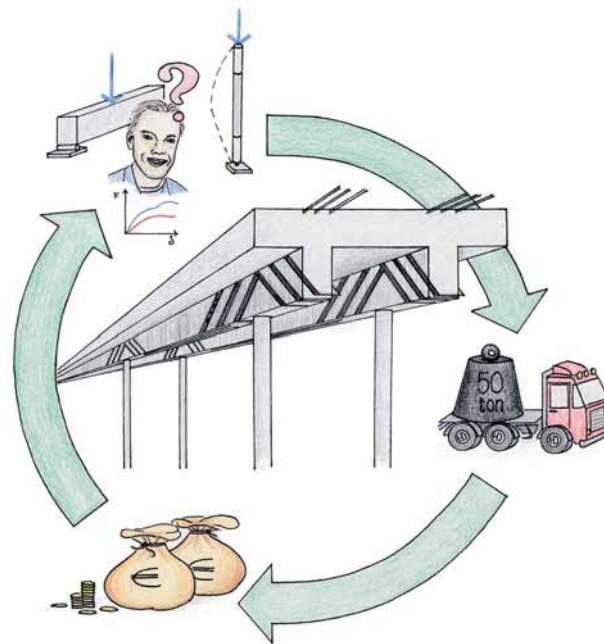

ANDERS CAROLIN

Department of Civil and Mining Engineering  
Division of Structural Engineering

ISBN: 91-89580-04-4 • 2003:18 • ISSN: 1402 - 1544 • ISRN: LTU - DT - - 03/18 - - SE





DOCTORAL THESIS 2003:18

CARBON FIBRE REINFORCED POLYMERS  
FOR STRENGTHENING OF  
STRUCTURAL ELEMENTS

ANDERS CAROLIN

Division of Structural Engineering  
Department of Civil and Mining Engineering  
Luleå University of Technology  
SE - 971 87 Luleå  
Sweden  
<http://www.ce.luth.se/>

Carbon Fibre Reinforced Polymers for Strengthening of Structural Elements

ANDERS CAROLIN

*Avd för Konstruktionsteknik*

*Institutionen för Väg- och Vattenbyggnad*

*Luleå tekniska universitet*

### **Akademisk avhandling**

som med vederbörligt tillstånd av Tekniska fakultetsnämnden vid Luleå tekniska universitet för avläggande av teknologie doktorsexamen, kommer att offentligt försvaras i

universitetssal F1031, torsdagen den 12 juni 2003, kl 10.00

Fakultetsopponent: *Professor Kenneth Neale, Université de Sherbrooke, Kanada*

ISBN: 91-89580-04-4

ISSN 1402-1544

Doctoral Thesis 2003:18

ISRN: LTU-DT—03/18--SE

Front page:

The Illustration on the front page shows in the centre a bridge that has been strengthened with CFRPs in several aspects. The main girders, between columns, have been strengthened with laminates bonded to the surface to carry higher positive moments. Over the Columns, the girders have been strengthened with Near Surface Mounted Reinforcement (NSMR) to carry higher negative moments. Close to the columns, the main girders have also been strengthened to carry higher shear loads. This has been achieved by wrapping the girders with Carbon Fibre Reinforced Polymer (CFRP) fabrics and anchoring them securely in the tension zone.

Encircling the bridge: a small amount of money (the coins), that is invested in research (myself?), may develop strengthening methods so that structures will be able to carry higher loads (the overloaded truck), and this saves big money for the society (bags of money), of which a part should be investigated in further research.

Artist: Helena Johnsson

## PREFACE

This thesis is based on research carried out between 1998 and 2003 at the Division of Structural Engineering, the Department of Civil and Mining Engineering at Luleå University of Technology (LTU). During May to October 2000 research was carried out at University of California, San Diego, Structural Department. The financial support has been provided by The Development Fund of the Swedish Construction Industry (SBUF), The Swedish Road Administration (Vägverket), The Swedish Rail Administration (Banverket), “Lars Erik Lundbergs stiftelse för forskning och utbildning”, Teracom AB, and J. Gust Richerts foundation. Skanska AB has also contributed to the work presented in this thesis by providing interesting projects and fruitful collaboration.

I would like to thank my supervisor Prof. Björn Täljsten for never-ceasing energy and positive manner. Your many ideas are appreciated as well as your interest in mine. Thanks to Prof. Lennart Elfgren and Prof. Thomas Olofsson the leaders of the Division, for all your advice and support during the work.

Many thanks are also due the staff at Testlab for all their help with my tests and measurements. Special attention should be given to Håkan Johansson, Georg Danielsson and Lars Åström for their late night work helping with the oddest ideas.

All the staff at the Department of Civil & Mining Engineering, specially the staff at the Division of Structural Engineering, are appreciated for being such good colleagues. Special thanks, to the PhD-students of structural engineering and the “Thomas-and-Björn-Amoeba” for laughter and highly informal discussion. Thanks to Helena Johnsson at Steel Structures for your beautiful illustration on the front page.

Further, I am grateful to Abderahim Abouddrar, Anders Johansson, Peter Mattsson, Jon Rødsætre, Mattias Clarin and Andy Hägglund for your hard laboratory work during your Master Theses.

Mom, Dad and my brother, I would like to thank you very much for always supporting and being there for me.

Finally, I would like to express my greatest gratitude to my fiancée Helena for your support and sacrifices during my studies. I love you darling.

Luleå, 5<sup>th</sup> of May 2003

Anders Carolin

## SUMMARY

There is a large need for strengthening of concrete structures all around the world and there can be many reasons for strengthening, increased loads, design and construction faults, change of structural system, and so on. The need exists for strengthening in flexure as well as in shear. Epoxy plate bonding with Carbon Fibre Reinforced Polymers, CFRPs has been shown to be a competitive method for strengthening of existing structures and increasing the load bearing capacity.

When applying composites for increased shear capacity, special consideration needs to be taken for design with the truss model. A limitation factor of approximately 0.6 must be used due to linear elastic behaviour of the composite. The limitation factor is analytically derived and verified by tests on 4.5 m long beams. When limitation on maximum strain in concrete is applied, the allowable strain in the composite will be even lower due to anisotropy and divergence in fibre and principal strain direction.

By bonding CFRP to a structure in sawn grooves, Near Surface Mounted Reinforcement (NSMR), some advantages compared to traditional plate bonding may be achieved. The reinforcement will get some protection, installation may be easier and quality may be improved. The rods can for some situation also be bonded by grout. Laboratory tests show that a significant strengthening effect may be achieved.

By laboratory tests of 4 m long beams, the thesis also shows that a structure may be strengthened with live loads during the strengthening process. This holds both for NSMR and traditional laminate bonding.

Normally, in strengthening applications CFRPs are used as additional tensile reinforcement. The thesis shows how CFRP plate bonding may be used for strengthening of increase buckling load-bearing capacity for steel members subjected to compression. A design proposal, compared to full-scale tests, is presented for this application.

Suggestions for further research are identified and presented.

Keywords: concrete, carbon fibre reinforced polymers, CFRP, plate bonding, laminates, strengthening, bridges, shear, bending, near surface mounted, NSM, laboratory tests, steel, buckling.



## SAMMANFATTNING (IN SWEDISH)

Över hela världen finns ett stort behov av förstärkning av betongkonstruktioner. Det kan finnas flera orsaker till att förstärkning behövs: ökande laster, konstruktions- och utförandefel, ändring av ett statiskt system, och så vidare. Behov finns för förstärkning såväl i böjning som i tvärkraft. Utanpåliggande förstärkning med kolfiberkomposit har visat sig vara en konkurrenskraftig metod för förbättring av befintliga konstruktioner.

Vid förstärkning för ökad tvärkraftskapacitet måste särskild hänsyn tas vid dimensionering med fackverksmodell. En begränsningsfaktor om ungefär 0,6 måste användas pga linjärelastiskt betende. Begränsningsfaktorn är analytiskt bestämd och verifierad mot försök på 4,5 m långa balkar. När den maximalt tillåtna töjningen i betongen är begränsande faktor måste den tillåtna töjningen i kompositen reduceras på grund av anisotropi och avvikelse mellan fiberriktningen och största huvudtöjningsriktningen.

Genom att limma kolfiberkomposit i frästa spår kan en del fördelar nå jämfört med klassisk förstärkning med utanpåliggande komposit. Förstärkningen blir i viss mån skyddad, utförandet kan bli enklare och kvaliteten kan förbättras. I vissa fall kan kompositen fästas med bruk. Laboratorieförsök visar att en signifikant förstärkningseffekt kan uppnås.

Genom laboratorieförsök med 4 m långa balkar, visas i avhandlingen att det är möjligt att förstärka konstruktioner med rörliga laster under förstärkningsprocessen. Detta gäller både för komposit i frästa spår och för det traditionella där kompositen limmas på ytan.

Vanligtvis, vid förstärkning med komposit används denna som extra dragarmering. Avhandlingen visar att utanpåliggande komposit också kan användas för att öka den lastbärande förmågan för konstruktionsdelar begränsade av knäckning. Ett förslag till dimensioneringsregler är presenterat för denna typ av förstärkning.

Förslag till fortsatt forskning identifieras och presenteras.

Nyckelord: betong, kolfiber, utanpåliggande armering, förstärkning, broar, tvärkraft, böjning, infräst förstärkning, laboratorieförsök, stål, knäckning

## TABLE OF CONTENTS

PREFACE .....	III
SUMMARY .....	V
SAMMANFATTNING (IN SWEDISH) .....	VII
TABLE OF CONTENTS .....	IX
1 INTRODUCTION .....	1
1.1 Background and problem identification .....	1
1.1.1 Aims .....	3
1.1.2 Limitations .....	3
1.2 Description of thesis content .....	3
2 STRENGTHENING .....	5
2.1 Challenges .....	5
2.2 Ductility .....	6
2.3 Strategies for strengthening .....	6
2.4 Partial coefficients .....	8
2.4.1 Load effect .....	9
2.4.2 Load bearing capacity .....	9
2.4.3 Risk of failure .....	10
3 FIBRE REINFORCED POLYMERS .....	13
3.1 Composite components .....	13
3.1.1 Fibres .....	13

---

3.1.2	Matrices.....	15
3.2	Composites .....	15
3.2.1	Mechanical properties .....	16
3.2.2	Durability .....	18
3.3	Environmental aspects.....	18
4	PLATE BONDING .....	19
4.1	Steel plate bonding .....	19
4.2	FRP Plate bonding.....	20
4.2.1	Introduction .....	20
4.2.2	Preparation .....	21
4.2.3	FRP bonding.....	23
4.2.4	Completion.....	24
4.2.5	Quality verification .....	24
4.2.6	Advantages and disadvantages.....	25
4.3	Undertaken projects and full-scale tests .....	25
4.3.1	The Kallkällan Bridge .....	26
4.3.2	Shear strengthening of T-beams.....	30
4.3.3	Gröndal and Alvik Bridges .....	31
4.3.4	Concrete overhead crane main girders .....	33
5	RESEARCH AREAS .....	35
5.1	General .....	35
5.2	Shear.....	35
5.3	Bending.....	38
5.4	Buckling .....	40
5.5	Further research .....	42
6	REFERENCES.....	45
	APPENDIX A – PAPER I.....	53
	APPENDIX B –PAPER II.....	79
	APPENDIX C – PAPER III.....	107
	APPENDIX D – PAPER IV .....	131
	APPENDIX E – PAPER V .....	153
	APPENDIX F - GLOSSARY .....	175





## 1 INTRODUCTION

Since the first structures were formed, whether by nature or early human beings, they have been plagued by deterioration and destruction. Deterioration and destruction are laws of nature that affect even the most modern of structures. Modern structures, like skyscrapers and bridges are costly to build and the construction period may sometimes be disturbing to people and society. Therefore it is of interest to have durable structures with long life and low maintenance costs. Maintenance is not only about costs but also a necessity to keep a structure at a defined performance level. The definition of performance includes load carrying capacity, durability, function and aesthetic appearance. A structure that fulfils all demands of load carrying capacities might at the same time not satisfy durability demands or please the society's demands for aesthetic appearance. Absence of, or incorrect maintenance will in most cases increase the speed of the degradation process and therefore lower the performance of the structure. If the performance level has become too low, then repair is needed to restore the structure to its original performance. Structures with long lifespan, which most of the civil and building structures should have, will meet changed demands placed on them from the owners, users or surrounding society. A structure with satisfactory load bearing capacity, aesthetic appearance, and durability might not fulfil the function demands. A bridge can for instance be too narrow. To meet changed demands, a structure may be upgraded, which furthermore can be a way to increase life, durability and reliability of the structure.

### 1.1 Background and problem identification

The society around us is changing and so are the demands on existing structures. Transportation has become heavier and more frequent during the last decades and will probably continue that way in the future. The vehicle speed has increased which also leads to higher loads by dynamic effects. The knowledge in structural behaviour has increased and sometimes led to awareness of unreliable structures. Structures are sometimes damaged by accidents. Ships, cars or for example trucks can collide with bridges and the structure may be damaged. Sometimes structures are insufficient to

carry loads either due to incorrect design or mistakes during construction. Furthermore reasons for repair or upgrading may be widening of bridges or problems initiated by temporary overload. If the performance level of a structure becomes inadequate, for example by one of the above reasons, it might be possible to keep it in service with restrictions of use. Otherwise, the structure has to be upgraded or replaced. One way to upgrade, mainly for higher load bearing capacity but also for other performance levels, is strengthening.

All of the above aspects present a demand for strengthening, also often called retrofitting. The number of bridges in deficient condition varies according to the literature. For the USA the number is roughly about 30 % of nearly 600 000 bridges, (Xanthakos, 1996; Mallet, 1994; and Norris et al., 1997). For the rest of the industrial countries the situation is more or less the same. Put in economic terms, the magnitude of our infrastructure maintenance needs is enormous. Worldwide about 10 % of GDP is derived from infrastructure construction. In USA alone, there are approximately \$ 17 trillion worth of infrastructure in place, (Li, 1998). In every case it should be determined whether it is more economical to strengthen the existing structure or to replace it. With environmental and economical aspects in mind it is untenable to replace all structures. In many cases it is advantageous to take action on the existing structure instead of erecting a new one. Existing structures have an intended lifespan and are supposed to fulfil a certain function during that time. Strengthening can make it possible to prolong this period. Instead of replacing a structure, the lifespan should be extended to an optimum. This may be reached by an administrative upgrading where refined calculation models are used in connection with higher exactness for material parameters to show that the existing structure has a higher load-carrying capacity than what was earlier assumed. This can also in some cases be used to show that the structure can fulfil new demands.

If strengthening is needed there exist a variety of methods, for example adding on new structural material, post-tension cables, or changing the structural system (Carolin, 1999). These methods have been proven to work well in many situations. However, they may, in some cases have drawbacks that make the method too expensive to use or not as effective as wanted in terms of time and structural behaviour. Due to the different advantages and drawbacks of strengthening methods, designers must closely evaluate all alternatives including the possibility that upgrading may not be the best choice and replacement is the alternative. During the last decade, it has become more and more customary to strengthen concrete structures by bonding advanced composite materials to their surfaces. The method involves a material with high tensile strength and relatively high stiffness being bonded to the surface of a structural element to serve as additional reinforcement (Shin and Lee, 2003). The most common material used is carbon fibre fabric or laminate. In the future it will probably be even more common with strengthening as new methods are developed and as the knowledge on environmental aspects and life cycle cost increase.



### **1.1.1 Aims**

The overarching aims of the present thesis are to investigate composite materials for the purpose of strengthening structures and to improve the understanding regarding such strengthening operations. This general goal is divided into six more distinct aims.

Firstly, the thesis aims to investigate aspects of strengthening of existing structures.

Secondly, the thesis aims to clarify possibilities and drawbacks when strengthening structures with composites.

Thirdly, the thesis aims to give an idea towards design of strengthening with composites for increased shear bearing capacity.

Fourthly, the thesis aims to investigate the method for strengthening with composites in flexure. An improved method is investigated, where the composite is placed in sawn grooves. This method is called Near Surface Mounted Reinforcement, NSMR.

Fifthly, the thesis aims to investigate whether composites may be used for strengthening for increased buckling load of steel members.

Finally, the thesis aims to find and distinguish valuable subjects for further research.

### **1.1.2 Limitations**

All structures deteriorate, regardless of material, and might need strengthening. The thesis covers mainly strengthening of concrete structures but one application regarding strengthening of steel structures is also studied. Within composite strengthening many different variations of strengthening exist, but in this thesis only strengthening with non pre-stressed composites will be studied. Furthermore, with one exception only carbon fibre composites are studied.

## **1.2 Description of thesis content**

In order to get an overview of this thesis the following chapters are listed below with a short description of the content.

In Chapter 2, different aspects of strengthening of existing structures are presented.

In Chapter 3, fibre reinforced polymers (FRP) are presented in general. The most common FRPs are studied but the focus is on carbon fibre reinforced polymers. This chapter also includes theories for mechanical properties of anisotropic materials.

In Chapter 4, the method of plate bonding is presented with a description of the strengthening application process and examples of undertaken projects.

In Chapter 5, appended papers are summarised. The research significance of each topic is presented. In this chapter conclusions are drawn and suggestions are given for further research.

In Chapter 6, references are given for all cited literature. In the text are sources cited within brackets. However, when an author is referred to within a sentence, only the year is in brackets. Some reference source citations are followed by “Appendix #” (where # is an letter) which means that the full reference information is found in the reference list and that the reference also is appended to this thesis as Appendix #.

Appendix A consists of a paper manuscript titled “Experimental study on strengthening for increased shear bearing capacity” by Anders Carolin and Björn Täljsten, submitted to *Journal of Composites for Construction*. Anders Carolin’s contribution to the paper is planning large parts of the tests, performing and participating in the tests, evaluating data and finally writing the paper including drawing the figures.

Appendix B consists of a paper manuscript titled “Theoretical study on strengthening for increased shear bearing capacity” by Anders Carolin and Björn Täljsten, submitted to *Journal of Composites for Construction*. Anders Carolin’s contribution to the paper is the literature review, derivation of proposed model, comparison with tests, and finally writing the paper including drawing the figures.

Appendix C consists of a paper titled “Concrete structures strengthened with Near Surface Mounted Reinforcement of CFRP” by Björn Täljsten, Anders Carolin and Håkan Nordin, accepted for publication in *Advances in Structural Engineering - An International Journal*. Anders Carolin’s contribution to the paper is the part on non prestressed strengthening. This includes planning large parts of the tests, participating in the tests, evaluating data and finally writing parts of the text for the paper.

Appendix D consists of a paper manuscript titled “Concrete Beams exposed to Live Loading during CFRP Strengthening” by Anders Carolin, Björn Täljsten and Arvid Hejll, submitted to *Journal of Composites for Construction*. Anders Carolin’s contribution to the paper is literature review, planning large parts of the tests, participating in the test and finally writing the paper including drawing the figures.

Appendix E, consists of a paper manuscript titled “Stability improvement of axially loaded steel members by CFRP strengthening” by Anders Carolin, Björn Täljsten and Lars Åström submitted to *Steel & Composite Structures – An international Journal*. Anders Carolin’s contribution to the paper is planning large parts of the tests, performing and participating in the test, evaluating data, derivation of proposed models, comparison, and finally writing the paper including drawing the figures.

In Appendix F, a glossary is presented of phrases, acronyms and abbreviations concerning the studied area.

## 2 STRENGTHENING

### 2.1 Challenges

For an uninitiated person an upgrade might be considered to be a small and simple alteration of an existing structure. However, it is often more complicated to strengthen an existing structure than erecting a new one. Concerns must be taken to existing materials, often in deteriorated condition, loads during strengthening and to existing geometry. In some cases it can also be difficult to reach the areas that need to be strengthened.

When strengthening is going to be undertaken all failure modes must be evaluated. Strengthening a structure for flexure may lead to a shear failure instead of giving the desired increased load bearing capacity. It should also be noted that not only the failure mode of the strengthened member is important. If a critical member in a structure is strengthened, another member can become the critical one. Because of changed stiffness in an undetermined structural system the whole structure must be investigated. The strengthening should also be designed with consideration to minimise the maintenance and repair needs. When a strengthening is designed, the consequences from loss of strengthening effectiveness by fire, vandalism, collision, etc. must in addition be considered, (Chaallal et al, 1998a).

Furthermore, the existing documentation of the structure is often very poor and sometimes even wrong. It might be necessary to redesign the structure with the probable former codes that were active when the structure was built. This can give enough knowledge about the structural mode of action, otherwise field investigations must be undertaken to provide an understanding of the structure. The design of a strengthening however must fulfil requirements in the codes of today.

It is not only the financial and structural aspects that should form the basis for decisions of strengthening and choice of strengthening method, but environmental and aesthetic aspects must also be considered, (Carolin, 1999).

## 2.2 Ductility

Most fibre composites are, as will be described in the next chapter, linear-elastic material without any defined yield plateau. Structures, on the other hand, should be designed to fail in a ductile way or at least with adequate warning signals preceding a potential collapse. Ductility can be defined as the capability of a structure to deform while still carrying the load even when the maximum load bearing capacity is exceeded. It is important to distinguish between material ductility and structural ductility, (Gabrielsson, 1999). Steel bars with short anchorage can be an example of brittle failures even though steel is considered to be a ductile material. As will be shown in the following, material properties and structure ductility are not directly dependent, and linear-elastic materials may increase the ductility of a structure.

A concrete beam reinforced in bending with steel bars is often considered to have a very ductile behaviour. However, consider the same beam subjected to a fatigue load that causes high strains in the steel both in compression and in tension. The loading will make the structure to fail in a brittle way, but even worse the normal behaviour of the structure will lull a lot of people into a false security of a ductile behaviour. Consider the same beam again, with the fatigue load, but this time strengthened with a linear elastic material. Now the strengthening will decrease the stresses in the steel and the steel rebars will not fail in fatigue, instead the ductile behaviour is regranted.

Work has been carried out on many different types of structures to restore or increase the flexural capacity, which gives that the structure will be loaded closer to its maximum shear capacity. Täljsten (1994) even shows in a full-scale test that a flexural strengthening can induce a shear failure. One of the chief concerns is that shear failures are often very brittle with no, or only small warnings preceding the failure. Structures strengthened in shear often have, if it fails in shear, a more brittle failure because of the higher elastic energy built up compared to what it had before strengthening. On the other hand, a structure with a brittle failure in shear may be strengthened so that the failure mode will change to a more ductile and friendly mode, (Carolin and Täljsten, 2003a, Appendix A).

## 2.3 Strategies for strengthening

When a structure is going to be strengthened there are several aspects to consider. In Figure 2-1 some of the reasons for strengthening from Chapter 1 are presented. The example in Figure 2-1 shows a schematic example of a structure that had inadequate load bearing capacity due to a design fault already present before it was taken into service. It was then strengthened slightly above the desired performance level. After some time the structure was damaged due to an accident, collision, fire or overload that damaged the structure to a level where performance requirements were not fulfilled. The damages were then repaired to a new satisfactory performance level. Later, the demands on the structure were changed, higher load bearing capacity was required, and the structure needed to be strengthened to a higher performance level to

meet these demands. By a third strengthening it was possible to meet the new demands and keep the structure in service.

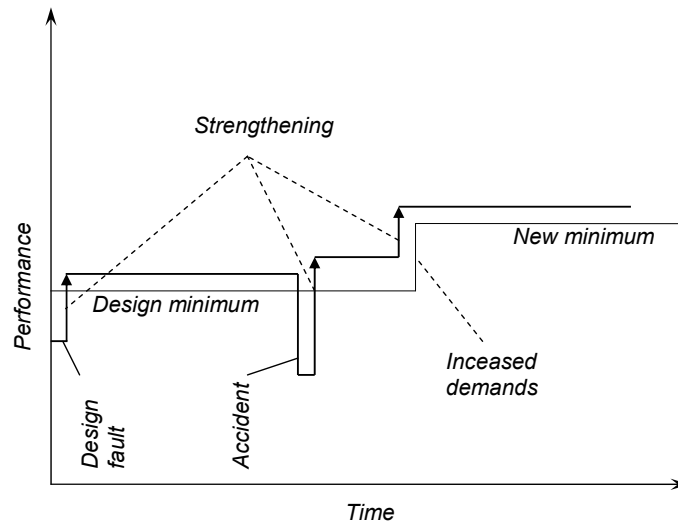

Figure 2-1: Performance history of a structure

Without considering deterioration the need for strengthening may not be that complicated. Insufficient performance due to a design fault, accident, or increased demands can quite clearly be identified. When deterioration is significantly prevalent it becomes more complicated. For a new structure that is inadequate due to a design or constructional fault, the size of the problem is more or less well-known and the desired life of the structure can also be quite clearly expressed. The selection of suitable strengthening methods can nevertheless be complicated. For older structures in need of strengthening, the situation becomes even more complex. One important issue is the remaining life of the structure. It is not always valid to strengthen a structural part to give it 50 years remaining life if the foundations, for instance, will only function for another 10 years. For example a road network may be changed within 5 years due to a larger infrastructure project. If a bridge on the existing road needs to be repaired to provide satisfactory reliability in the meantime, it would be very cost ineffective to replace the old bridge with a new. In this case the bridge, if possible, should be repaired and the repaired bridge does not need to have a lifespan longer than 5 years.

With deterioration in mind the strategy for strengthening becomes more complicated. This is schematically illustrated in Figure 2-2. The performance level of a structure is slowly decreasing, but it still fulfils its performance requirements. New demands are placed on the structure, but for the time being it still fulfils the performance requirements. The decrease of performance will in the nearby future result in structure being inadequate, marked by X. The rate of degradation can be

different in different cases but that is not discussed any further in this thesis. However, the structure must be upgraded, in this case by strengthening.

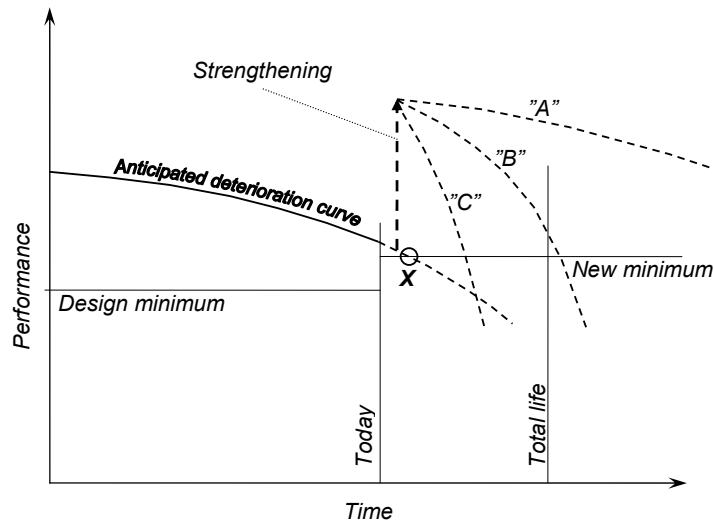

Figure 2-2: Deterioration and strategies for strengthening

First it must be decided to what level the upgrading shall increase the performance of the structure. Secondly, the most suitable method must be chosen for upgrading. Method "A" is a very good method, but in this case method "B" is more cost effective and should be used. Method "C" does initially increase the performance of the structure. However, in this case method "C" was a poor method and it increases the deterioration process of the structure to a level that the performance within the desired life actually becomes lower compared to the original non-strengthened structure.

#### 2.4 Partial coefficients

Many codes, for example the Swedish BKR94 (1994) and Eurocode (1991), are based upon reliability and partial coefficients. Both bearing capacity of the structure and the load effect have statistical distributions, as illustrated in Figure 2-3. Failure occurs when the load effect,  $S$  (from French: *Sollicitation*), are higher than the bearing capacity,  $R$  (from French: *Résistance*). In the example, failure will not occur if the load bearing capacity is one of the 1 % lowest cases and if the load effect is just normal. Failure will occur when the load effect has one of the highest values and load bearing capacity has one of the lowest values at the same time.

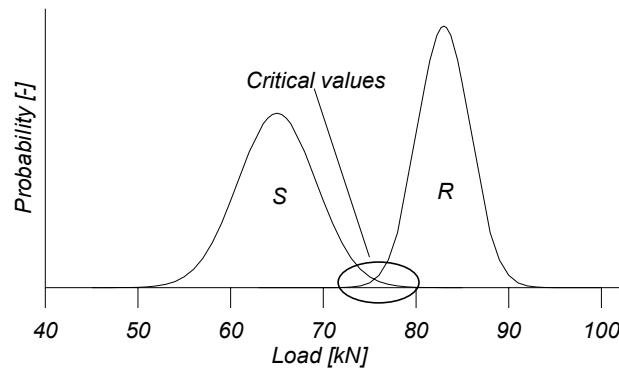

Figure 2-3: Statistical distribution of load effect and load bearing capacity.

In normal design by Swedish BKR94 (1994), the lower 5 %-fractal is used as characteristic values  $f_k$  of the materials. These values are then reduced by partial coefficients  $\eta\gamma_n$  and  $\gamma_m$  as presented in Eq. 2-1 and the bearing capacity can then be estimated from the calculated parameters,  $f_d$ .

$$f_d = \frac{f_k}{\eta\gamma_n\gamma_m} \quad (2-1)$$

The load effect is taken as a statistical upper limit. Depending on safety class (1, 2 or 3) this will give a yearly risk of failure of  $10^{-4}$  -  $10^{-6}$ .

#### 2.4.1 Load effect

The load effect depends on many stochastic variables, wind, dynamic load effects, snow, etc. In the case of strengthening, in some cases it can be possible to determine the future load effect more precisely compared to the design of a new structure. It can actually be possible to measure the load effect on a structural member when a load is applied on the structure. Dead-load can be estimated better when the true dimensions can be measured. Loads from support settlements can in some cases be reduced when an old structure is going to be strengthened. This can make the scatter of the load effect narrower. Strengthening with plate bonding with CFRP does not significantly change a structure's dead-load. The load effect on a member in a statically undetermined system can still be altered because of changed stiffness of the studied member. The load effect will, however, not be further discussed here.

#### 2.4.2 Load bearing capacity

For a reinforced concrete structure, several stochastic variables affect the load bearing capacity. Concrete capacity, steel reinforcement properties, length of internal lever arm, mode of failure and anchorage of reinforcement are all important variables for a structure subjected to flexure. If the same structure is strengthened with externally bonded CFRP then new variables, composite properties and new failure modes for

instance, may be added. On the other hand, when a structure is going to be strengthened it is possible to undertake field measurements that can give a more determined description of the existing materials, dimensions and possible defects of the structure. When strengthening is applied the length of the internal lever arm for the composite might be deterministic.

The load bearing capacity for a strengthened structure will be dependent on more factors compared to the load capacity of the original structure. The mode of failure will change depending on how much the structure is strengthened. However, to a certain amount the failure mode can be quite reliably described. A normal reinforced concrete member that “fails” by yielding of reinforcement will for a small amount of strengthening fail by fibre rupture, on the assumption that anchorage is sufficient. For structures heavily strengthened, the mode of failure will most likely change to concrete crushing.

### **2.4.3 Risk of failure**

Reliability studies on load bearing capacity for strengthened concrete structures have been presented by Plevris et al. (1995) and Monti and Santini (2002). The risk of failure is expressed by the probability of load effect becoming larger than load bearing capacity. The level of load effect might change due to strengthening but the distribution will be less likely to change. Therefore, in the following limited discussion the load effect will be considered deterministic and only the distribution of the bearing capacity affects the risk of failure.

Consider two different concrete beams subjected to bending. The first one is an over-reinforced beam critical in crushing of concrete. However, a beam like this can be strengthened by adding tensile reinforcement since that will increase the size of the compression zone. The second beam is a normal reinforced beam and therefore limited by yielding of steel. The concrete quality and capacity is much higher than assumed in design phase, and this results in the possibility for the beam to be strengthened more than desired by adding tensile reinforcement. For both cases the strengthening will not change the failure mode, which makes the following discussion easier, where the second case will be the base.

For an under reinforced beam the bearing capacity is mainly limited by the amount of reinforcement, and in case of a strengthened beam, reinforcement consists of both internal steel bars and CFRP strengthening. The ultimate capacities of the two materials as well as the two different internal lever arms are independently stochastic. For failure, it is necessary that all variables are at a critical value at the same time. A weak steel bar can be compensated by the composite having its mean value and the structure will have a bearing capacity larger than the load effect. In the same way, a steel bar with medium performance can compensate for a composite that has a performance lower than its 5 % -fractal. The risk for both materials and therefore the load bearing capacity to be lower than the minimum acceptable level for the strengthened structure will decrease compared to the non-strengthened structure. It would be possible to choose partial coefficients so that the risk for failure will be the



same for the original structure subjected to original loading and the strengthened structure with the new loading conditions. Since different amounts of strengthening will give different importance to the different stochastic variables it would imply that the partial coefficient will vary with the strengthening amount. This is not reasonable and it is suggested that the additional reliability of the structure instead is seen as an extra security provided by the strengthening system. The partial coefficient should be determined as if the variables for the existing structure are deterministic.



## 3 FIBRE REINFORCED POLYMERS

Fibre reinforced polymers, FRP, are what many people refer to as composites. The word composite comes from the Latin word *componere*, which means put together. A composite is a material formed from two or more separate parts with a distinguished phase between them. Consequently, there are plenty of composites around us. Composite will in the following refer to fibre reinforced polymers. This is a composite where a polymer matrix is reinforced with many relatively thin and long fibres. These composites are to be found in sports equipment, aircraft, and the spacecraft industry. Although composites have been used for some time in the building industry, the usage and the material itself can be considered as new within building industry perspectives.

### 3.1 Composite components

#### 3.1.1 Fibres

The composite's properties are mainly influenced by the choice of fibres. In civil engineering three types of fibres dominate. These are carbon, glass, and aramid fibres and the composite is often named by the reinforcing fibre, e.g. CFRP for Carbon Fibre Reinforced Polymer. They have different properties, including price, which make one more suitable than the other for different purposes. For strengthening purposes carbon fibres are the most suitable and will therefore be focused on in the following. All fibres have generally higher stress capacity than ordinary steel and are linear elastic until failure. The most important properties that differ between the fibre types are stiffness and tensile strain. The three fibre types are schematically presented in Figure 3-1 in comparison with an ordinary steel bar and a steel tendon. In Table 3-1 some material data for the most common materials is presented. Further information about materials can be found in *Betonghandboken* (1994), Hedin and Lundin (1993) and Hull and Clyne (1996).

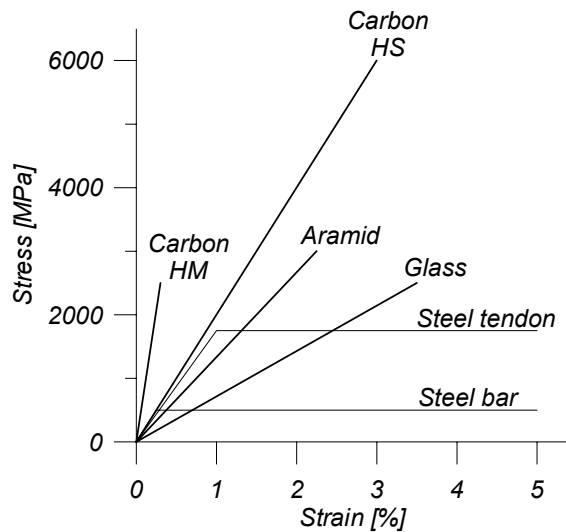

Figure 3-1: Properties of different fibres and typical reinforcing steel. After ACI Committé 440 (1996) and Dejke (2001).

Table 3-1 Mechanical properties of common strengthening material

Material	Modulus of elasticity [GPa]	Compressive strength [MPa]	Tensile strength [MPa]	Density [kg/m <sup>3</sup> ]
Concrete	20-40	5-60	1-3	2400
Steel	200-210	240-690	240-690	7800
Carbon fibre *	200-800	NA **	2500-6000	1750-1950

\*) Given values are for plain carbon fibre. The characteristics of the composite will vary with amount and property of the used matrix.

\*\*) Not applicable. Plain fibres buckle.

### Carbon

Carbon fibres have a high modulus of elasticity, 200 – 800 GPa. The ultimate elongation is 0.3 – 2.5 % where the lower elongation corresponds to the higher stiffness and vice versa. Carbon fibres do not absorb water and are resistant to many chemical solutions. They withstand fatigue excellently, do not stress corrode and do not show any creep or relaxation, having less relaxation compared to low relaxation high tensile prestressing steel strands. Carbon fibre is electrically conductive and, therefore, might give galvanic corrosion in direct contact with steel.

### Glass

Glass fibres are considerably cheaper than carbon fibres and aramid fibres. Therefore glass fibre composites have become popular in many applications, the boat industry

for instance. The moduli of the fibres are 70 – 85 GPa with ultimate elongation of 2 – 5 % depending on quality. Glass fibres are sensitive to stress corrosion at high stress levels and may have problems with relaxation. Glass fibres are sensitive to moisture, but with the correct choice of matrix the fibres are protected.

### **Aramid**

Aramid is short for aromatic polyamid. A well-known trademark of aramid fibres is Kevlar but there exist other brands too, e.g. Twaron, Technora, and SVM. The moduli of the fibres are 70 – 200 GPa with ultimate elongation of 1.5 – 5 % depending on quality. Aramid has a high fracture energy and is therefore used for helmets and bullet-proof garments. Aramid fibres are sensitive to elevated temperatures, moisture and ultra violet radiation and are therefore not widely used in civil engineering applications. Further, aramid fibres do have problems with relaxation and stress corrosion.

#### **3.1.2 Matrices**

The matrix should transfer forces between the fibres and protect the fibres from the environment. In civil engineering, thermosetting resins (thermosets) are almost exclusively used. Of the thermosets vinylester and epoxy are the most common matrices. Epoxy is mostly favoured above vinylester but is also more costly. Epoxy has a pot life around 30 minutes at 20 °C but can be changed with different formulations. The curing goes faster with increased temperature. Material properties for polyester and epoxy are shown in Table 3-2. Epoxies have good strength, bond, creep properties, and chemical resistance.

*Table 3-2: Properties for matrix materials.*

Material	Density [kg/m <sup>3</sup> ]	Tensile strength [MPa]	Tensile modulus [GPa]	Failure strain [%]
Polyester	1000-1450	20-100	2,1-4,1	1,0-6,5
Epoxy	1100-1300	55-130	2,5-4,1	1,5-9,0

### **3.2 Composites**

When the fibre and the matrix are combined into a new material it becomes a composite. The fibres may be placed in one direction in the composites and then the composite is unidirectional. However, fibres may also be woven or bonded in many directions and the composite becomes bi or multi directional. For strengthening purposes it is most common to use unidirectional composites and those will be studied in the following. The manufacturing of composites can be made by a number of different methods: hand lay-up, pultrusion, filament winding, and moulding. The composites mechanical properties are dependent on the fibres, matrix, fibre amount,

and fibre direction. Also the volume or size of the composite will affect the mechanical properties. The fibre content by volume,  $V_f$ , is normally 30 – 60 %, depending on materials, manufacturing process, and desired properties. Fibre content is defined by Equation (3-1).

$$V_f = \frac{v_f}{v_c} \quad (3-1)$$

where  $v_f$  and  $v_c$  are the volume of fibres and the volume of composite respectively. CFRP has a thermal coefficient (in fibre direction) around  $1 \cdot 10^{-6} \text{ K}^{-1}$ . The thermal coefficient for reinforced concrete is normally assumed to be  $10 \cdot 10^{-6} \text{ K}^{-1}$ .

### 3.2.1 Mechanical properties

The stiffness of a composite in fibre direction  $E_L$  can roughly be determined by taking the fibre content multiplied by the stiffness of the fibres in its longitudinal direction. A more precise value can be calculated by the “*rule of mixture*”, Equation (3-2).

$$E_L = E_f V_f + E_m V_m \quad (3-2)$$

where index  $f$  is used for fibre and  $m$  for matrix. Different fibres may be mixed, so that the composite obtains yield behaviour when loaded. Apinis et al. (1998) developed ductile composites by mixing carbon and aramid and carbon and glass. The composite was designed so that stiff carbon fibre ruptured at onset of “yielding”. The remaining fibres, glass or aramid, carried alone a load 10 % higher than the load when carbon ruptured. The used fibres, aramid or glass, had lower stiffness than the carbon and the ultimate load was reached after rather large deformations. These kinds of composites are called hybrid composites but have not been broadly used for strengthening. Apinis et al. (1998) also developed a rod with yield behaviour by braiding rods with an open core that collapsed at a certain load and thereby reduced the stiffness.

When the contribution from the strengthening is going to be calculated it is important to consider the anisotropic behaviour of the composite material. The composites have their high strength and high stiffness in the fibre direction and are weak in the perpendicular direction. Since the material is highly anisotropic the consequences can be devastating if the material is placed in the wrong direction. When plate bonding is used for flexural strengthening the direction of the principal stresses are often easy to predict and the fibres can be placed in the most effective direction. When it comes to shear the principal strains and stresses will just in exceptional cases coincide with the fibre direction. It is therefore necessary to understand how the composite will behave when it is loaded by shear or tensioning in a direction other than that of the fibres. Stresses can be transformed the angle  $\theta$  from one direction to the other using the following relationship, (Agarwal and Broutman, 1990), where

$L$  and  $T$  are subscripts for the fibres longitudinal and transverse axes respectively.  $x$  and  $y$  are arbitrary perpendicular axes.

$$\begin{Bmatrix} \sigma_L \\ \sigma_T \\ \sigma_{LT} \end{Bmatrix} = [T] \begin{Bmatrix} \sigma_x \\ \sigma_y \\ \sigma_{xy} \end{Bmatrix} \quad (3-3)$$

where  $[T]$  is the transformation matrix which equals

$$\begin{bmatrix} m^2 & n^2 & 2mn \\ n^2 & m^2 & -2mn \\ -mn & mn & m^2 - n^2 \end{bmatrix} \quad (3-4)$$

with  $m = \cos(\theta)$  and  $n = \sin(\theta)$ . For the strains the following relation is valid;

$$\begin{Bmatrix} \varepsilon_L \\ \varepsilon_T \\ \gamma_{LT} \end{Bmatrix} = ([T]^{-1})^T \begin{Bmatrix} \varepsilon_x \\ \varepsilon_y \\ \gamma_{xy} \end{Bmatrix} \quad (3-5)$$

Compared to Hook's law for isotropic materials the stress-strain relationship becomes more complicated for composites. The following relationship is valid for transforming principal strains into principal stresses:

$$\{\sigma\} = [Q]\{\varepsilon\} \quad (3-6)$$

where  $[Q]$  is the matrix of stiffness and consists of:

$$Q_{11} = \frac{E_1}{1 - \nu_{12}\nu_{21}}, \quad Q_{12} = Q_{21} = \frac{\nu_{12}E_2}{1 - \nu_{12}\nu_{21}}, \quad Q_{22} = \frac{E_2}{1 - \nu_{12}\nu_{21}}, \quad \text{and} \quad Q_{33} = G_{12}$$

For transforming stresses into strains the relationship becomes

$$\{\varepsilon\} = [S]\{\sigma\} \quad (3-7)$$

$$\text{where } S_{11} = \frac{1}{E_1}, \quad S_{12} = -\frac{\nu_{21}}{E_2}, \quad S_{21} = \frac{\nu_{12}}{E_1}, \quad S_{22} = \frac{1}{E_2}, \quad \text{and} \quad S_{33} = \frac{1}{G_{12}}$$

All the needed properties can be found from tensile tests. Specimens need to be tested in the fibres' axial direction, transverse direction and in an off-axis direction.

### 3.2.2 Durability

Carbon fibre polymers are very durable in most aspects. One of the biggest advantages is that the composite does not corrode. The durability problems that can be identified are mostly connected to the matrix. Epoxy is a good polymer that withstands deterioration fairly well in most aspects. Epoxy does not absorb water significantly contrary to other polymers. However, the matrix may be damaged by ultra violet radiation. With special additives the epoxy can also withstand UV. If the composite is painted, satisfactory protection is also achieved. The matrix may also be sensitive to elevated temperatures. If there is a risk for fire the composite should be protected by special arrangements. Plate bonding with composites withstand fire a longer time than plate bonding with steel plates due to the lower thermal conductivity of the composite.

If the pure carbon fibres come in contact with steel there may be a risk for galvanic corrosion. As long as the matrix is intact there are no problems with contact between the composite and steel. It is also possible to bond a thin isolating layer of glass fibres to the steel before the carbon fibres are applied. The electrical conductivity also gives a theoretical risk of being destroyed by lightning. This is not a probable event since a strengthening system is never earthed. This type of “deterioration” has furthermore never been reported.

More issues and deeper studies regarding durability for composites can be found in (Dejke, 2001 and Benmokrane and Rahman, 1998). Durability is not only an issue for the bonded material. When adding a material to a structure, the deterioration process of the structure may change which may become more important than the deterioration of the bonded material. This is further discussed in Chapter 5.

### 3.3 Environmental aspects

All materials can be harmful to man if used in the wrong way or for the wrong purpose. This is certain for washing detergent and other chemical products that are used daily, although in those cases there is a good knowledge of how the materials should be handled, (Augustsson, 1995). Epoxy is a thermosetting plastic that consists of two parts, a resin and a hardener. The fully cured product involves no environmental or health problems and can be found around us every day. On the other hand if the two compounds are improperly handled they can cause allergy and irritations. Epoxy has to be handled with care and the right protective equipment with respect to the nature of the work should always be used. For example work above the head should always be done with a face protection as a complement to protection gloves and disposal overall. A special restricted station should be used for mixing and cleaning of the equipment when the work is done in the field. If the advice from supplier and the labour welfare act are followed there are no problems with epoxy or the components.



## 4 PLATE BONDING

As Described in chapter 2, structures often need to be repaired or strengthened and there exist a variety of methods. In this chapter plate bonding, a method that may be used for repair and strengthening (Labossière et al., 2000) will be studied. The idea of plate bonding is mainly based on the fact that concrete is a building material with high compressive strength and poor tensile strength. A concrete structure without any form of reinforcement subjected to tension or bending will crack and fail at a relatively small load. Concrete's compressive strength increases in most cases over time due to maturing, (Rådman, 1998 and Thun, 2001). Unfortunately, the tensile strength does not increase in the same way over time. This means that concrete structures' load bearing capacity is often limited by the amount of reinforcement. By adding reinforcement by bonding it to the surface the load bearing capacity may in many cases be increased. Nowadays, the bonded plate is mostly a sheet or laminate of fibre reinforced polymer (Bencardino et al., 2002), but that has not always been the case as will be discussed below.

### 4.1 Steel plate bonding

Steel plate bonding has its origin in South Africa in the mid 60s where a concrete beam in a real estate building needed to be strengthened due to a mistake in the construction stage. Some of the steel reinforcement had been omitted. Steel plate bonding was used to solve the problem, (Dussek, 1974). During the mid 70s extensive research was carried out in the field of steel plate bonding (Täljsten, 1994). Since then, the method has been used all over the world; France, (L'Hermite, 1967 and Bresson 1971), Israel; (Lerchental, 1967), Switzerland; (Ladner and Flueler, 1974), Japan; (Raithby, 1980), United Kingdom; (Swamy and Jones, 1980), Australia; (Palmer, 1979), Sweden; (Täljsten, 1990), Poland; (Jasienko and Leszczynski, 1990) and the United States; (Klaiber et. al., 1987 and Iyer et al., 1989). Even if this method technically performs quite well it has some drawbacks. One is that the steel plates are often heavy to mount at the work site. If the bonding is done upside down it is necessary with external pressure during the curing of the adhesive. Another drawback

is the risk of corrosion of the steel plates used. A third is that steel plates might need lengthening by joints due to limited transportation length. Furthermore, steel plates may be difficult to apply to curved surfaces.

## **4.2 FRP Plate bonding**

### **4.2.1 Introduction**

For plate bonding, steel has in most cases been driven out of competition by composites. CFRP, as discussed in Chapter 3, does not corrode, can come in any length, and has high stiffness to weight ratio. Although the weight aspect is not as critical in bridges as it is in other industries, weight reduction is a benefit during the work at a construction site, (Xanthakos, 1996). Low weight makes it easier to handle the material on the site and it doesn't change the frequency of the original structure. In addition, composites are formable and can be shaped to any desired form. During the last decade FRP plate bonding has developed into an accepted method all over the world, (Täljsten, 1994, 2000; Gemert, 1996; Okorowski et al, 1996; Burgoyne, 1999; Erki, 1999; Fukuyama, 1999; Karbhari and Seible, 1999; Meier, 1999 and Alkhrdaji et al., 2002). Most of the research and therefore also most of the undertaken projects have been done for flexural strengthening, (Shin and Lee, 2003 and Breña et al., 2003) and column wrapping, (Seible et al., 1997; Thériault, 2002 and Chaallal et al., 2003). The method is also very effective in increasing shear capacity of structural members, (Shehata et al., 1996; Täljsten, 1996, 1997; Pellegrino and Modena 2002; Micelli 2002; Diagana et al., 2003 and Carolin and Täljsten, 2003a, 2003b, Appendix A and B). In this case the bonded plates become external stirrups. Torsional strengthening of structural members using FRP has also been studied, even though in a much smaller extension, (Ghobarah, 2002). Grace et al. (2002) have undertaken tests with hybrid composites and showed that these composites may give strengthened beams similar flexural response as steel reinforced beams. The strengthening method has become increasingly popular in recent years, (Levar and Hamilton, 2003). The method of strengthening by use of carbon fibres is described by Lane et al (1998), as a groundbreaking structural repair technique. Alexander and Cheng (1996) conclude that the method is very competitive; both from a practical and economical point of view and that the cost for the method will probably decrease further as the method becomes more common and the knowledge increases.

FRP plate bonding can be divided into three types; laminate plate bonding, hand-lay up method, and Near Surface Mounted Reinforcement, NSMR. The laminate plate bonding implies that a premanufactured, often pultruded, composite laminate is bonded to the surface of a concrete structure. The hand lay-up method, is characterised by dry fibres and matrix that are systematically applied to a surface and the composite is built up and bonded at that moment. Wiberg (2000) has investigated whether a cementitious mixture may be used as a matrix for hand lay-up, and concludes that this has a great potential but many questions have to be answered. For NSMR, grooves are cut in the concrete cover and composite rods are bonded in the groove. NSMR with quadratic CFRP rods has been developed at Luleå University of Technology starting

in the 90s, (Täljsten et al., 2003, Appendix C). NSMR may be bonded to the structure either by epoxy or grout. However this method also has its origin in adding steel reinforcement to an existing structure. In the 40s Asplund (1949) used grout to bond circular steel bars in grooves to a concrete bridge to compensate for misplaced steel reinforcement. For a further description of NSMR see Täljsten et al., 2003, Appendix C and De Lorenzis, 2002.

The strengthening processes for the three FRP plate bonding types are different in some aspects. However, roughly outlined they all involve three main moments: preparation, FRP bonding and completion.

#### 4.2.2 Preparation

Before a structure is to be strengthened there are certain steps that must be undertaken. The preparation will differ depending on the chosen type of strengthening, but some steps are common. If the inner reinforcement has extensive corrosion or if chlorides heavily contaminate the concrete, the corroded bars and the concrete should be removed and replaced to prevent the concrete cover spalling. When strengthening in the field, there can also be damages from vehicle impacts and from mistakes during construction that need to be considered. Figure 4-1 shows how minor holes and cavities have been repaired with putty and then being ground down.



*Figure 4-1: Grinding of putty repair of an old damage from vehicle impact*

The composites will carry high loads; therefore it is important that a good bond between the plate and the concrete is created. Laminate plate bonding and hand lay-up systems, both bonded to the structure's surface, require that the aggregates are uncovered so that the composite is bonded to a homogenous concrete unlike the outermost concrete layer from the time of casting. It is important that the concrete has a certain tensile strength to be able to transfer the shear stresses in the bond region. The needed tensile strength depends on the place of anchorage, material properties of

the plate and the adhesive. Many, like Täljsten (1994), Garden et al. (1998), Khalifa et al. (1999) and Tepfers (2000) have studied anchorage and transferring length. Considerations must also be given to peeling and delamination. For structural reasons there are demands of maximum roughness as well. The concrete surface must be even enough for the carbon fibre not to be bonded in a buckled or non-straight position. These two demands together imply that the surface must be sandblasted and sometimes ground before the strengthening work can commence. Laminate plate bonding can be used on a rougher surface. However, hand lay-up is suitable for curved surfaces, especially double curved. Demands for the evenness of the surface can be found in Täljsten, (2002). A belt sander, rotating grinder, sand blaster or water jet may be used to prepare the surface. For NSMR, the demands apply for the concrete cover instead of the surface. The concrete cover must be thick enough to make the grooves, which are made by a concrete saw. For all methods, compressed air or vacuum cleaning must be used to remove dust and debris from the surface or groove after sandblasting, grinding or sawing.

Most hand lay-up systems require that the concrete is treated with a primer prior to FRP bonding. The used bonding agent for hand lay-up, that also becomes matrix for the composite, must have low-viscosity properties to wet the fibres completely. The primer on the concrete prevents the epoxy from being absorbed by the concrete instead of wetting the fibres. The primer also penetrates the concrete via the pores and enhances the bond for the fibres, (Augustsson, 1995). Primer is also used for some laminate systems. Laminates however, are bonded to the surface with an adhesive with high viscosity. The primer is quickly and easily applied to the concrete with a soft roller, see Figure 4-2. The primer is not used by all strengthening systems and the recommendations from the manufacturer of each system should always be followed.



*Figure 4-2: Application of primer to the clean and smooth concrete surface.*

When NSMR rods are bonded with a cementitious bonding agent (as described in Carolin et al., 2003a, Appendix D) then the groove must be moisturised before the FRP bonding step.

#### 4.2.3 FRP bonding

After the preparation the strengthening system can be applied. For hand lay-up the strengthening work starts with applying adhesive to the prepared surface with a roller. Then the fibres are put in place. A roller is used to straighten the fibres and to remove all bigger voids. Normally there is a paper or plastic cover on the fibres to make the handling easier. If this is the case, the cover is removed before another layer of epoxy is applied. In the case where many layers are needed the last steps are repeated until desired thickness is achieved.

Laminate plate bonding starts with filling irregularities in the surface with putty, i.e. the high viscosity resin used for bonding the laminate. Epoxy is then applied to the laminate and the laminate is put in place. Pressure is applied to the laminate with a roller or by hand so that the epoxy is uniformly distributed. FRP bonding with hand lay-up is shown in Figure 4-3 and laminate plate bonding in Figure 4-4.



*Figure 4-3: Hand lay-up. The light colour shows paper to be removed, Täljsten and Carolin (1999)*



*Figure 4-4: Bonding of laminate*

For NSMR, the prepared groove is half-filled with adhesive and the quadratic rod is placed in the groove so the adhesive distributes uniformly around the rod and fills the groove.

Täljsten and Elfgrén (2000) have investigated different application methods for strengthening with carbon fibre sheets. They tested two hand lay-up systems, one pre-preg system and one system with vacuum-injection. Pre-preg systems are systems where the composite is impregnated with the adhesive but kept under specific

conditions, i.e. low temperature, that prevents it from curing. When the system is applied to a structure it is put under vacuum and heat so that the curing starts and the composite obtains a good bond to the surface. By vacuum-injection the fibres are placed on the structure with a bag covering the strengthening area. The resin is then forced by vacuum to infiltrate the composite from one end to the other by holes in the bag where the resin and the vacuum pump are connected. Täljsten and Elfgren (2000) found that the easiest way to apply the fibres was the hand lay-up method. This technique gave the lowest fibre content in the composite. However fibre content is not critical in plate bonding applications. The system of vacuum injection was the most environmentally friendly of the tested methods.

#### **4.2.4 Completion**

Completion work is mainly undertaken for durability and aesthetic reasons. To protect the matrix from UV-radiation the strengthening may be painted, which also may enhance the aesthetic performance. The colour can be chosen to camouflage the strengthening on the structure, camouflage the structure in its surroundings or to give a more colourful appearance in the environment. If there is a need to protect the composite from fire, special fibre protection should cover the strengthening. Other completion work might be due to surface requirements. Roughness can be arranged by spraying quartz sand onto the last uncured layer of epoxy from hand lay-up (Täljsten et al., 2000).

#### **4.2.5 Quality verification**

The success of a strengthening depends on good workmanship. There exist some measures that can be taken to minimise the risk for poor quality of the final strengthening. The quality of the concrete at the surface can be measured by pull-off testing. The evenness of the surface can be measured before the strengthening is applied. The reaction of the epoxy will not be satisfactory if the temperature is too low or if the relative humidity is too high. Both relative humidity in the air and in the concrete have certain critical levels that can be measured (Augustsson, 1995). The demands that must be fulfilled are:

- The relative humidity on the concrete surface must not be over 80 % at the time of application of primer, epoxy and paint.
- The temperature in the air must be at least 3 °C over actual dew point.
- Temperature in the air should not be below 10 °C.

However, the recommendations from reliable suppliers should always be followed. If the demands for curing are not fulfilled special arrangements are necessary. Tents and heating fans can be used to create the required environment.

After strengthening, once the adhesive has cured it is possible to detect voids underneath the fibres by tapping a coin on the fibre surface. The sound the tapping generates is different if voids are trapped compared to a good bond. Voids and debonding may also be detected by use of infrared thermography, (Levar and

Hamilton, 2003). By using heat sources and infrared cameras voids can be detected by the temperature differences between bonded and debonded areas that occur due to different heat transfer. Crack mapping should be undertaken so that cracks appearing after strengthening may be identified. In the event of cracks developing at the end of the fibres, these should be investigated. There is further limited destructive testing that can be undertaken on the composite to investigate the bond, i.e. torsional tests of the fibres bonded to concrete. The quality verification methods may be further studied in Täljsten, 2002.

#### **4.2.6 Advantages and disadvantages**

##### **Advantages**

The method may in some cases be used without any restrictions of the traffic on the bridge, (Täljsten and Carolin, 1999 and Carolin et al., 2003a, Appendix D). Further advantages are:

- A low weight of the fibres makes it easy to handle without lifting equipment at the site.
- Negligible changes of cross-section, self-weight, and free height of a structure.
- Quick to apply.

##### **Disadvantages**

There also exist disadvantages, such as:

- Without protection the reinforcement is fire and impact sensitive.
- Design consultants, contractors and clients have limited experience.

Depending on the structure going to be strengthened, different aspects might arise. For all strengthening methods it is of utmost importance to understand how the strengthening will affect the final structure. Not until then can it be decided whether plate bonding is a suitable method or not.

#### **4.3 Undertaken projects and full-scale tests**

Many researchers have shown that it is possible to strengthen structures with bonded composites. This has mostly been done in laboratories, often on scale-sized beams that are simply supported and loaded in three or four point bending. These idealised conditions are far away from the conditions prevailing for a real structure. Therefore it is important to carefully undertake field applications and full-scale tests. When a structure is changed, for example, by means of strengthening it is important to understand in which way the modification will affect the structure. In the following, four undertaken projects with CFRP strengthening will be presented.

### 4.3.1 The Kalkällan Bridge

Outside the centre of Luleå in the northern part of Sweden there is a railroad bridge called The Kalkällan Bridge, see Figure 4-5.



*Figure 4-5: The Kalkällan Bridge during winter season, (Täljsten and Carolin, 1999)*

The bridge is a three span trough bridge that was built in the sixties. The maximum allowed axle load has been increased from 25 tons up to 30 tons, (Banverket, 1996). Calculations made by the Swedish Road Administration for the higher axle load had shown that the bridge had a lack of bearing capacity across the bridge between the two main girders and that the bridge needed to be replaced, monitored or strengthened. However, except for the load bearing capacity the bridge was in fairly good condition. To investigate the method of plate bonding with CFRP, the Swedish Rail Administration decided to strengthen the bridge. Other strengthening methods were discussed as well but since the bridge is low with regard to the road underneath, those methods were considered not to be an alternative. When the strengthening method was chosen it was decided to keep the bridge in service during the strengthening process. In total 3200 m of carbon fibre sheets, 0.3 m wide, were used. In average the thickness of the composite was approximately 1.0 mm. The bridge was painted with a “concrete grey” polymer paint after the strengthening work was done. How the bridge was strengthened can be found in Figure 4-6. The project is further described in Täljsten and Carolin, 1999. The bridge was strengthened by a hand lay-up system from BPE® Systems with properties for the fibres as in Table 4-1.

*Table 4-1: Mechanical properties for the carbon fibres.*

Property	Suppliers data
Young's module [GPa]	234
Tensile strength [MPa]	4500
Ultimate tensile strain [%]	19



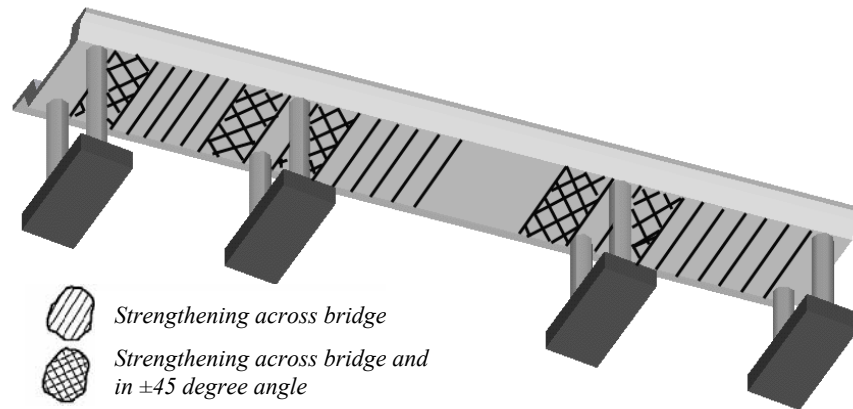

Figure 4-6: Strengthening scheme for the bridge

### Field measurements

To investigate whether the strengthening work gave the desired effect field measurements were undertaken. By measuring deformations and strains before and after strengthening it is possible to evaluate the strengthening effect. The measurements have been repeated two years and four years after the second measurement to investigate whether the effect remains or not. The loads, i.e. train weight, on the bridge have also been measured, and are essential for the evaluation of the strains and deformations. A system of steel beams was mounted on the top of the columns under the bridge. This was done to support the deformation gauges and minimise the interference from ground movement and column deformations. To ensure the measurements and to avoid resonance in the bridge itself, different train speeds were studied. The Strains have been recorded in the points indicated with arrows in Figure 4-7. The direction of the arrow indicates in which direction the measurements have been performed.

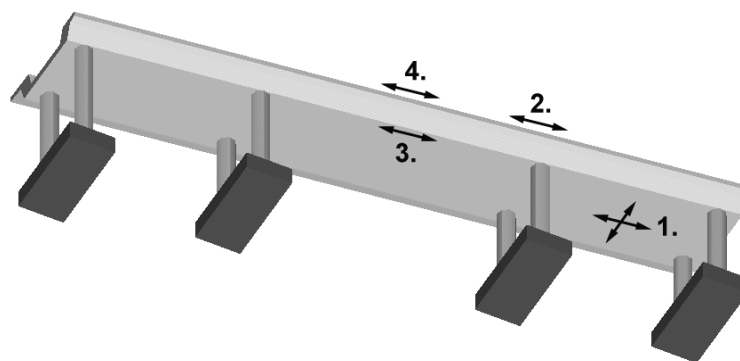

Figure 4-7: Locations of strain gauges

At Point 1 in Figure 4-7 strains have been measured both in the bridge's longitudinal and transverse direction. After the strengthening, the strains in the composite were also measured at this point. At Point 2, 3 and 4 the strains are only measured in the bridge's longitudinal direction. The strains have been measured with strain gauges welded to the old steel reinforcement, with the exception of Point 4 where the strain gauge was bonded to the concrete surface with an epoxy resin. The deformations have been recorded in the points shown in Figure 4-8. Only vertical deformations were measured.

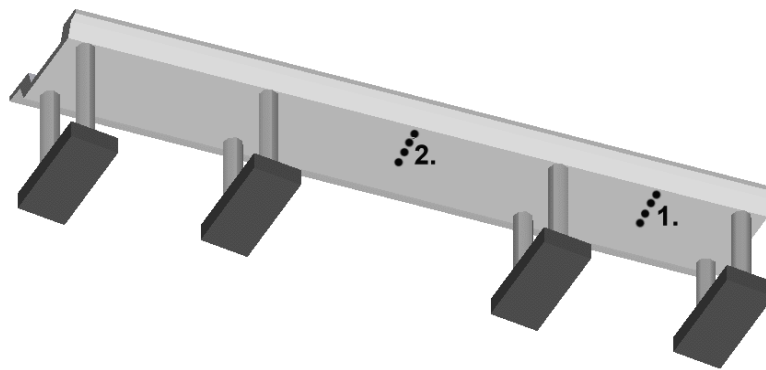

Figure 4-8: Locations of deformation measurements on the bridge

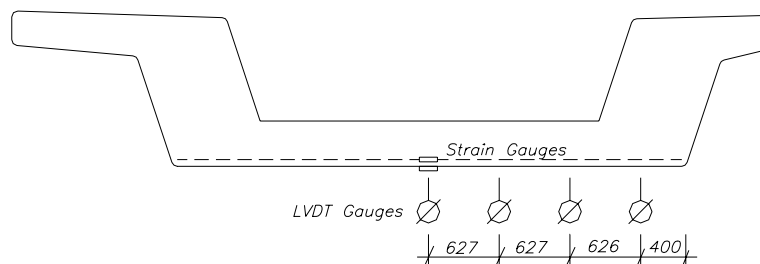

Figure 4-9: Locations of deformation measurements on the cross section

By reducing measured values with the deformation of the longitudinal beams the deformation of the trough was isolated, which is most interesting since it is only the trough that was strengthened.

## Results

In the following, mainly the strain measurements in the bridge's cross direction are reported. The measurements taken in the longitudinal direction didn't show any significant differences before and after strengthening. This is quite apparent since none, or only a small part of the strengthening system was bonded in a place or in a direction that would have decreased these strains. The fact that no difference was found validates the accuracy of the measurements. For evaluation of the strains,

averages for each train passing were formed. It was calculated taking the arithmetic mean value of the wagons. The studied wagons' chassis are almost identical. The divergences between single wagon baskets are insignificant and will not affect the average because of the large amount (52) of measured wagons in each train. For comparison the measured values are normalised from their weight to a 100 ton wagon weight.

The deflection of the trough in the cross direction, before and after strengthening shows a decrease of 16 %. After four years the same deformations as immediately after strengthening were measured. The measured strains from before strengthening, after strengthening and two years after strengthening, are shown in Figure 4-10. A decrease in strains of 15 % was achieved. The strengthening effect measured immediately after strengthening remained after two and four years.

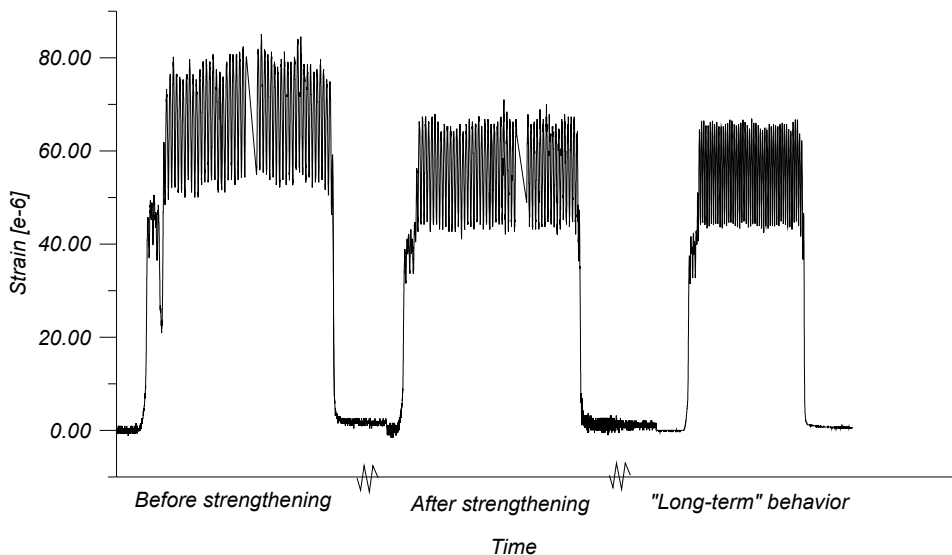

*Figure 4-10: Effect of strengthening on strain in the old steel reinforcement.*

The general appearance of the strain measurements will now be explained. Depending on where the train wheels are with respect to the measured point it will cause deformations and strains represented by either a dip or a top on the curve. The small registering at the beginning of each train set is the locomotive that runs over the bridge. The discontinuous parts of the graphs are due to the equipment used and should not be perceived as an error. It was a privation to be able to achieve the desired accuracy. At the time of the last measuring the available computer power had increased to a level where the privation was no longer necessary. The measurements of deformations have greater precision at lower train speed due to smaller vibrations but the average value is not affected by the train speed.

The measured strengthening effect is in accordance with theoretical calculations, which are presented in detail in Täljsten and Carolin (1999). Since the strengthening system was only four years old at the time of the last measurement it is not possible to make any long-term durability predictions. The results can however give an idea of a good short-term durability; after all it has been exposed to climate and real loads for four years.

### Experiences

Firstly, the tests show that a bridge can be significantly strengthened by CFRP plate bonding. The strengthening is possible to undertake on a real structure at a site. When the concrete is of high quality, sandblasting is not enough to uncover the aggregates. The wooden form work had also caused irregularities that needed to be ground down. For these two reasons, the pre-treatment work became work intensive and therefore costly. Afterwards it was noticed that an external reinforcement can be damaged from vehicle impacts. The application also shows that the strengthening can be undertaken with live loads acting on the bridge during the strengthening process. One issue that arose during the project is how the strengthened structure will act when a cold climate is prevalent. It is feared that the effect will decrease due to the different thermal coefficient for reinforced concrete and CFRP. Later research, (Carolin and Täljsten, 2002) has shown that this is not the case.

#### 4.3.2 Shear strengthening of T-beams

In Carolin and Täljsten (2003a) Appendix A, the importance of anchorage is presented. The anchoring may be a problem, especially for T-beams. In Figure 4-11 an ongoing shear strengthening of a T-beam in a parking deck is shown. The web is wrapped with carbon fibre fabrics, the fibres are bundled and taken through holes drilled in the slab and securely anchored on top of the slab.

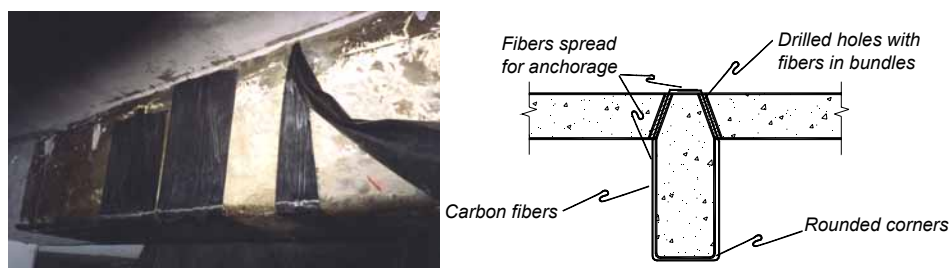

*Figure 4-11: Strengthening of T-beams with CFRP sheets. Holes are made in the slab to wrap the beam with the fibres.*

### 4.3.3 Gröndal and Alvik Bridges

Gröndal and Alvik Bridges are two large Freivorbau bridges (pre-stressed concrete box bridges), approximately 400 meters in length with a free span of 120 m and 140 m respectively. They were open to tram traffic in 2000. Just after opening, cracks were noticed in the webs, these cracks then increased and at the end of 2001 the bridges needed to be temporarily strengthened with externally placed pre-stressed steel stays. Figure 4-12 shows a sketch of the Gröndal Bridge with the larger cracks drawn.

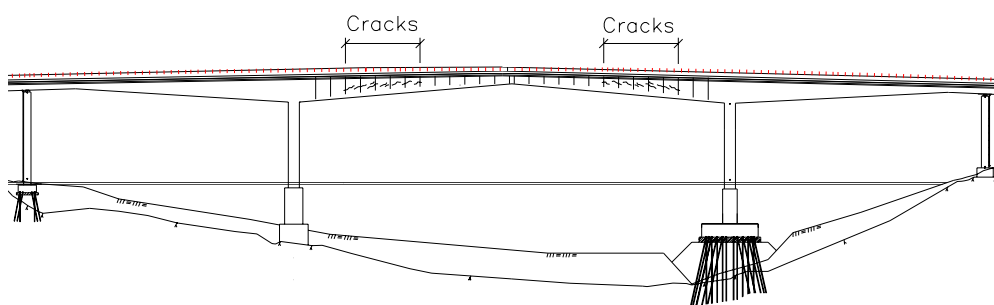

*Figure 4-12: Sketch of the Gröndal Bridge (Täljsten and Carolin, 2003)*

The reason for cracking depends on several factors but since a discussion on blame and responsibility is going on it will not be discussed in detail here. However, since shear cracks have occurred the principal tensile stresses in concrete have reached and exceeded the value of the tensile strength of the concrete. The positions of the cracks in longitudinal direction of the bridges correspond to the areas of the maximum principal tensile stresses. The observed crack widths, up to 0.5 mm, were caused by insufficient shear reinforcement in the webs.

In the regions where the largest cracks were found the bridges have been strengthened in the ultimate limit state with pre-stressed Dywidag stays. In areas where the bridge needed strengthening in service limit state carbon fibre laminates have been used. The purpose of strengthening was to inhibit existing cracks and prevent new cracks from developing. Due to the high degree of dead-load it was decided to use high modulus carbon fibre laminates to strengthen the bridges. For the strengthening in service limit state, the crack widths were the limiting factor. Cracks are not allowed to become larger than 0.3 mm. The design is not covered by existing codes and a fracture mechanics approach was used, (Täljsten and Carolin, 2003). The bridges are very important for the commuters and it was undesirable that the bridges were closed during strengthening. Based on the work presented in Carolin, et al., 2003, Appendix D, it was decided to carry out the strengthening with traffic during strengthening.

Laminates were only bonded on the inside of the bridges with a high quality epoxy adhesive, BPE<sup>®</sup> Lim 567, specific for the strengthening system used. A total of 6 000

meters of CFRP laminates was used for both the bridges, approximately 2 000 meters on the Gröndal bridge and 4 000 meters on the Alvik bridge. In Figure 4-13 the Gröndal Bridge can be seen on a touched up photo where the neighbouring bridge has been removed. The temporary stays can be seen on the outside of the structure and the laminates on the inside. The cracks had formed in a 30 ° direction and the laminates were placed perpendicular to the cracks.

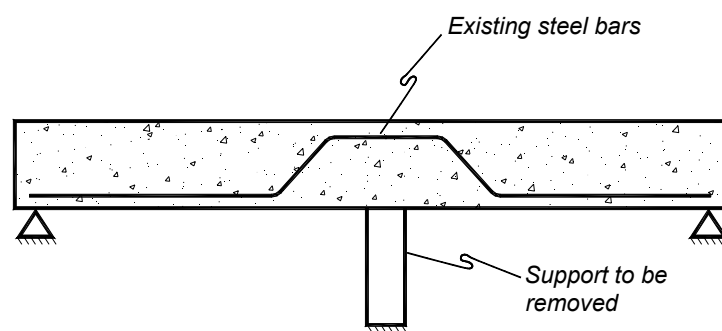

*Figure 4-13: Gröndal Bridge. Outside (left), Inside (right).*

Before bonding of the laminates the ordinary pre-treatment of the surface were undertaken and in addition holes were drilled in the upper and lower flanges for anchorage. All laminates were anchored by plates made by steel bonded in these holes. The work was carried out during the winter 2002/2003 and for that reason heat was applied in the boxes. To minimise the temperature differences between the inside and outside a maximum average working temperature of 15 °C was allowed, (Täljsten and Carolin, 2003). Measurements will be undertaken at specific locations to measure crack development, strain in steel reinforcement and on the CFRP laminates. The two bridges will be objects for structural health diagnostics, where measurements are connected to a calculation model and the behaviour of the strengthened bridges will be studied over time. The monitoring program will evaluate the effect from strengthening and preliminary results show that there is no increasing trend of the width of the existing cracks.

#### 4.3.4 Concrete overhead crane main girders

Strengthening can also be addressed by a change in a structural system. In this case the mid-supports for two two-span beams were taken away. The beams are main girders for an overhead crane and have 1 m by 2.3 m cross-sections. Almost all steel reinforcement in the middle of the beams was placed in the upper part of the cross-section due to the original design. In the lower part were only a few bars for assembly. After the mid-supports were removed, the spans of the two beams became 14.4 m and 16.8 m. The reinforcement and the change in structural system are schematically shown in Figure 4-14.



*Figure 4-14: Schematic sketch of steel reinforcement and change in structural system.*



*Figure 4-15: Finishing work on one of the beams*

The beams had large strengthening needs, in both flexure, about 12.5 MNm, and in shear, about 1 MN. The middle support was first partially removed. The beam was then strengthened for the dead load. A great advantage with this kind of change is that there are no initial tension strains in the most critical cross-section. The initial strains are instead in compression due to dead load. 24 layers, approximately 10 mm thick in total, were bonded as flexural reinforcement for each beam. 4 layers, 300 g/m<sup>2</sup> were used for shear strengthening on each side. The strengthening system BPE<sup>®</sup> Composite was used throughout the work. After strengthening the beams were painted with a grey colour, see Figure 4-15.

Measurements were undertaken on the strengthened beam with service loads. Naturally, it was not possible to do measurements on the new structural system before the strengthening was done. The measurements are not studied further in this study, but the beams managed to carry the load after strengthening and when the mid-supports had been removed.



## 5 RESEARCH AREAS

Previous chapters and the following Appendices A-E have identified some gaps in the knowledge in plate bonding with CFRP and some of these gaps will be further discussed here. The gaps have in some cases been filled by the present work and the results are summarised here and presented in the attached Appendices A-E. Obviously, not all identified gaps can be filled by this work and suggestions for further research are also presented.

### 5.1 General

One of the main issues when a new method is presented for the building industry is the durability and long-term behaviour. The durability of carbon fibres is generally considered to be good and the durability of epoxy may also be considered good as discussed in Chapter 3. However it is the durability and long-term behaviour of the structure that is most important. Composite action between the concrete and the fibres must be maintained. It is also important to know how the strengthening will affect the durability of the concrete. If plate bonding is used in an incorrect way so that humidity is trapped under a tight layer then there may be problems of freeze and thaw for the concrete and therefore the anchorage of the composite, (Gangarao and Vijay, 1997). However, tests have shown that plate bonding withstands temperature cycles very well if the moisture is below critical levels, (Tysl et al., 1998 and Hassanzadeh and Täljsten, 2002). Beaudoin et al. (1998) shows how wet-dry cycles without freezing affects the strengthening effect. Durability or long-term behaviour is not covered in this thesis but the testing of Kallkällan Bridge presented in Chapter 4 indicates good short-term behaviour without any reduction of strengthening effect after 4 years.

### 5.2 Shear

Research, laboratory tests and field applications have been carried out on many structures to restore or upgrade the flexural capacity while the shear capacity has not been addressed to the same extent, (Al-Sulaimani et al., 1994 and Diagana et al. 2003). When increasing flexure capacity, the structure will be loaded closer to its

maximum shear capacity. A beam must have a certain safety margin against shear failure since it is more dangerous and less predictable than flexural failure. Although not the only problem facing structures today, shear deficiencies are becoming more and more prevalent, (Diagana et al., 2003). Older design equations were much less stringent compared to the codes of today. In Sweden, the allowable shear stress for a typical concrete member has almost been cut by half from 1967 to 1979, (Carolin and Elfgren, 2002). All of these aspects combined with the reasons mentioned above give a great need for strengthening and retrofitting for increased shear capacity.

Most of the reported work is undertaken on rather small specimens, (Vaněk, 1986; Al-Sulaimani et al., 1994; Chajes et al., 1995; Sato et al., 1996; Norris et al., 1997; Chaallal et al., 1998b; Pellegrino and Modena, 2002 and Diagana et al., 2003). Carolin and Täljsten (2003a, Appendix A) present tests on strengthening for increased shear capacity of concrete structures beams 3.5 - 4.5 m long. One beam after failure can be seen in Figure 5-1.

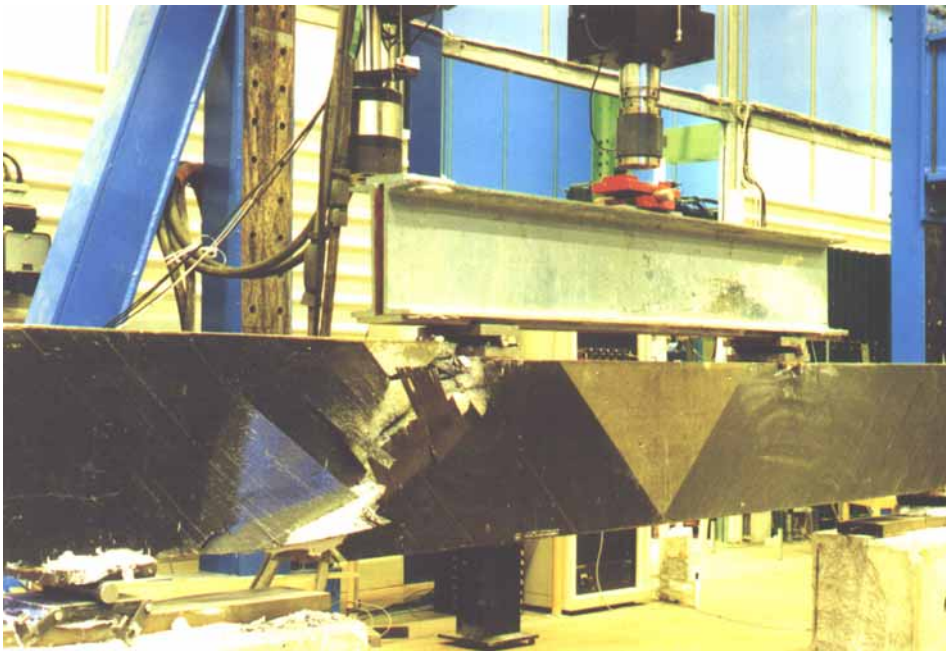

*Figure 5-1: Typical shear failure. (Carolin, 2001)*

The tests show that plate bonding with CFRP is an effective method for increase of the shear bearing capacity, and that a damage beam can be repaired not only to its original capacity but to a capacity above what it had before. A concrete beam may be strengthened so that the failure mode changes from shear to flexure. The tests also show that strains are not uniformly distributed over the cross-section of a rectangular beam. Together with the linear elastic properties of CFRP the strain field causes a

non-uniform stress field in the composites, see Figure 5-2. The design fibre strain can therefore not be used in the same way as the yield strain for steel stirrups.

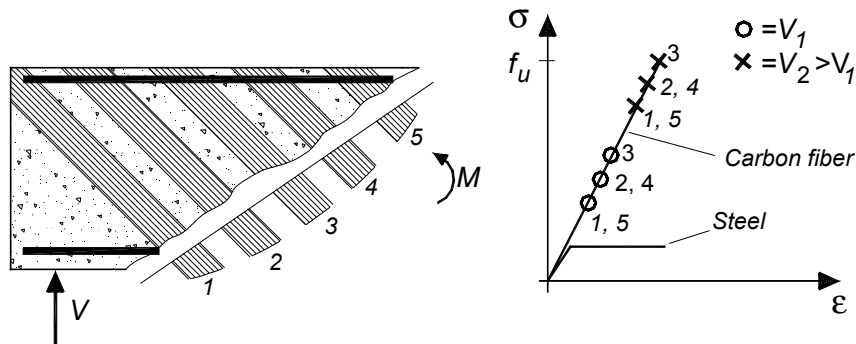

Figure 5-2: Stresses and strains over the height of the cross-section, (Carolin, 2001).

The strain distribution implies that when the first (centre) fibre reaches the ultimate capacity it ruptures and the neighbour fibres become more stressed and will also rupture. When calculating the contribution from fibres, depending on the location on the possible crack, i.e. height of the beam, the fibres will be stressed differently. Pure shear over an area is however very unusual in structural members. Most members are simultaneously subjected to both shear and flexural loading. The strain field is theoretically studied in Carolin and Täljsten (2003b, Appendix B). A reduction factor based upon the strain distribution must be used in designing with the truss model. In Figure 5-3 theoretically determined strain fields are compared to measured strain fields from tests presented by Carolin and Täljsten (2003a, Appendix A).

The strain distribution gives that the average fibre utilisation is only about 0.6, (see further Carolin and Täljsten, 2003b, Appendix B). The truss model can be used to satisfactorily describe the contribution from externally bonded carbon fibre polymers. In the truss model, limitations on maximum allowable strain must be considered for, fibre rupture, anchorage and contribution from concrete..

The fresh ideas in Carolin and Täljsten (2003a, Appendix A and 2003b, Appendix B) are the laboratory investigation and analytical calculation of the average fibre strain utilisation due to linear-elastic behaviour of the material used. Placing limitations on principal strain direction in concrete instead of fibre direction is also a new way of thinking.

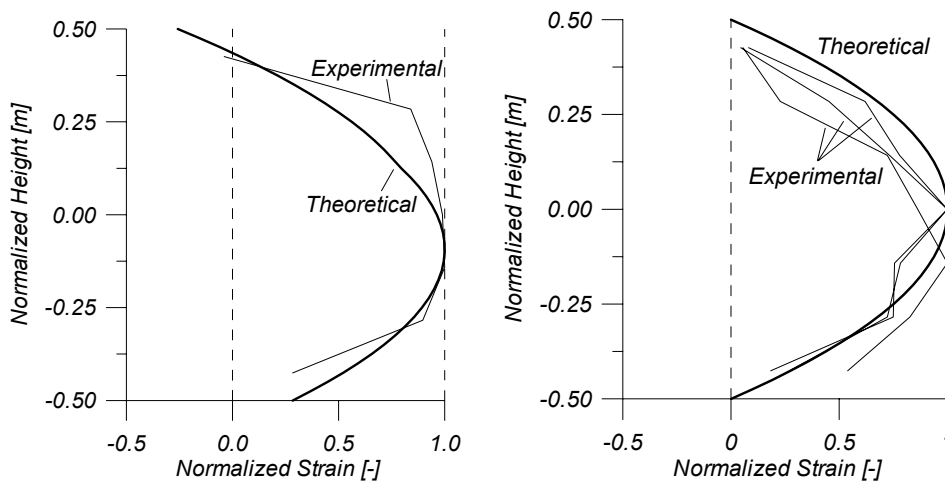

Figure 5-3: Strain profile at 285 kN, fibre directions 45 ° (left) and 90 ° (right)

### 5.3 Bending

Three issues arose during strengthening of the Kallkällan Bridge presented in Chapter 4; damages of strengthening due to vehicle impacts, strengthening effect in cold climate and the affect from live loads acting during strengthening.

Some protection for the strengthening can be reached by using the NSMR method which means that the strengthening is inserted in the concrete cover. Grooves are cut by a concrete saw that give slots with two parallel fairly smooth sides and one rough side at the bottom, (Figure 5-4A). After the grooves are made, they are cleaned with pressurised air and then half-filled with adhesive, (Figure 5-4B). The rods are then placed so that the grooves are completely filled and the rods have adhesive on three sides, (Figure 5-4C). Due to the geometry of the grooves and practical considerations Täljsten et al. (2003, Appendix C) suggest that quadratic rods should be used.

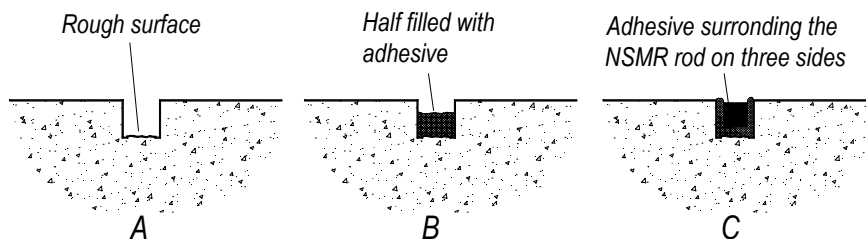

Figure 5-4: Procedure for strengthening with NSMR

When it is possible to use NSMR it might offers better anchorage in the concrete, some protection for the strengthening system, and in some cases also easier installation. The shear force is transferred into the rod on three sides, which makes peeling forces at the end less critical compared to traditional plate bonding, (Täljsten et al., 2003, Appendix C). Blaschko (2001) have studied rectangular laminates in narrow deep slots. De Lorenzis and Nanni (2002) and Rizkalla and Hassan (2001) have bonded circular rods into more or less rectangular grooves. All undertaken research shows that there is no doubt that strengthening concrete structures with NSMR is an effective method. The effect of cold climate has been tested for NSMR and presented by Carolin and Täljsten (2002) and is not further discussed here.

Most laboratory studies, with both NSMR and traditional plate bonding, have been carried out on beams placed upside down on a flat surface when the strengthening has been applied. This means that the beams are completely unloaded, including self-weight, when the CFRP is bonded to the structure. Some studies have been undertaken with a strain field on the strengthened cross-section, i.e. dead load, (Weijian and Huiming, 2001 and Shin and Lee, 2003). Initial strains on a cross-section can be handled in most design proposals, (Täljsten 2002). Studies with a strain field changing over time have not previously been reported. This corresponds to live loading during the strengthening process, i.e. for example traffic on a bridge during curing of the adhesive, and is presented in Carolin et al. (2003a, Appendix D). Both laminate plate bonding and the use of NSMR have been investigated for strengthening of beams. For the NSMR applications both epoxy and a cementitious bonding agent have been studied.

Every 108 seconds during the strengthening process one “sinus shaped” load cycle with a maximum of 40 kN was applied and then the beam was unloaded to 5 kN. The load interval corresponds approximately to 7 % - 54 % of the capacity of a non-strengthened member. The effect of the strengthening system during curing of the adhesive is shown in Figure 5-5. The plotted values are measured at the maximum load for every load cycle. The figure shows on the left vertical axis the strains over the cross-section for a typical case. The mid-point deflection is also plotted in the same figure with numbers on the right vertical axis. The hardening process can be divided into three distinctive stages, (see Figure 5-5).

The strains are quite stable until initiation of polymer setting, stage 1, which seems to occur approximately at 4 hours. As the epoxy cures the composite rods start to be stressed, meanwhile the steel bars are unloaded, stage 2. After setting of the polymer, another 4 hours, peak strains are unaffected during the remaining load cycles, stage 3. The mid-point deflection decreased with up to 38 % during hardening of the adhesive. The beams were later loaded to failure. For the beams strengthened by laminate plate bonding or NSMR with epoxy, the cyclic loads do not significantly affect the strengthening effect for the tested beams. The use of cementitious mortar together with NSMR is not suitable when cyclic loads are prevailing during hardening of the adhesive. However, a cementitious bonding agent together with NSMR does work

satisfactorily when it cures under static conditions. Further details are presented in Carolin et al., (2003a, Appendix D).

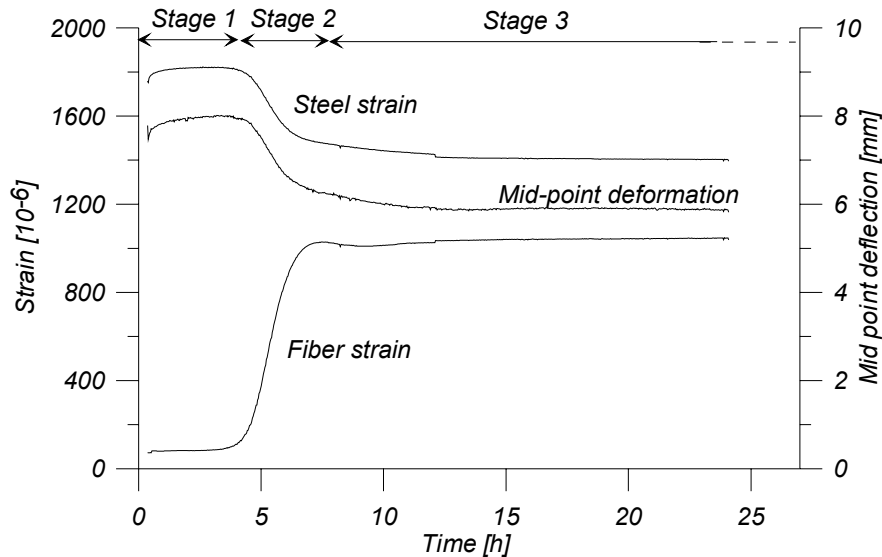

Figure 5-5: Typical cross-section strains and mid point deformations at peak load for every load cycle.

The ideas presented in Täljsten et al., (2003, Appendix C) where FRP rods with quadratic cross-sections are applied into grooves in the concrete cover are new. Live loading during application of strengthening system of CFRP presented in Carolin et al., (2003a, Appendix D) have furthermore not been previously reported, neither for NSMR nor laminate plate bonding.

#### 5.4 Buckling

When Luleå University of Technology was asked about the possibility to increase the buckling load for slender steel members no such work could be found in the literature. External bonding of CFRP has however been used for flexural strengthening of steel, (Sen et al., 1995). Normally in plate bonding, composites are bonded as an additional reinforcement to carry tensile forces. Buckling may occur for members subjected to compression. Axially loaded members can be found almost everywhere. Trusses, that are used for bridges, masts and beams, consist of many members subjected to more or less pure compression. In Carolin et al. (2003b, Appendix E) the possibility of using fibre composites for increasing the global buckling load for steel pipes subjected to pure compression has been investigated. The work includes a theoretical study as well as full-scale tests. The theoretical work consists of both analytical and numerical finite element calculations.

Strengthening along the whole length is not the most economical way for strengthening for increased stability. The greater part or the strengthening material should be applied in the midsection of the truss. The buckling mode of a truss member with higher moment of inertia in the midsection,  $I_{str}^* > I_s$ , is shown in Figure 5-6.

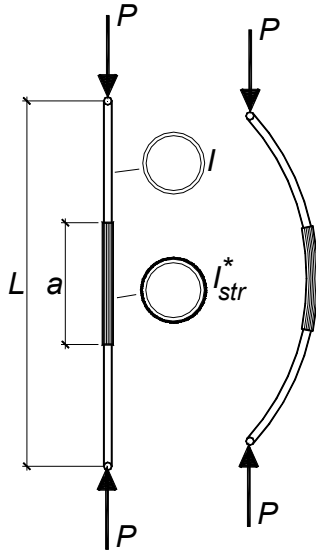

Figure 5-6: Truss element partially strengthened

By using an energy approach, the critical load for a member with higher stiffness in the midsection, may be analytically determined and the critical load for the member may be written as:

$$P_{cr} = \frac{\pi^2 E_s I_{str}^*}{L^2} \frac{1}{\frac{a}{L} + \frac{L-a}{L} \frac{I_{str}^*}{I_s} - \frac{1}{\pi} \left( \frac{I_{str}^*}{I_s} - 1 \right) \sin \frac{\pi a}{L}} \quad (5-1)$$

For detailed derivation and explanation of variables see Carolin et al., (2003b, Appendix E). Sometimes truss members may have installations in the midsection which make strengthening in the centre complicated or impossible. This means that the strengthening needs to be split into two parts with a gap between, or that the strengthening must be applied somewhat dislocated from the centre. It is possible to derive equations for any strengthening configuration. However, the expressions start to become complicated with just one change in cross-section as presented above in Equation (5-1). To solve the problem with non-uniform cross-sections or non-symmetrical strengthening a numerical approach is suggested in Carolin et al., (2003b, Appendix E). The tests show that fibre composites can be used for strengthening of

axially loaded truss members and derived models may be used to calculate the strengthening effect.

The presented research on structural strengthening in buckling (Carolin et al., 2003b, Appendix E) covers a new area for increase of load bearing capacity with CFRP. The new ideas include laboratory testing and derivation of an analytical model.

### **5.5 Further research**

The research has uncovered some areas open for research both within studied topics and in adjacent topics within the area of strengthening of structural elements. In the following section some areas for further research will be given.

Generally, a limited amount of research has been undertaken regarding size effect, service limit state, reliability and durability. Laboratory testing is often done on scale specimens. For comparison between scale specimens and real structures, the size effect must be completely understood regarding strengthening effect and affect on failure modes. More research can be undertaken to investigate the strengthening effect in the service limit state. Methods for estimating crack risks and crack widths may be improved.

Research on strengthening for increased shear bearing capacity has in many cases been undertaken on unloaded beams. The strengthening effect when elements are strengthened in shear with loads acting during the strengthening process should be studied; both for members pre-cracked in shear and non pre-cracked members. Many T-beams have been studied in strengthening for increased shear capacity simultaneously subjected to flexural moments causing compression in flange. The anchorage situation for the strengthening may be different if the flange is subjected to tension, like the situation at a mid-support. Furthermore, the anchorage situation when strengthening for increased shear capacity where direction of principal strain and fibre direction is different should be studied. Strain limitations for when the concrete still has a shear bearing capacity should also be further studied.

In regard of near surface mounted reinforcement, the bond mechanics for quadratic rods applied in grooves may be better defined.

Presented study with live loads during strengthening may be extended with different load levels and load frequencies. The same study or a similar should also be undertaken for strengthening with hand lay-up systems with fabrics.

A limited amount of tests were undertaken for improvement of buckling loads of steel members. More tests should be undertaken to investigate the accuracy of the derived model, especially for higher strengthening effects. The tested method of hand lay-up works well in a laboratory environment, but might be difficult to employ on real structures. Methods where pre-manufactured shells that can be bonded to the truss members may be developed.

There are several other topics within strengthening of structural members with CFRP, and the connected usage of these materials in civil engineering. To utilise the



full capacity of carbon fibres they may be pre-stressed. Nordin (2003) shows that strengthening a member with pre-stressed fibres may result in an increase of the stiffness, increased load when internal steel is yielding and increase of load when concrete starts to crack. Pre-stressing has also been used for shear strengthening by Lees et al. (2002).

More research may be undertaken regarding reliability when strengthening by externally bonded CFRP. The reliability of existing prediction models and the distribution of influencing variables may be combined for a deeper understanding of the reliability of a strengthened structure.

Due to the limited knowledge on durability and long-term behaviour of real strengthened structures, already strengthened structures should be kept under surveillance. This raises another research area for CFRPs in civil engineering - monitoring. A small amount of fibres that rupture at a certain strain may be included in a composite with a higher rupture strain, to indicate when the composite has been stressed to a critical level. Optical fibre with sensors may be integrated in composites used for strengthening. This results in the fact that the strengthening will not only improve the bearing capacity of the structure, but also be used to achieve information of the condition of the structure. The electrical properties of the carbon fibres may also be used for measurements of the behaviour of the structure.

A typical situation that requires strengthening is when openings are going to be made in joists. This has been studied by Ericsson and Larsson (2003) on rectangular slabs simply supported at the four outer edges and loaded by uniform load. However, more analysis and more testing is needed to get a complete understanding of the behaviour of such structural systems. The use of carbon fibre grids bonded with cement grout to a concrete surface for flexural strengthening has been studied by Becker (2003). The method should also be studied for strengthening in shear. Finally, most likely there exist several undiscovered potential areas for the use of CFRPs in civil engineering that will be discovered in the nearby future.



## 6 REFERENCES

- ACI Committee 440 (1996) "*State-of-the-Art Report on Fiber Reinforced Plastic Reinforcement for Concrete Structures*", American Concrete Institute, Farmington Hills, Michigan, February 1996, p 68.
- Agarwal B.D. and Broutman L.J., 1990, "*Analysis and Performance of Fibre Composites*", 2<sup>nd</sup> edition John Wiley & Sons Inc., ISBN 0-471-51152-8, 1990, p 449.
- Al-Sulaimani, G. J., Sharif, A., Basunbul, I. A., Baluch, M. H. and Ghaleb, B. N. (1994): "Shear Repair for Reinforced Concrete by Fiberglass Plate Bonding", *ACI Structural Journal*, July-August, pp. 458-464
- Alexander, J. G. S. and Cheng, J. J. R. (1996): "Field application and studies of using CFRP sheets to strengthen concrete bridge girders" *Advanced Composite Materials in Bridges and Structures*, El-Badry, M. M., Ed., pp 465-472
- Alkhrdaji, T., Thomas, J., Nanni, A., and Huck, M. (2002): "Strengthening of Off-Systems Bridges Using FRP Composites" *Proc. of Third Int. Conf. on Composites in Infrastructure*, San Fransisco, june, Omnipress.
- Apinis, R., Modniks, J., Tamužs, V. and Teffers, R. (1998): "*Ductility of Hybrid Fiber Composite Reinforced FRP for Concrete*" Report, Chalmers University of Technology. 11 pp.
- Asplund, S.O. (1949): "Strengthening Bridge Slabs with Grouted Reinforcement", *Journal of the American Concrete Institute*, Vol. 20, No. 6, January, pp. 397-406.
- Augustsson, C. (1995), Nils Malmgren AB "*NM Epoxi handbok*", Rollsbo: Tryck & Reklam AB, In Swedish.
- Banverket (1996): "*30 ton på malmbanan*", Luleå: Banverket. Ed. Paulsson, B.(in Swedish) October.
- Beaudoin, Y., Labossière, P. and Neale, K. (1998): "Wet-dry actions on the bond between composite materials and reinforced concrete beams" *Proc. of Durability of Fibre Reinforced Polymer (FRP)*, Sherbrooke, ISBN 0-921303-88-2, pp 537-546

- Becker, D. (2003): “*Betongplattor förstärkta med kolfiberkomposit*” (Concrete slabs strengthening with carbon fibre composites, In Swedish), Luleå Univ. of Tech., Div Structural Engineering. Master thesis 2003:130.
- Bencardino, F., Spadea, G. and Swamy, N. (2002): “Strength and Ductility of Reinforced Concrete Beams Externally Reinforced with Carbon Fiber Fabric” *ACI Structural Journal*, Mar-Apr, pp. 163-171.
- Benmokrane, B and Rahman, H (1998): “Durability of fibre reinforced polymer (FRP) composites for construction”, Montreal: Avantage Inc. *Proceedings of the International Conference CDCC'98*. 692 pp.
- Betonghandboken (1994): “*Material*”, (Handbook for Concrete - Material, In Swedish), Second edition, Solna: AB Svensk Byggtjänst. 1127 pp.
- BKR 94 (1994): “*Konstruktionsregler*”, (Design guidelines, in Swedish)Solna: Svensk Byggtjänst, 177 pp.
- Blaschko, M. A. (2001): “*Zum Tragverhalten von Beetonbauteilen mit in Schlitz eingeklebten CFK-Lamellen*” Doctoral Thesis ISSN: 0941-925X, 150 pp In German.
- Breña, S., Bramblett, R., Wood, S. and Kreger, M. (2003): “Increasing Flexural Capacity of Reinforced Concrete Beams Using Carbon Fiber-Reinforced Polymer Composites” *ACI Structural Journal*, Jan-Feb, pp. 36-46.
- Bresson J., (1971), “Nouvelles recherches et applications concernant l'utilisation des collages dans les structures”, *Beton plaque Annales de l'institute technique du BTP*, Paris. No. 278, 1971.
- Burgoyne, C. J. (1999): “Advanced Composites in Civil Engineering in Europe” *Structural Engineering International, Journal of the IABSE*, V. 9 No. 4, November pp.267-273.
- Carolin, A. (1999): “*Improvement of the Load-Bearing Capacity of Existing Bridges: A review of literature*” Technical report 1999:19, Luleå: Luleå University of Technology. 31 pp. ISSN 1402-1532.
- Carolin, A. (2001): “*Strengthening of Structures with CFRP*” Licentiate thesis 2001:01, Luleå University of Technology. Div. of Structural Engineering
- Carolin, A. and Elfgrén, L. (2002): “*Shear and Torsion*” Technical report 2002:22, Luleå university of Technology, Division of Structural Engineering.
- Carolin, A. and Täljsten, B. (2002): “Behaviour of concrete beams strengthened with near surface mounted reinforcement, NSMR”, *Proceedings of ACIC2002*, Southampton, April 2002. 9 pp.
- Carolin, A. and Täljsten, B. (2003a): “Experimental Study on Strengthening for increased Shear Bearing Capacity” *Journal of Composites for Construction*. Submitted (Appendix A)

- Carolin, A. and Täljsten, B. (2003b): "Theoretical Study on Strengthening for Increased Shear Bearing Capacity" *Journal of Composites for Construction*. Submitted (Appendix B)
- Carolin, A. Täljsten, B. and Hejll, A. (2003a): "Concrete Beams Exposed to Live Loading during CFRP Strengthening" *Journal of Composites for Construction*. Submitted (Appendix D)
- Carolin, A., Täljsten, B. and Åström, L. (2003b): "Stability Improvement of Axially Loaded Steel Members by CFRP Strengthening" *Steel & Composite Structures – An Int. J.* Submitted (Appendix E)
- Chaallal, O., Nollet, M.-J., and Perraton, D. (1998a): "Strengthening of reinforced concrete beams with externally bonded fiber-reinforced-plastic plates: Design guidelines for shear and flexure", *Canadian Journal of Civil Engineering*, pp. 692-704
- Chaallal, O., Nollet, M.-J., and Perraton, D. (1998b): "Shear Strengthening of RC Beams by Externally Bonded Side CFRP Strips", *Journal of composites for construction*, May, pp. 111-113
- Chaallal, O., Hassan, M. and Shahawy, M. (2003): "Confinement Model for Axially Loaded Short Rectangular Columns Strengthened with Fiber-Reinforced Polymer Wrapping" *ACI Structural Journal*, Mar-Apr, pp. 215-221.
- Chajes, M. J., Januszka, T. F., Mertz, D. R., Thomson, T. A. Jr. and Finch, W. W. Jr. (1995): "Shear strengthening of Reinforced concrete beams Using Externally Applied Composite Fabrics" *ACI Structural Journal* V.92, No.3. pp. 295-303
- De Lorenzis, L (2002): "*Strengthening of RC structures with near-surface mounted FRP rods*" Doctoral Thesis, Univ. of Lecce, Italy, pp 297.
- De Lorenzis, L. and Nanni, A. (2002): "Bond between Near-Surface Mounted Fiber-Reinforced Polymer Rods and Concrete in Structural Strengthening" *ACI Structural Journal*, Mar-Apr, pp.123-132.
- Dejke, V. (2001): "*Durability of FRP Reinforcement in Concrete. Literature Review and Experiments.*" Licentiate thesis, Chalmers, Göteborg. 211 pp.
- Diagana, C., Li, A., Gedalia, B. and Delmas, Y. (2003): "Shear strengthening effectiveness with CFF strips" *Engineering structures* 25 pp 507-516.
- Dussek I.J., (1974), "*Strengthening of bridge beams and similar structures by means of epoxy-resin-bonded external reinforcement*", Transport and research record 785, Washington, USA, 1974, pp 21-24.
- Ericsson, A. and Larsson, T. (2003): "*Kolfiberförstärkning av plattor med hål*" (CFRP strengthening of slabs with openings, In Swedish), Master thesis, Luleå Univ. of Tech. Div. of Structural Engineering. To be printed.
- Erki, M.-A. (1999): "Fibre-Reinforced Polymers for Structural Engineering in Canada" *Structural Engineering International, Journal of the IABSE*, V. 9 No. 4, November pp.278-280.

- Eurocode 2, ENV 1992-1-1:1991 (1991): "*Eurocode 2: Design of Concrete Structures – Part 1: General Rules and Rules for Buildings*", CEN (Comité Européen de Normalisation), European Committee for Standardisation, Central Secretariat, Brussels, 230 pp
- Fukuyama, H. (1999): "Fibre-Reinforced Polymers in Japan" *Structural Engineering International, Journal of the IABSE*, V. 9 No. 4, November pp.263-266.
- Gabrielsson, H. (1999): "*Ductility in High Performance Concrete Structures, An experimental Investigation and a Theoretical Study of Prestressed Hollow Core Slabs and Prestressed Cylindrical Pole Elements*", Doctoral thesis 1999:15, Luleå University of Technology. Div of Structural Engineering
- Gangarao H. V. S. and Vijay P. V. (1997): "Aging of Structural Composites under Varying Environmental Conditions." *Non-Metallic (FRP) Reinforcement for Concrete Structures: Proceedings of the Third International Symposium*, Vol 2, Sapporo, Oct. 1997, pp. 91-98.
- Garden, H N, Quantrill, R J, Hollaway, L C, Thorne, A M, Parke, G A R (1998) "An experimental study of the anchorage length of carbon fibre composite plates used to strengthen reinforced concrete beams" *Construction and Building Materials*, Elsevier #12 1998.
- Gemert, D van (1996): "Design applications and durability of plate bonding technique". *Proceedings of the International Conference on Concrete Repair, Rehabilitation and Protection*, Scotland. London: Chapman & Hall. pp 559-569. ISBN 0 419 21490 9.
- Ghobarah, A., Ghorbel, M. N. and Chidiac, S. E. (2002): "Upgrading Torsional Resistance of Reinforced Concrete Beams Using Fiber-Reinforced Polymer", *J. of Comp. for Construction*, Nov, pp. 257-263
- Grace, N., Abdel-Sayed, G. and Ragheb, W. (2002): "Strengthening of Concrete Beams Using Innovative Ductile Fiber-Reinforced Polymer Fabric" *ACI Structural Journal*, Sep-Oct, pp 692-700
- Hassanzadeh, M. and Täljsten, B. (2002): "Frost-behavior of CFRP strengthened concrete beams" *Proc. Nordic Concrete Research Meeting*, Esinore, Denmark. Oslo: Nordic Concrete Research, pp 254-256.
- Hedin, J. and Lundin, K. Eds. (1993): "*Stålbyggnad*" (Steel structures, In Swedish) 326 pp.
- Hull, D, Clyne, T, W (1996): "*An Introduction to Composite Materials*". Cambridge: Cambridge University Press, ISBN 0-521-38855-4. 326 pp.
- Iyer S.L., Sivaramakrishnan C. and Amaram S., (1989), "Testing of reinforced concrete bridges for external reinforcement", *Proceedings Relating to Structural Materials, Structures Conference, ASCE New York*, May 1989, pp 116-122.
- Jasienko J. and Leszczynski J., (1990), "Examination of ferro-concrete beams strengthen with externally bonded reinforcement in compressed zone", *Int.*

- Seminar Structural Repairs/Strengthening by the Plate Bonding Technique*, University of Sheffield, sept. 1990, p. 6.
- Karbhari, V. and Seible, F. (1999): "Fibre-Reinforced Polymer Composites for Civil Infrastructure in the USA", *Structural Engineering International, Journal of the IABSE*, V. 9 No. 4, November pp.274-277.
- Khalifa, A., Alkhrdaji, T., Nanni, A. and Lansburg, S. (1999): "Anchorage of Surface Mounted FRP Reinforcement", *Concrete International*, V. 21, No. 10 pp. 49-54.
- Klaiber F.W., Dunker K.F., Wipf T.J. and Sanders JR W.W.: (1987), "*Methods of strengthening existing highway bridges*", Transportation Research Board, Washington D.C., Sept. 1987, p. 16.
- L'Hermite, (1967), "*L'application des colles et resines dans la construction*", La betong a coffrage portant, Annales l'instutute technique, No. 239, 1967.
- Labossière, P., Neale, K.W., Rochette, P., Demers, M., Lamothe, P., Lapierre, P. and Desgagné, G. (2000): "Fibre reinforced polymer strengthening of the Sainte-Émélie-de-l'Énergie bridge: design, instrumentation, and field testing" *Can. J. Civ. Eng.* 27. pp 916-927
- Ladner M. und Flueler P., (1974), "*Versuche an Stahlbetonbauteilen mit geklebter Armierung*", Schweizerische Bauzeitung, Heft 19, Mai 1974, pp 9-16.
- Lane, J, Fashole-Luke, S, Skwarski, A (1998): "Strengthening with carbon fibre", *Concrete*, Vol32 No1, pp 14- 15.
- Lees, J. M., Winistörfer, A. U. and Meier, U. (2002): "External Prestressed Carbon Fiber-Reinforced Polymer Straps for Shear Enhancement of Concrete", *J. of Comp. for Construction*, Nov, pp 249-256.
- Lerchenthal H., (1967), "Bonded sheet metal reinforcement for concrete slabs", *Bullentin in RILEM*, No. 37, December 1967, pp 263-269.
- Levar, J. and Hamilton III, H.R. (2003): "Nondestructive Evaluation of Carbon Fibre-Reinforced Polymer-Concrete Bond using Infrared Thermography" *ACI Materials Journal*, February, pp. 63-72.
- Li, V C (1998): "Repair and Retrofit with Engineered Cementitious Composites", *Proceedings of FRAMCOS-3 conference on Fracture Mechanics of Concrete Structures*. Freiburg: AEDIFICATO, Germany. Vol. 3 pp 1715- 1726. ISBN 3-931681-24-6.
- Malek, A. M., Saadatmanesh, H (1998a): "Analytical Study of Reinforced Concrete Beams Strengthened with Web-Bonded Fiber Reinforced Plastic Plates or Fabrics" *ACI Structural Journal*, May-June 1998, pp. 343-352.
- Mallet, G P (1994), "*Repair of concrete bridges*", London: Thomas Telford, ISBN 0 7277 2007 4. 194 pp.
- Meier, U. (1999): "Structural Tensile Elements made of Advanced Composite Materials" *Structural Engineering International, Journal of the IABSE*, V. 9 No. 4, November pp.281-285.

- Micelli, F., Annaiah, R. and Nanni, A. (2002): "Strengthening of Short Shear Span Reinforced Concrete T Joists with Fiber-Reinforced Plastic Composites" *J. of Comp. for Construction*, Nov, pp. 264-271.
- Monti, G. and Santini, S. (2002): "Reliability-based Calibration of Partial Coefficients for Fiber-Reinforced Plastic" *Journal of Composites for Construction*. August. pp 162-167
- Nordin, H. (2003): "*Fibre Reinforced Polymers in Civil Engineering - Flexural Strengthening of Concrete Structures with Prestressed Near Surface Mounted CFRP Rods*" Licentiate Thesis, Luleå Univ. of Tech., Div. of Structural Engineering. To be presented in June.
- Norris, T., Saadatmanesh, H. and Ehsani, M. R. (1997) "Shear and flexural strengthening of R/C Beams with Carbon Fiber Sheets" *Journal of structural engineering*, V123, No. 7 pp. 903-911
- Okorowski, B et al (1996): "Numerical simulation of concrete repair methodology based on fibre reinforced cover sheets". *Proceedings of the International Conference on Concrete Repair, Rehabilitation and Protection*, Scotland. London: Chapman & Hall. pp 467-472. ISBN 0 419 21490 9.
- Palmer P.M., (1979), "*Repair and maintenance of concrete bridges with particular reference to the use of epoxies*", Tech. Report No. 14, Main Roads Dept., Perth, Western Australia, august 1979.
- Pellegrino, C. and Modena, C. (2002): "Fiber reinforced polymer Shear Strengthening of Reinforced Concrete Beams with Transverse Steel Reinforcement" *Journal of Composites for Construction* May pp104-111
- Plevris, N., Triantafillou, T. and Veneziano, D. (1995): "Reliability of RC Members Strengthened with CFRP Laminates" *Journal of Structural engineering*. July, pp. 1037-1044.
- Raithby K.D., (1980), "*External strengthening of bridges with bonded steel plates*", Transport and road research laboratory, Report 612, Crowthorne, Berkshire, 1980, p 21.
- Rizkalla, S. and Hassan T. (2001): "Various FRP strengthening techniques for retrofitting concrete structures" *International Conference on FRP Composites in Civil Engineering*, Volume 2, J.-G. Teng (Ed). ISBN: 0-08-043945-4 pp 1033-1040
- Rådman, J. (1998): "*Development of concrete compressive strength: a study of Swedish bridges constructed during the 20th century*", Luleå: Luleå University of Technology. Division of Structural Engineering., Master Thesis 1998:258, IDNR: 992861308.
- Sato, Y., Ueda, T., Kakuta, Y. and Tanaka, T. (1996) "Shear Reinforcing Effect of Carbon Fiber Sheet Attached to Side of Reinforced Concrete Beams" *Advanced Composite Materials in Bridges and Structures*, El-Badry, M. M., Ed., pp 621-628



- Seible, F., Priestley, M. J. N., Hegemier, G. A. and Innamorato, D. (1997): "Seismic Retrofit of RC Columns with Continuous Fiber Jackets", *Journal of Composites for Construction*, No. 1, pp.52-62.
- Sen, R., Liby, L., Spillet, K. and Mullins, G.(1995): "Strengthening steel composite bridge members using CFRP laminates". *Non-metallic (FRP) Reinforcement for Concrete Structures*. Ed L. Taerwe. E&FN Spon, 551-558. ISBN 0 419 20540 3..
- Shehata, I et al (1996): "Structural repair of RC beams in shear". *Proceedings of the International Conference on Concrete Repair, Rehabilitation and Protection*, Scotland. London: Chapman & Hall pp 615-622. ISBN 0 419 21490 9.
- Shin, Y.-S., and Lee, C. (2003): "Flexural Behavior of Reinforced Concrete Beams Strengthened with Carbon Fiber-Reinforced Polymer Laminates at different Levels of Sustaining Load." *ACI Structural Journal* Mar-Apr, pp.231-239
- Swamy R.N. and Jones R., (1980), "Technical notes – Behaviour of plated reinforced concrete beams subjected to cyclic loading during glue hardening", *The int. Journal of Cement Composites*, Vol. 2, No. 4, Nov. 1980, pp 741-755.
- Tepfers, R. (2000): "*Bond of reinforcement in concrete*" Ed. International Federation for Structural Concrete (*fib*), Bullentin 10, 427 pp
- Thériault, M. and Neale, K. (2002): "Simplified design equations for reinforced concrete columns confined with FRP wraps", *Proc of FRP Comp. in Civil Eng.*, Ed. Teng, J.G. ISBN0-08-043945-4 Volume 2 pp 741-748.
- Thun, H. (2001): "*Evaluation of concrete structures. Strength development and fatigue capacity*" Licentiate thesis 2001:25 Luleå: Luleå University of Technology. ISBN 91-89580-08-2, 164 pp
- Tysl S. R., Imbrogno M. and Miller B. D. (1998): "Effects of Surface delamination on the Freeze/Thaw Durability of CFRP-Reinforced Concrete Beams." *Proceedings from the First International Conference on Durability of Fibre Reinforced Polymer (FRP) Composites for Construction*, Sherbrooke, August, 1998, pp. 317-324.
- Täljsten B., (1990), "*Förstärkning av betongkonstruktioner genom pålimning av stålplåtar*" (Strengthening of concrete structures by bonded steel plates, In Swedish), Luleå University of Technology, Division of Structural Engineering, Licentiate thesis 1990:06L, p 212.
- Täljsten, B. (1994): "*Plate bonding, Strengthening of existing concrete structures with epoxy bonded plates of steel or fibre reinforced plastics*" Doctoral Thesis1994:152 D, Luleå University of Technology. Division of Structural Engineering. August 1994. 290 pp
- Täljsten, B (1996): "Strengthening of existing concrete structures by epoxy bonded steel plates of steel or fibre reinforced plastics". *Proceedings of the International Conference on Concrete Repair, Rehabilitation and Protection, Scotland*. London: Chapman & Hall. pp 623-632. ISBN 0 419 21490 9.
- Täljsten B., (1997), "Strengthening of concrete structures for shear with bonded CFRP-fabrics", *Recent advances in bridge engineering, Advanced rehabilitation*,

- durable materials, nondestructive evaluation and management*, Eds. U. Meier and R. Bettid, Dubendorf July 1997, pp 57-64.
- Täljsten, B. (2000): "Strengthening of Concrete Structures with CFRP-Sheets. Applications and Full Scale Test in Sweden" *Advanced Composite Materials in Bridges and Structures, Proc. of 3rd Int. Conf.*, Ed. Humar, J.L. and Razaqpur, A.G. Ottawa, ISBN: 0-7709-0447-5, pp. 513-520.
- Täljsten, B. (2002): "*FRP Strengthening of Existing Concrete Structures: Design Guidelines*". Luleå University of Technology, Structural Engineering. ISBN 91-89580-03-6. 228 pp
- Täljsten, B. and Carolin, A (1999): "*Strengthening of a concrete railway bridge in Luleå with carbon fibre reinforced polymers - CFRP: load bearing capacity before and after strengthening*", Technical Report 1999:18, Luleå: Luleå University of Technology, Structural Engineering. 61 pp
- Täljsten, B. and Carolin, A. (2003): "Strengthening two large concrete bridges in Sweden for shear using CFRP laminates", to be presented at *Structural Faults and Repair, -03*, London.
- Täljsten, B. and Elfgren, L. (2000): "Strengthening concrete beams for shear using CFRP-materials: evaluation of different application methods" *Composites Part B: engineering*, pp. 87-96
- Täljsten, B., Abouddrar, A., Burghauser, A. and Carolin, A. (2000): "*Fullskaleförsök på silor förstärkta med kolfiberväv*" Technical Report 2000:13, Luleå: Luleå University of Technology. 64 pp. (In Swedish)
- Täljsten, B., Carolin, A. and Nordin, H. (2003) "CFRP – Strengthening. Concrete Beams Strengthened with Near Surface Mounted CFRP Laminates" Accepted for publication in *Advanced in Structural Eng. – An Int. J.* (Appendix C).
- Vaněk, T. (1986): "Shear strengthening of old concrete beams" *Batim Int Build Res Pract*, V. 14, No. 5, Sep-Oct ISSN 0182-3329, pp. 311-316
- Weijian, Y. and Huiming, H. (2001): "Experimental study on the flexural behavior of RC beams strengthened with CFRP laminates" *International Conference on FRP Composites in Civil Engineering*, Volume 1, J.-G. Teng (Ed). ISBN: 0-08-043945-4 pp 399-405
- Wiberg, A. (2000): "*Strengthening and repair of structural concrete with advanced, cementitious composites*" Licentiate thesis, Stockholm: Royal Institute of Technology 124 pp.
- Xanthakos, P. P. (1996): "*Bridge strengthening and rehabilitation*" Prentice Hall, New Jersey, 966 pp.

## **APPENDIX A – PAPER I**

### **“EXPERIMENTAL STUDY ON STRENGTHENING FOR INCREASED SHEAR BEARING CAPACITY”**

by Anders Carolin<sup>1</sup> and Björn Täljsten<sup>1,2</sup>

<sup>1)</sup> Luleå University of Technology  
Division of Structural Engineering  
SE-971 87 Luleå  
Sweden

<sup>2)</sup> Skanska Teknik AB  
SE-169 83 Solna  
Sweden

Submitted for publication in  
*Journal of composites for construction.*



## EXPERIMENTAL STUDY ON STRENGTHENING FOR INCREASED SHEAR BEARING CAPACITY

by: Anders Carolin<sup>1</sup> and Björn Täljsten<sup>2</sup>

**Abstract:** The need for structural rehabilitation of concrete structures all over the world is well known and a great amount of research is going on in this field. The use of CFRP (Carbon Fiber Reinforced Polymer) plate bonding has been shown to be a competitive method both regarding structural performance and economical aspects. This method refers to the bonding of a thin carbon fiber laminate or sheet to the surface of the structure in order to act as an outer reinforcement layer. However, most of the research has been undertaken to study flexural behavior. This paper deals with shear strengthening of reinforced concrete members by use of CFRP. Test on rectangular beams, 3.5 m to 4.5 m long have been undertaken to study different parameters such as fatigue, anchorage and others. The strain field in shear spans of beams simultaneously subjected to shear and bending is also studied. Presented tests are furthermore a contribution to the existing literature of tests on concrete members strengthened for increased shear capacity.

<sup>1</sup>) Tech Lic. M.Sc., Luleå University of Technology, Luleå, SWEDEN

<sup>2</sup>) Dr. Prof., Skanska Teknik AB, Solna, SWEDEN and  
Luleå University of Technology, Luleå, SWEDEN

Keywords: Concrete, retrofitting, shear, CFRPs, laboratory tests

## INTRODUCTION

All over the world there are structures intended for living and transportation. Some of these structures will need to be replaced since they are in such bad condition. With environmental and economic aspects in mind it is untenable to replace all structures. Instead the structures should be strengthened or retrofitted as far as possible. Strengthening methods are well developed when it concerns flexural strengthening and they have therefore been used quite widely. One method, which has gained acceptance all over the world, is plate bonding with fiber reinforced polymers, FRP, (Burgoyne, 1999; Meier, 1999; Breña et al., 2003 and Wong and Vecchio 2003). The method involves a thin layer of fiber composite being bonded externally to a structures surface where the fibers act as an outer reinforcement. Fiber reinforced polymers have high strength and stiffness to weight ratio, show excellent fatigue behavior, corrosion resistance and are not magnetic. The high number of undertaken projects confirms that the method is here to stay.

Work has been done on many structures to restore or upgrade the flexural capacity while the shear capacity has not been addressed to the same extent, Micelli et al. (2002). When increasing flexure capacity, the structure will be loaded closer to its maximum shear capacity. Täljsten (1994) even shows in a full-scale test that a flexural strengthening can induce a shear failure. On the other hand, a structure with a brittle failure in shear can be strengthened so that the failure mode will change to a more ductile and friendly mode (Collins and Roper, 1990). A beam must have a certain safety margin against shear failure since it is more dangerous and less predictable than flexural failure, (Al-Sulaimani et al., 1994). There exists several methods for strengthening in shear; additional reinforcement covered with shotcrete, claming with steel, just to mention a few. Externally bonding of CFRP is also an effective way to strengthen for increased shear capacity where the bonded fibers become external stirrups, (Pellegrino and Modena 2002; Micelli 2002 and Diagana et al. 2003). CFRP can be bonded in the form of laminates or a composite may be built up on site with fabrics and resin.. Although not the only problem facing structures today, shear deficiencies are becoming more and more prevalent and a great need for strengthening and retrofitting for increased shear capacity exists. Previously research (Carolin, 2001 and Carolin and Täljsten, 2003) have shown that the composite is not uniformly stresses when bonded to the sides of a beam and that this strain field must be further studied to understand the behavior of a member strengthened in shear.

The topic of this paper is strengthening for increased shear capacity of concrete structures. The aims of the study are to investigate the effect of different parameters when upgrading structures for increased shear capacity with externally bonded carbon fiber composites. The strain fields in shear spans of beams simultaneously subjected to shear and bending is also studied. Presented tests with large specimens is furthermore

a contribution to the existing literature of tests on concrete members strengthened for increased shear capacity.

## TRUSS MODEL AND FRP PLATE BONDING

One model to calculate the shear capacity of a reinforced concrete member,  $V_{Rd}$ , is to take the sum of all the terms as shown in Eq. (1), (Täljsten, 2002).

$$V_{Rd} = V_c + V_s + V_f \quad (1)$$

where;  $V_c$  is the concrete contribution, which often includes the dowel action from the tensile reinforcement, and is determined by empirically found relationships,  $V_s$  is the contribution from steel calculated by the truss model, and  $V_f$  is contribution from CFRP strengthening systems. In this study, only the contribution from the strengthening,  $V_f$ , is experimentally investigated. When the contribution from the strengthening is to be calculated it is important to consider the anisotropic behavior of the composite material. From this point on the fiber direction will be defined as the angle between the longitudinal direction of the fibers and the longitudinal direction of the beam. In the following two angles will be used (Fig. 1). The angles are  $\alpha$  for crack inclination, and  $\beta$  for fiber direction.

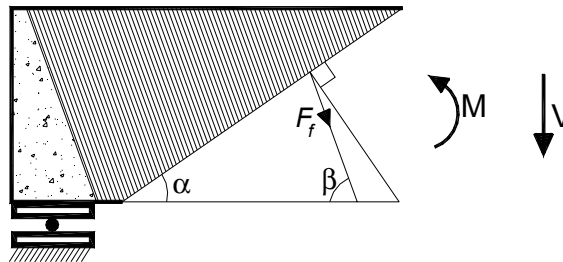

Fig. 1: Fiber alignment and crack angle.

Equations are derived with truss theory as a base and are presented in detail in (Triantafillou, 1998; Täljsten, 2002; Carolin and Täljsten, 2003 and Chen and Teng, 2003). The ultimate fiber fracture strain cannot be used in the same way as the yield strain for steel stirrups because of the non-uniform distribution of shear strains that act on a cross-section, Carolin (2001). Instead, a reduction factor,  $\eta_f$ , must be used that is experimentally studied in this paper and theoretically studied in Carolin and Täljsten (2003).

## SHEAR TESTS

Tests have been undertaken on 23 rectangular reinforced concrete beams. Of these tests, 20 are without steel stirrups (*type A*) and 3 with steel stirrups (*type B*). All beams are heavily reinforced in bending. The first tests to be undertaken were tests with *type A* beams. When it was decided to also study beams with stirrups it was found that *type A* beams would not fail in shear when reinforced with steel stirrups and strengthened in shear. *Type B* beams were then designed to have extra strength in flexure to ensure shear failure even after CFRP strengthening. The fiber direction has been varied as well as the thickness of the fiber sheets used. Some of the beams were pre-cracked before the strengthening was applied. Some beams have been strengthened with fibers on the sides only and others with fibers wrapped around the entire beam, in order to achieve better anchorage. Other beams were subjected to fatigue loading after strengthening had been applied. All beams were finally tested to failure by a deformation controlled loading. Beams have also been reinforced with steel stirrups in one shear span to cause the failure to occur in the other span and therefore make it possible to focus the measurements on the failing shear span. The naming convention for the strengthened beams is described in Fig. 2. The first number denotes fiber thickness 1, 2, and 3 for 125 g/m<sup>2</sup>, 200 g/m<sup>2</sup> and 300 g/m<sup>2</sup> respectively. Then the fiber direction 0°, 45° or 90° comes and finally a letter describing the specimen sort. Non-strengthened reference beams are denoted *R* followed by a number. The beams and their strengthening scheme are presented in Table 1, Fig. 3, and Fig. 4.

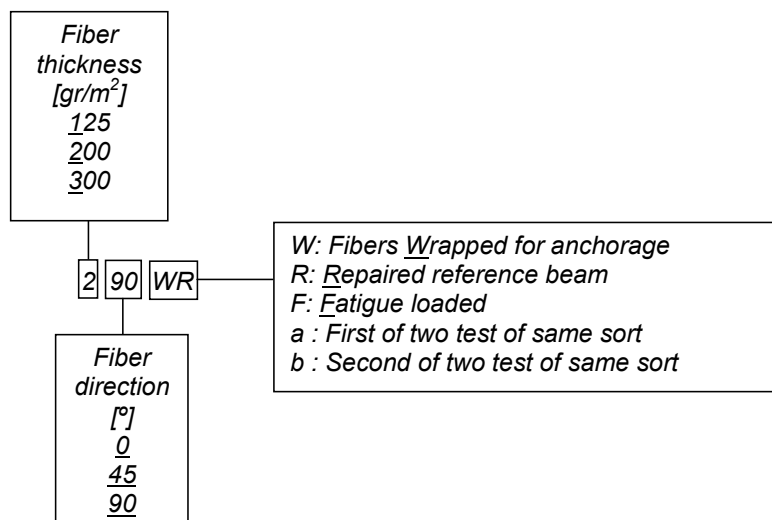

Fig. 2: Naming of strengthened beams



Table 1: Tested beams

<i>Name</i>	<i>Amount [g/m<sup>2</sup>]</i>	<i>Direction [°]</i>	<i>Comments</i>
<u>Type A</u>			
R1	-	-	
R2			
R3			
R4			
R5			
145	125	45	
145F			fatigue loaded
20	200	0	
245a	200	45	
245b			
245W			wrapped
245F			fatigue loaded
245Ra			R2 repaired
245Rb			R3 repaired
245RF			R4 repaired, fatigue loaded
290a	200	90	
290b			
290W			wrapped
290WR			R5 repaired, wrapped
345	300	45	
345F			
<u>Type B</u>			
R	-	-	steel stirrups
290	300	90	steel stirrups
390	300	90	steel stirrups

For strengthening in shear, the system BPE<sup>®</sup> Composites consisting of low viscosity resin (BPE<sup>®</sup> Lim 417) and unidirectional carbon fiber sheets has been used. All beams have been strengthened with the hand lay-up technique in laboratory conditions of 20 °C and 60 % humidity. In Table 2 the properties of the used material are presented. When testing *290W* the mode of failure changed from shear to bending. Therefore *290WR* and *245W* were strengthened in bending with one Sika Carbodur M1412 laminate over the whole length of the tension side of the beam.

Table 2. Material properties

	Compressive strength [MPa]	Tensile strength [MPa]	Young's module [GPa]	Ultimate strain [ $10^{-3}$ ]
Concrete	55 <sup>1)</sup>	3.4 <sup>1)</sup>	42	
Steel	515 <sup>2)</sup>	515 <sup>2)</sup>	210	2.5 <sup>2)</sup>
Adhesive <sup>3)</sup> :				
BPE <sup>®</sup> Lim 417	80	50	2	
BPE <sup>®</sup> Lim 465	103	31	7	
Fiber <sup>3)</sup> :				
BPE <sup>®</sup> Composite S		4500	234	19
Sika Carbodur M1214		>2800	210	>13

- 1) Average
- 2) Yielding
- 3) Suppliers data

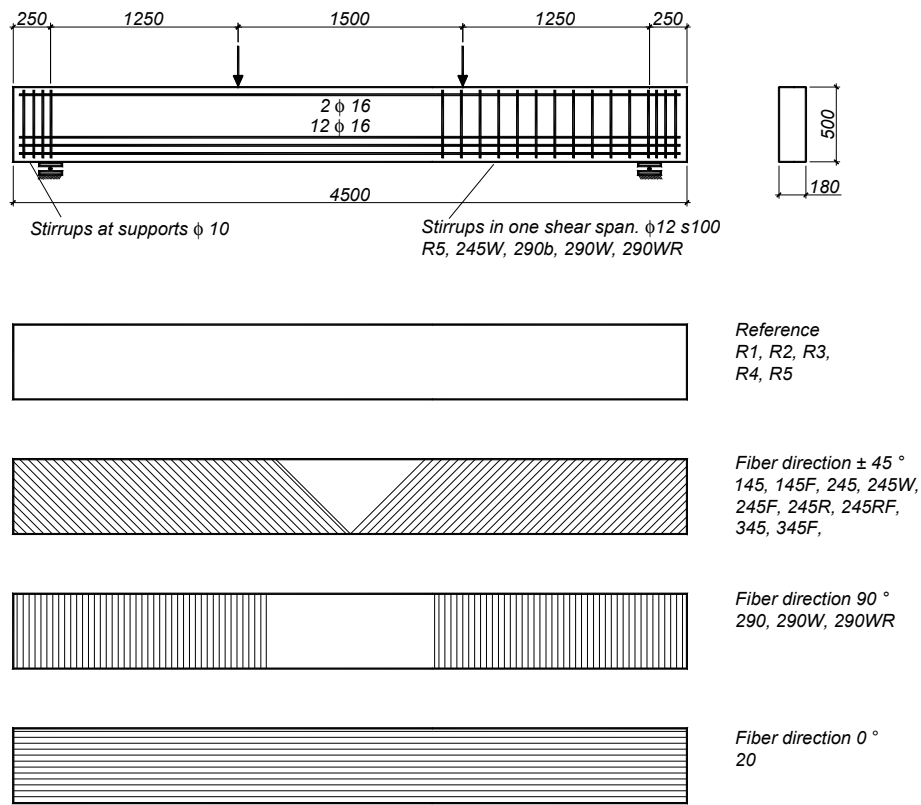

Fig. 3: Strengthening scheme for type A beams.

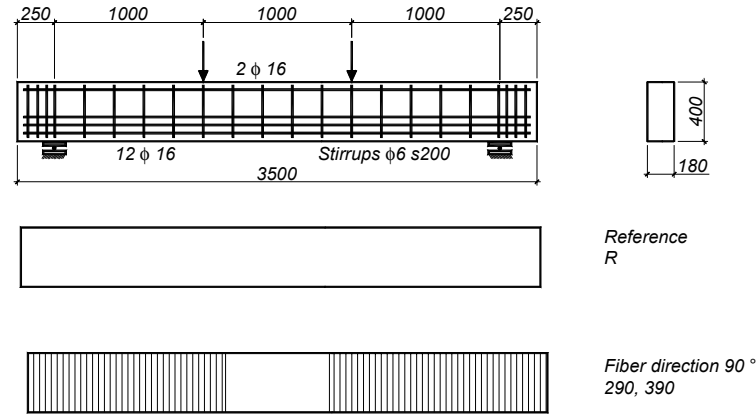

Fig. 4: Strengthening scheme for *type B* beams.

The beams have been subjected to four-point bending as shown in Fig. 3 and Fig. 4. The loading for test to failure was controlled deformation with rates of 0.01 mm/s (0.6 mm/min) for *type A* beams and 0.003 mm/s (0.2 mm/min) for *type B* beams. Beams 145F, 245F, 245RF, and 345F were subjected to  $10^6$  load cycles before loading to failure. The load varied from 40 % to 60 % of the failure load of beams not subjected to fatigue. The fatigue loading was carried out for ten days with a frequency of 1.2 Hz. For all beams load, midpoint deflection and support settlement have been registered. For beams 245W, 290', 290W, and 290WR the strains in the composite have also been registered to measure the strain field. Strain Gauges (SG) and Rosette Strain Gauges (RSG) were placed based on the final failure crack pattern for the other beams on the composite. The placement of the gauges can be seen in Fig. 5. Rosette strain gauges were placed at seven levels of the height of the cross-section, E-K, to measure the strain field in the shear span. Two of the individual gauges of the rosette were placed in the beam's longitudinal, and transverse direction. The third was placed in the 45-degree angle as presented in Fig. 5. To increase the possibility of measuring fiber strains close to the formed final crack, single strain gauges were also placed on the sides of the rosette gauges as presented in Fig. 5. These gauges were placed along the same fiber as the rosette gauge above and below. On the precracked beam 290WR, the rosette gauges were placed along the crack.

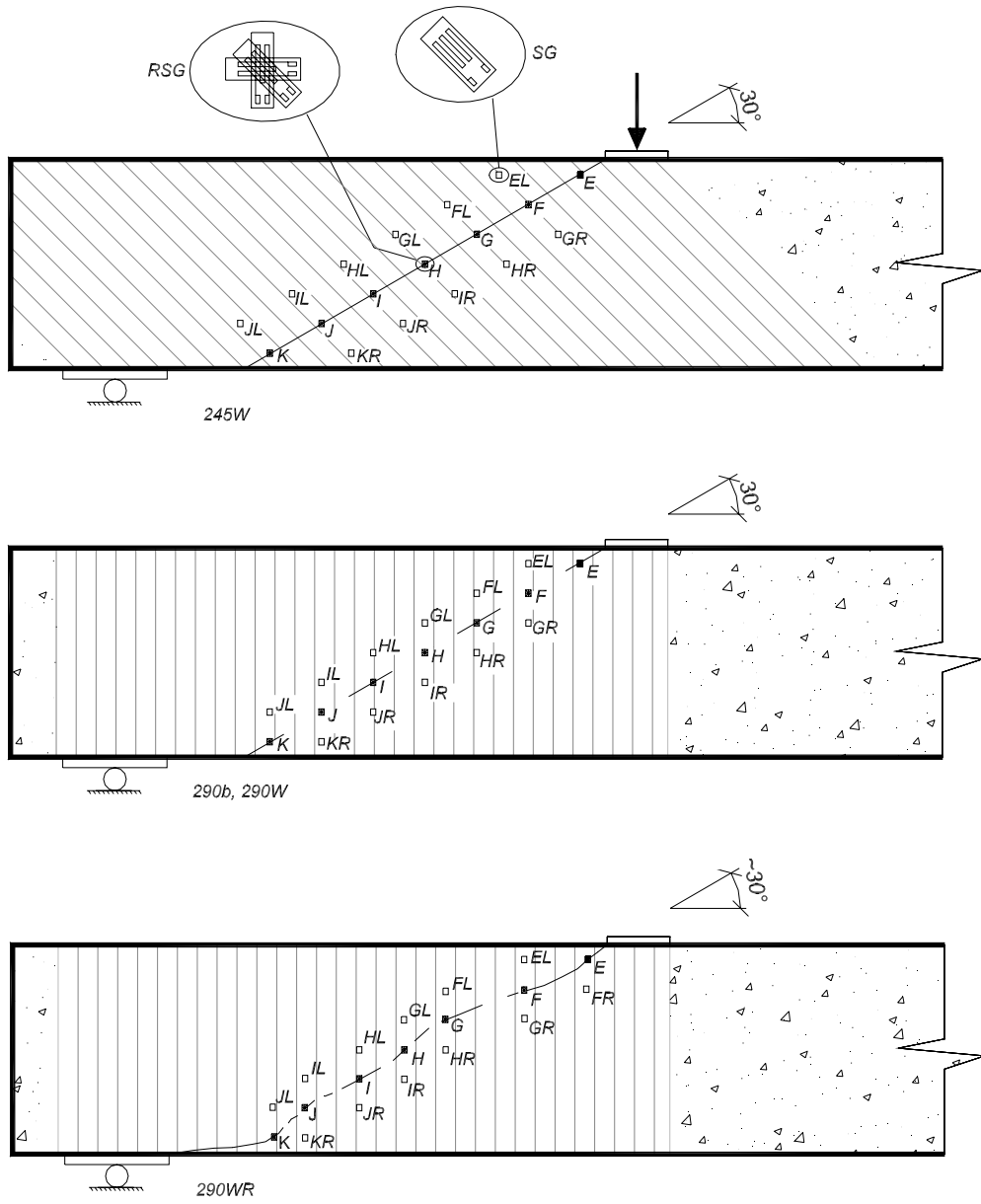

Fig. 5: Points for measurements of strains.

## Results

During loading of the beams to failure, when the load was approximately two thirds or more of the failure load a clicking sound was occasionally emitted from the beams. The occurrence of clicking increased in frequency as the beams were loaded closer to the maximum load bearing capacity. Other than this, no significant warning signals preceded a sudden failure. In Fig. 6 is the identified failure modes shown; “A” for anchorage failure, “C” for compression failure at top of beam, “R” for fiber rupture, “S” Shear crack only in concrete, “AR” for a combination of anchorage failure and fiber rupture at the same load, A+R for fiber rupture after anchorage at a lower load.



*A, Anchorage*



*R, Fiber rupture*

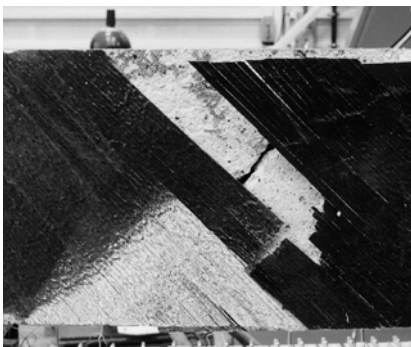

*AR, Anchorage and fiber rupture*

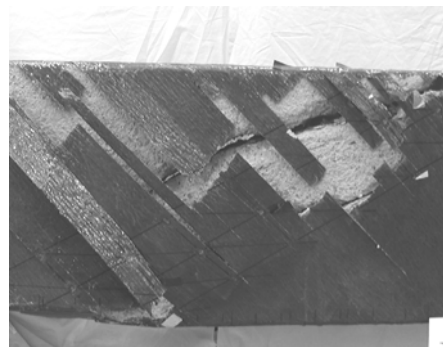

*A+R, Fiber rupture after anchorage failure*

Fig. 6. Failure modes of externally bonded fabrics of carbon fiber

A typical failure crack pattern is shown in (Fig. 7), where the fibers have been manually removed after failure. Before the final shear crack forms, there is a zone of several small shear cracks distributed over the shear span. At failure the final shear crack is then formed by several of these small cracks that are joined together.

Of the total applied load, only half (i.e. reaction force at support) acts as a shear load in each shear span. In the following, all loads presented are the shear loads acting in the shear span. The maximum shear loads from all tests are shown in Table 1 together with concrete capacity tested on 150 mm cubes as an average from three cubes or more and the modes of failure of the beam. The load bearing capacity and the failure modes will be discussed further in the following where different parameters are studied at each time.

Table 1: Maximum shear loads from tests on beams

<i>Beam</i>	<i>Compressive strength [MPa]</i>	<i>Tensile Strength [MPa]</i>	<i>Ultimate shear load [kN]</i>	<i>Failure mode</i>
<u>Type A</u>				
R1	65	3.6	126	S
R2	67	3.5	124*	S
R3	47	3.5	103*	S
R4	53	3.5	119*	S
R5	46	2.9	125*	S
145	67	3.5	247	R
145F	49	3.5	338	R
20	59	3.5	154	S
245a	71	3.8	257	AR
245b	53	3.5	305	AR
245W	46	2.9	338	A+R
245F	49	3.5	319	AR
245Ra	67	3.5	306	AR
245Rb	47	3.5	251	AR
245RF	53	3.5	291	AR
290a	59	3.5	256	A
290b	52	3.7	298	A
290W	52	3.7	367	C
290WR	46	2.9	388	A+R
345	71	3.8	334	A
345F	54	3.6	344	A
<u>Type B</u>				
R	45	2.9	237	C
290	46	3.0	298	A
390	46	2.8	298	A

\*<sup>)</sup> Loading cancelled when shear crack arose.



Fig. 7: Typical failure pattern of strengthened beam, 245W, with CFRP removed.

### Reference beams

When studying shear bearing capacity from a strengthening system the capacity of the original structural element must be known. Therefore several specimens have been tested without strengthening. The results from the tests of the reference *type A* beams are presented in Fig. 8.

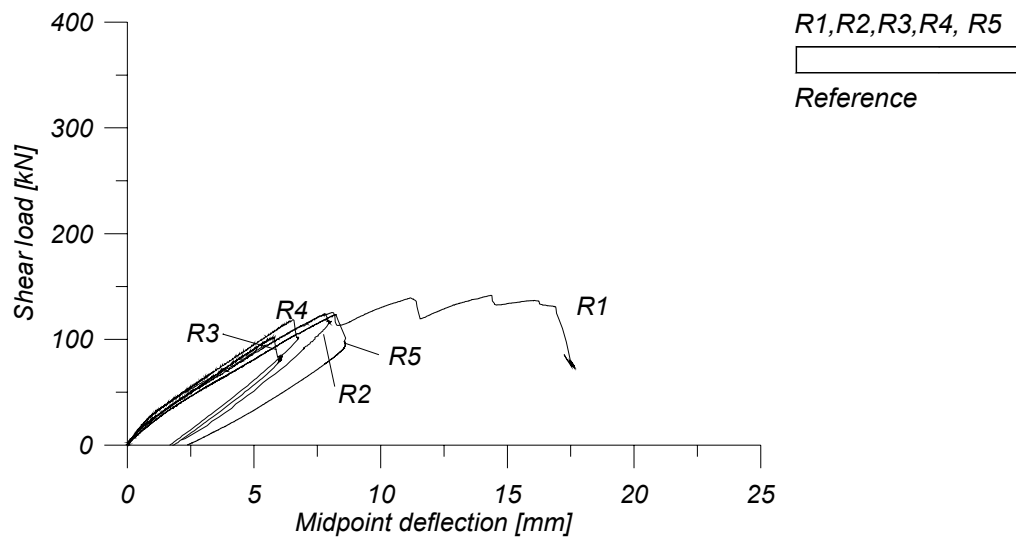

Fig. 8: All reference beams

The loading of beam R2, R3, R4, and R5 was cancelled when a shear crack suddenly arose. This was done because these beams were going to be strengthened after being damaged. However, this can be considered as the ultimate capacity since the

remaining shear capacity only consisted of dowel action from the longitudinal rebars. Beam *R1* was not supposed to be repaired and the loading continued after a shear crack formed. The ductile behavior is due dowel action to the heavily bending reinforcement. There is negligible difference between the reference beams and therefore, in the following figures, only beam *R2* will be used as reference and be called *REF*.

### Fiber direction

Unidirectional carbon fiber composites are highly anisotropic and the effectiveness of strengthening depends to large extent on the fiber direction. The test results from the tests with different alignment of the fibers are summarized in Fig. 9

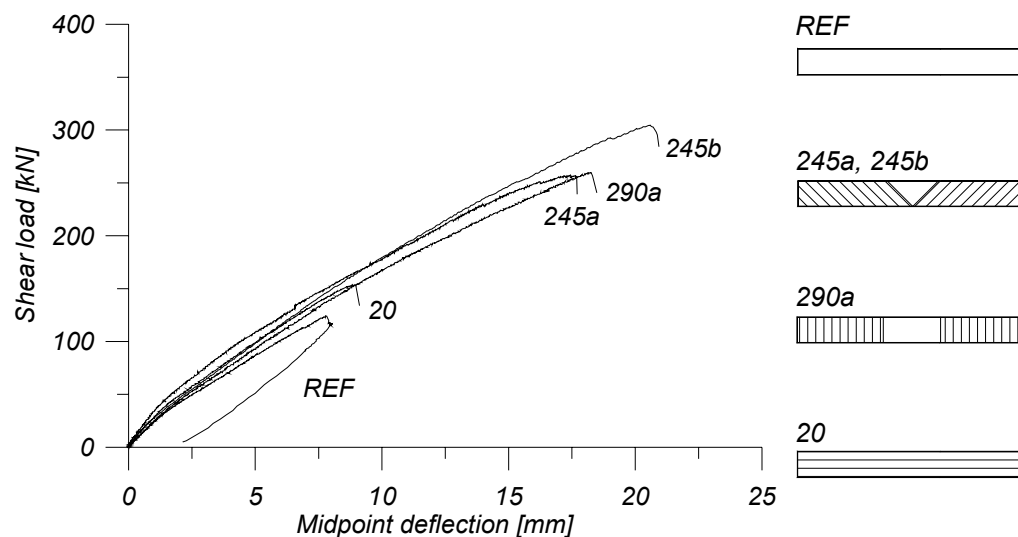

Fig. 9: The effect of different fiber direction

The first thing to be noted is that a significant strengthening effect can be achieved if the fibers are placed in the correct direction in relation to the shear crack. It is also obvious that strengthening scheme 20 ( $0^\circ$ ) did not contribute significantly to the load bearing capacity. The small increase of shear bearing capacity might be due to increased concrete contribution from the distribution of cracks and the crack opening being limited by the longitudinal fibers. The tests showed no difference in bearing capacity between  $45^\circ$  and  $90^\circ$  fiber directions, which is in good agreement with theory presented in (Carolin and Täljsten, 2003). Fibers bonded in a  $90^\circ$  direction debonded at failure. Fibers bonded in  $45^\circ$  direction debonded and ruptured at failure. At failure of beam 20, the fibers had neither ruptured nor debonded.



### Fiber amount

To investigate the influence on shear bearing capacity and failure mode for different amount of bonded fibers, beams have been strengthened with composites with different thickness and amount of fibers. The strengthening effect due to thickness of the composite, i.e. the fiber amount is shown in Fig. 10.

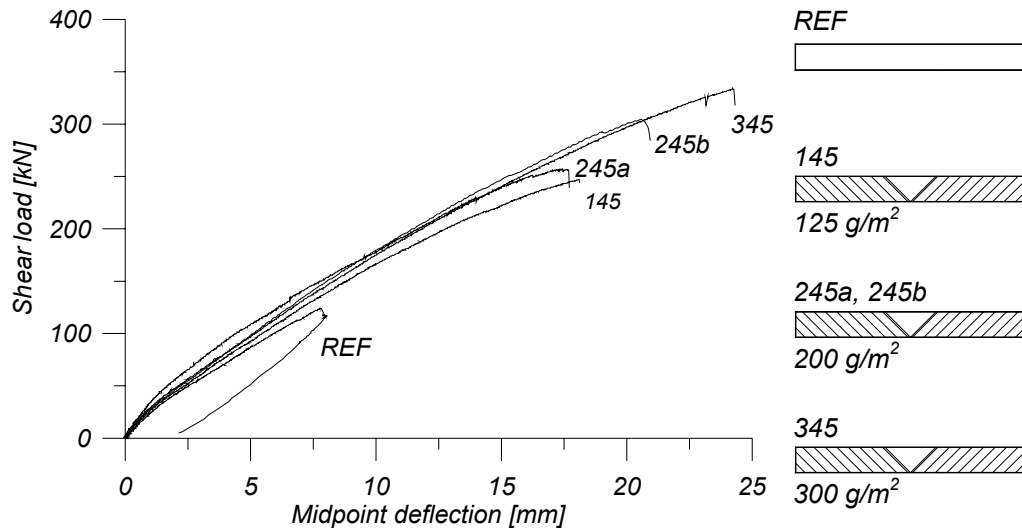

Fig. 10: Results from tests with different composite thickness.

Fig. 10 shows that an increase in fiber amount gives a higher strengthening effect. Final failure of beam 145 ( $125 \text{ g/m}^2$ ) was complete fiber rupture and the load was therefore controlled by the amount of fibers. The “245-beams” ( $200 \text{ g/m}^2$ ) failed finally with a combination of anchorage and fiber failure. It was not possible to determine which failure was the primary one. Final failure of beam 345 ( $300 \text{ g/m}^2$ ) was characterized by complete anchorage failure. The final failure might have been preceded by deformations causing decrease of aggregate interlocking and therefore increase in deformations causing the anchorage failure of the composite, but this cannot be determined from the test.

### Anchorage

As found by the study on fiber amount, the anchorage is of utmost importance. Fibers bonded on sides only may have debonding without reaching the rupture strain. By wrapping the sheets around the entire beam, a good anchorage is obtained. In Fig. 11 load-deflection plots for different anchorage schemes are presented.

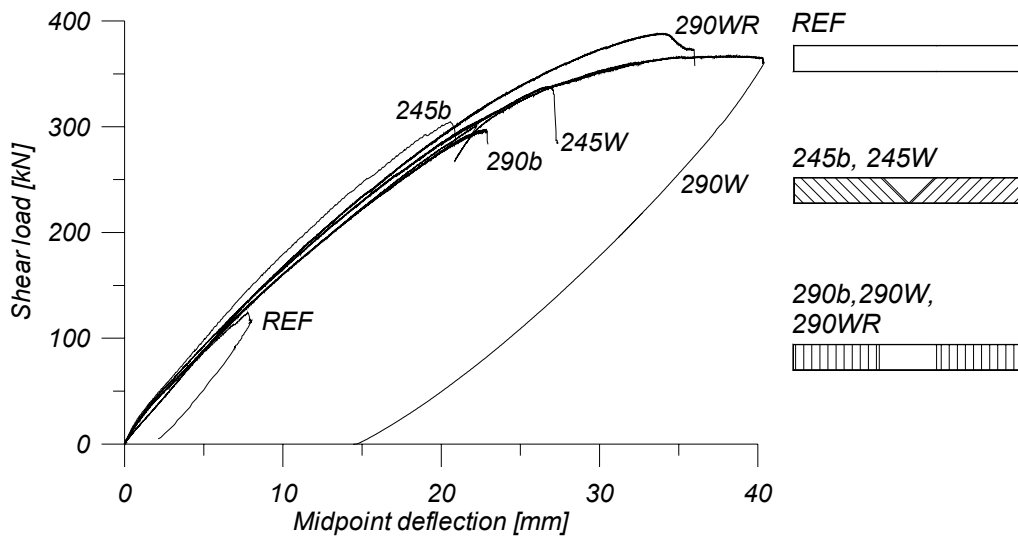

Fig. 11: The effect of different anchorage configurations

As can be clearly seen in Fig. 11 anchoring by wrapping around corners significantly increases the load bearing capacity. The mode of failure actually changed for beam *290W* from shear to bending with yielding of longitudinal steel reinforcement and concrete crushing at the top of the beam. At onset of concrete crushing in bending, the beam was unloaded and inspected. The fibers at this stage had debonded on both sides of the crack zone, but were still attached outside this zone. This may indicate that debonding started from a shear crack in the cracked zone and propagated towards the bottom and top of the beam and is explained by stress concentrations at the crack as schematically shown in Fig. 12.

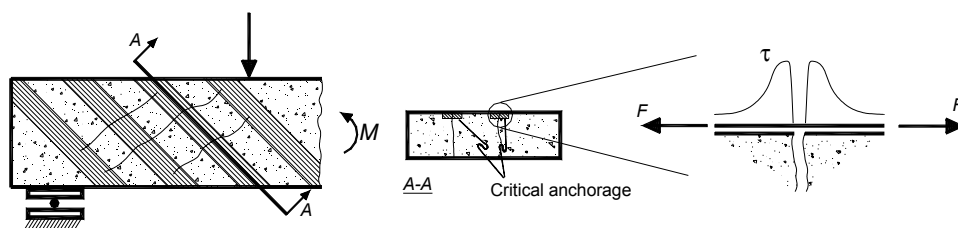

Fig. 12: Bond stresses at crack

The shear stresses become too high at the crack and the anchorage is reduced. Depending on fracture energy of concrete and possibility of strain redistribution the stress concentration is moved outwards from the crack and the anchorage failure propagates or the stress concentration becomes smaller and anchorage is sufficient and

the composite may be loaded further. For a fiber thickness of  $200 \text{ g/m}^2$  shear stress concentration higher than the capacity of the concrete occurs for fiber strains in order of 6000 micro strain.

Beams *245W* and *290WR* were also strengthened in bending, with a high modulus laminate as presented above, to enforce the failure mode to shear. These wrapped beams failed by complete fiber rupture and debonding for all fibers crossed by the final shear crack. The composite debonded prior fiber rupture, however the wrapping gave satisfactory anchorage and the fibers ruptured after additional loading. Beam *290b* failed by debonding, and *245b* by a combination of debonding and fiber rupture.

### Pre-cracking

It is of interest to know whether pre-damaged members may be strengthened to their original capacity or to a higher capacity. In Fig. 13 tests on pre-damaged strengthened beams are presented together with non pre-damaged strengthened beams.

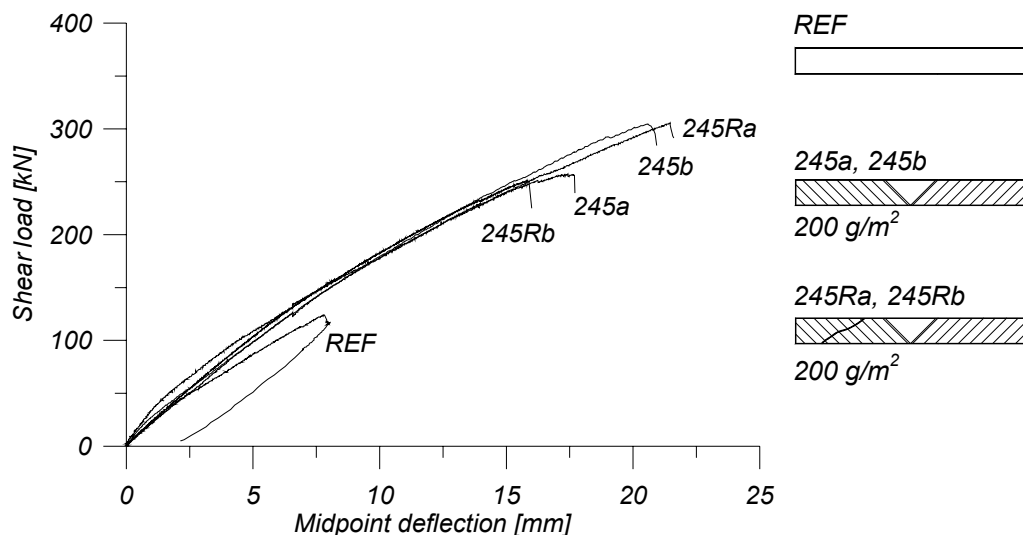

Fig. 13: Pre-cracked and repaired beams

Fig. 13 shows first that a damaged beam can be repaired and strengthened to a level comparable to a strengthened beam that was not damaged before it was strengthened. The repaired beams indicate that there can be a larger difference in load bearing capacity between different repaired beams, but that is not ensured. The distribution between the beams is related to the failure mode. The beams failed in a combination of fiber rupture and debonding. The different ratio of debonding contra fiber fracture gives the different loads.

## Fatigue

Measurements were undertaken during all load cycles. Here only the measurements from loading to failure are presented (Fig. 14). The initial deformation of the beams comes from the fatigue loading that caused flexural cracking. Unfortunately the displacement gauges for beam *145F* were damaged during fatigue loading and therefore no load-deflection plot is presented for this beam. However the *145F* beam was loaded to 338 kN before failure. This is the highest load for all tests of non-wrapped beams and unexpected since it has the lowest amount of fibers. The high capacity cannot be explained other than by a favorable stress distribution together with good anchorage that gives a high fiber utilization, a combination that is not found for any of the other specimens. Therefore, the result is considered exceptional rather than reliable. However, the final failure mode followed the expected pattern. Beam *145F* ( $125 \text{ g/m}^2$ ) failed by fiber fracture, *345F* ( $300 \text{ g/m}^2$ ) by debonding, and *245F* ( $200 \text{ g/m}^2$ ) failed by a combination of the two failure modes.

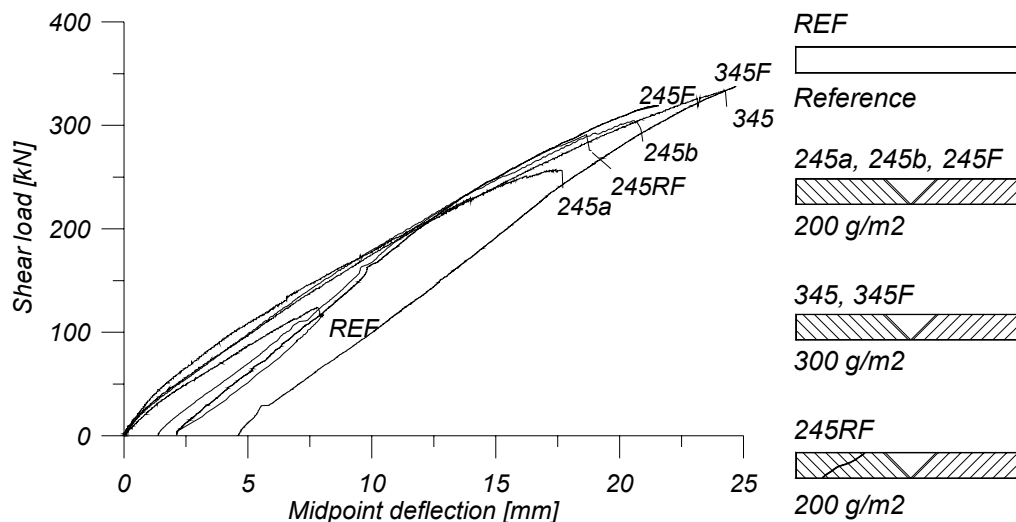

Fig. 14: Fatigue load on strengthened beams

There is a tendency that fatigue loaded beams have a higher load bearing capacity when tested to failure compared to beams without fatigue history. If this is the case, it might be explained by crack distribution that gives a propitious stress situation that in turn gives better anchorage. With only small differences and small amount of tests it is however, not possible to make any conclusion about this. During fatigue loading of beam *245RF* the matrix started to crack. This happened during the first 10 000 cycles and was detected by a color change of the matrix, changing from transparent to a more white frosted color, at location of the crack.

### Tests of beams with steel stirrups

In most cases existing structures have different amounts of steel stirrups. Even if stirrups are not always directly needed for structural reasons, they are sometimes placed in the structure for crack width limitations. Therefore tests are undertaken on beams with stirrups, for both strengthened and non-strengthened beams. The results from these tests, *type B*, with stirrups in the shear span are presented in Fig. 15

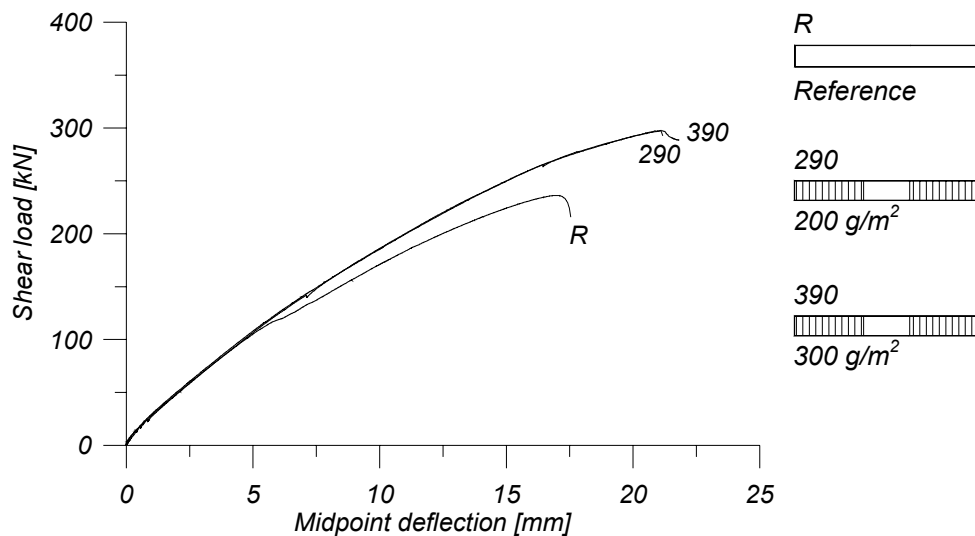

Fig. 15: Load-deflection plots for *type B* beams.

The reference beam was not unloaded at onset of shear cracking. Several shear cracks started to develop in the middle of the height of the beam. As loading continued the cracks grew both in width and length. Finally, the beam failed by a severe shear failure by one large shear crack. The drop in stiffness, for the reference beam at approximately 120 kN, comes from the onset of the formation of shear cracks. This is not found on the strengthened beams since the composite distributes the strains and also holds the cracks together. Both of the strengthened beams failed with complete debonding of the composite. This occurred at the same load for both of the beams. The tests show that concrete beams with stirrups can be strengthened with externally bonded fibers for a higher shear bearing capacity. Beams with stirrups do not have the same lack of shear reinforcement and the strengthening effect can not be as large as for beams without stirrups. If a beam with steel stirrups is in need of a large strengthening effect in shear it is probable that the beam also must be strengthened in flexure. Since the higher amount of fibers in the tests did not give any higher bearing capacity but instead debonded for the same load, it is of utmost importance to anchor the fibers also when beams with stirrups are strengthened.

## Strains

Strains are not only measured to investigate the strain distribution but also to get an understanding on how the composite and concrete will act together and furthermore to measure to what level the composite is stressed. In Fig. 16 the maximum measured strains in fiber direction, at the seven heights (Fig. 5), for beams *245W*, *290W* and *290WR* (all 200 g/m<sup>2</sup>) are presented. On members not pre-cracked, the fibers are not subjected to strains until the load reaches the cracking load for a non-strengthened reference beam, approximately 125 kN. The fibers to be subjected to strains are fibers located at the center of the height of the beam. Fibers bonded in 45 ° direction are subjected to compression forces at the upper part of the beam. Fiber strains measured directly over the crack on the pre-cracked beam, *290WR*, show that the fibers are stressed from the beginning of the test. This was also found from the fatigue loading of beam *145F* that showed a change in color of the matrix just at the location of the shear crack. The color change was due to high cyclic strains in the composite.

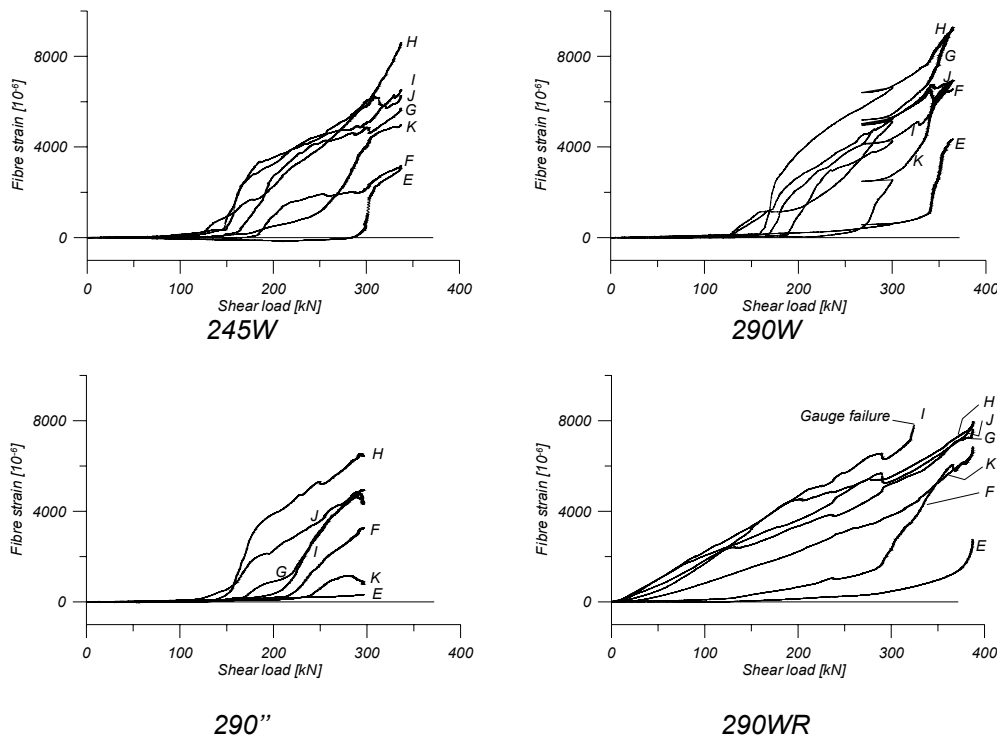

Fig. 16: Maximal measured fiber strains on beam *245W*, *290W* and *290WR*.

The strains presented in Fig. 16 show that for the non-wrapped beam, *290*, the fibers at top (E) and bottom (K) of the beam are hardly stressed at all. The fibers are most stressed at the middle of the beam height (H). For the wrapped beams, debonding takes place at about 300 kN and it is not until then that the upper and lower parts of

the fibers start to be stressed. This becomes more evident if the strains at the different heights are plotted for different loads in the same figure. These strains become strain profiles over the height of the cross-section, i.e. along the crack, and show the strain distributions. In Fig. 17 and Fig. 18 the strain profiles for some chosen loads have been plotted along the length of an idealized final shear crack. The strains have been plotted versus the height of the beam instead of the location on the crack to make comparison possible between non pre-cracked members and pre-cracked member. On the pre-cracked member the gauges have been placed on the same heights but along the real crack instead of the idealized as shown in Fig. 5.

Fig. 17 shows how the strains for 45 ° fiber direction distribute over the cross-section. The fibers start to be stressed when the concrete cracks, and already at 150 kN may the strain distribution be noticed. At 270 kN the non-uniform distribution is obvious, fibers at the upper and lower part of the crack is hardly stressed while the strain in mid-region is about 5000· $\mu\text{s}$  ( $\mu\text{s}$ , micro strain is in text used for  $10^{-6}$  m/m). Actually fibers at the top of the crack are slightly compressed. When the load is further increased the strain becomes more uniform. This is explained by the debonding of the fibers which redistribute the strains. Because of the wrapping the fibers still give a significant contribution even though the fibers are debonded. Just before final failure, 338 kN, the strain distribution is quite uniform, even though the curve seems jagged, with a maximum strain of about 8300  $\mu\text{s}$ . In Fig. 18 the corresponding strains for vertical fibers are shown.

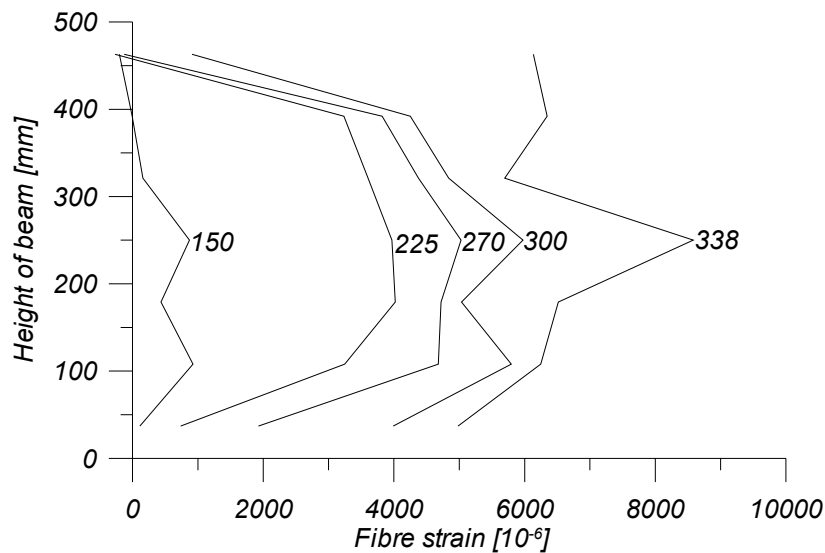

Fig. 17: Fiber strains over cross-section, 245W, 200 g/m<sup>2</sup>.

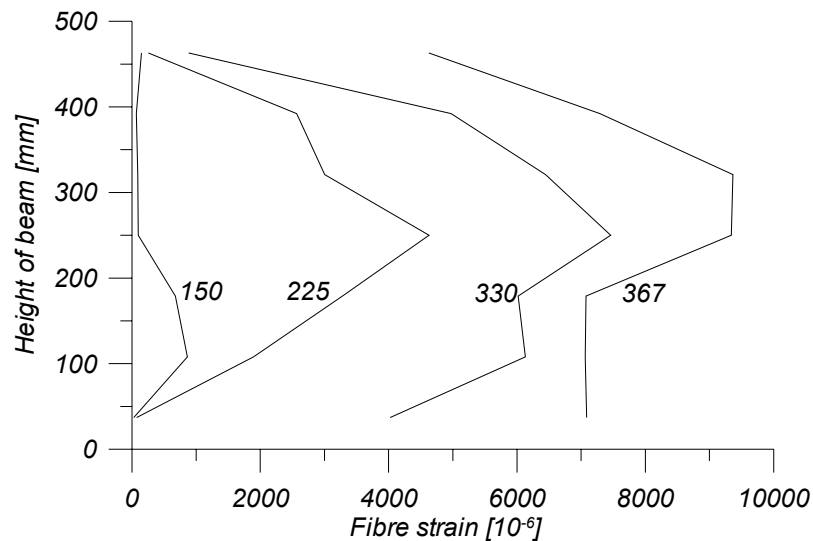

Fig. 18: Fiber strains over cross-section,  $290W$ ,  $200 \text{ g/m}^2$ .

For 225 kN the non-uniform distribution is very distinctive. At 330 kN fibers have started to debond and causing a more uniform distribution. Debonding starts from shear cracks in the cracked zone and propagates outwards as found on beam  $290W$  discussed earlier. Just before final failure, 367 kN, the strain distribution is more uniform with a maximum strain of about  $9200 \cdot \mu\text{s}$ . The measured strains at failure are quite low, compared to  $19\,000 \mu\text{s}$ , the ultimate strain value provided by the supplier. It is natural that the ultimate strain becomes lower for fibers bonded to concrete, defects can be introduced from bonding procedure and stress concentrations can develop at several locations. It is also unlikely that gauges have been placed at the location of the fiber rupture. As been shown, before debonding fibers are differently stressed depending on location on the beam. The measured average fiber strain, compared to measured maximum strain for each beam, before debonding are 0.70 and 0.60 in average for  $45^\circ$  and  $90^\circ$  fiber direction respectively. From Fig. 16 it may be found that the maximum fiber strain when debonding starts at approximately 300kN is in the region of  $6000 \mu\text{s}$ . Beam  $145$ , did not debond but failed by fiber rupture, in this case starting at the center of the beam. After rupture of the first fibers the stresses were redistributed to the other fibers that failed and so on until all fibers had broken.

## CONCLUSIONS

Plate bonding with CFRP is an effective method for increasing the load bearing capacity in shear. A concrete beam may be strengthened so that the failure mode changes from shear to flexure. Due to anisotropy it is of utmost importance to place the fibers in the correct direction in relation to the shear cracks. A damaged beam may be repaired, not only to its original capacity but to a capacity above what it had before.



The strains are not uniformly distributed over the cross-section of a rectangular beam. A reduction factor based upon the strain distribution must be used in designing with the truss model. With satisfactory anchorage such as wrapping, strains can be redistributed which gives a higher load bearing capacity. The distribution of strains is also an issue when designing in service limit state and more research needs to be done. From the tests have different failure modes been identified, fiber rupture, anchorage and combinations thereof. Anchorage is dependent on many factors, for example fiber amount, orientation and quality of workmanship during application of strengthening. Anchorage failure starts from cracks in the shear span and propagates outwards. Anchorage is of utmost importance and should be further studied, especially with the complicated strain field in the concrete in mind. Before failure then shear span have several cracks highly distributed and the final crack is formed by joining of these cracks. Measurements with strain gauges in distinct points are not the optimal recording technique for studying behavior of beams in shear. Strains are highly affected of distance to nearby cracks and gauges in distinct points may give uncertain values. Instead, strain recording techniques covering the whole area, may offer a more complete strain distribution and should be used for detailed studies. The work presented has identified areas in need of more research. Since fibers are active from onset of loading of members with cracks, these members should be studied with loads during strengthening. Finally, the strain field in shear spans and the anchorage situation should be analytically studied. A fracture energy approach should be used in determination of critical anchorage in a zone with shear cracks.

## ACKNOWLEDGEMENT

Lars-Erik Lundbergs Foundation, The Swedish Building and Development Fund, J Gust Richert Foundation, and Skanska AB have provided financial support. For help with the laboratory tests special attention should be given to Håkan Johansson, Lars Åström and Georg Danielsson at Testlab, Luleå University of Technology. The assistance of Professor Lennart Elfgren is also greatly appreciated. Last but not least the students Abderahim Aboudrar, Anders Johansson, Peter Mattsson, Jon Rödsåtre, and Andy Hägglund should be thanked for their energy and collaboration skills during the laboratory work.

## REFERENCES

- Al-Sulaimani, G. J., Sharif, A., Basunbul, I. A., Baluch, M. H. and Ghaleb, B. N. (1994): "Shear Repair for Reinforced Concrete by Fiberglass Plate Bonding", *ACI Structural Journal*, July-August, pp. 458-464
- Breña, S., Bramblett, R., Wood, S. and Kreger, M. (2003): "Increasing Flexural Capacity of Reinforced Concrete Beams Using Carbon Fiber-Reinforced Polymer Composites" *ACI Structural Journal*, Jan-Feb, pp. 36-46.

---

Burgoyne, C. J. (1999): "Advanced Composites in Civil Engineering in Europe" *Structural Engineering International, Journal of the IABSE*, V. 9 No. 4, November pp.267-273.

Carolin, A. (2001): "*Strengthening of concrete structures with CFRP. Shear strengthening and full-scale applications*". Licentiate thesis. Luleå University of Technology, Division of Structural Engineering. 118 pp.

Carolin, A. and Elfgren, L. (2002): "*Load-carrying capacity of concrete structures loaded in shear and torsion – State of the art*" Technical Report 2002:22, Luleå University of Technology. 57 pp.

Carolin, A. and Täljsten, B. (2002): "Behavior of concrete beams strengthened with near surface mounted reinforcement, NSMR", *Proceedings of ACIC2002*, Southampton, April 2002. 9 pp.

Carolin, A. and Täljsten, B. (2003): "Theoretical study on strengthening for increased shear capacity" *Journal of Composites for Construction*. Submitted

Collins, F and Roper, H (1990): "Laboratory Investigation of Shear Repair of Reinforced Concrete Beams Loaded in Flexure" *ACI Materials Journal*, V. 97, No. 2, March-April, pp. 149-159.

Chen and Teng (2003): "Shear capacity of strengthened RC beams: FRP debonding" *Construction and building Material* No. 17 Elsevier. pp 27-41.

Diagana, C., Li, A., Gedalia, B. and Delmas, Y. (2003): "Shear strengthening effectiveness with CFF strips" *Engineering structures* 25 pp 507-516.

Micelli, F., Annaiah, R. and Nanni, A. (2002): "Strengthening of Short Shear Span Reinforced Concrete T Joists with Fiber-Reinforced Plastic Composites" *Journal of composites for construction*, Nov, pp 264-271

Pellegrino, C. and Modena, C. (2002): "Fiber reinforced polymer Shear Strengthening of Reinforced Concrete Beams with Transverse Steel Reinforcement" *Journal of Composites for Construction* May pp104-111

Triantafillou, T. C. (1998): "Shear Strengthening of Reinforced Concrete Beams Using Epoxy-Bonded FRP Composites" *ACI Structural Journal*, V. 95, No. 2, March-April, pp. 107-115

Täljsten, B. (1994): "*Plate bonding, Strengthening of existing concrete structures with epoxy bonded plates of steel or fibre reinforced plastics*" Doctoral Thesis 1994:152 D, Luleå University of Technology. Division of Structural Engineering. August 1994. 290 pp

Täljsten, B. (2002): “*FRP Strengthening of Existing Concrete Structures. Design Guidelines*” Division of Structural Engineering, Luleå University of Technology, Luleå 2002, 228 pp, ISBN 91-89580-03-6.

Wong, R. and Vecchio, F. (2003): “Towards Modeling of Reinforced Concrete Members with Externally Bonded Fiber-Reinforced Polymer Composites” *ACI Structural Journal*, Feb. pp. 47-55



## **APPENDIX B –PAPER II**

“Theoretical Study on Strengthening  
for Increased Shear Bearing Capacity”

by Anders Carolin<sup>1</sup> and Björn Täljsten<sup>1,2</sup>

<sup>1)</sup> Luleå University of Technology  
Division of Structural Engineering  
SE-971 87 Luleå  
Sweden

<sup>2)</sup> Skanska Teknik AB  
SE-169 83 Solna  
Sweden

Submitted for publication in  
*Journal of composites for construction.*



## THEORETICAL STUDY ON STRENGTHENING FOR INCREASED SHEAR BEARING CAPACITY

by Anders Carolin<sup>1</sup>, Björn. Täljsten<sup>2</sup>

### Abstract

In recent years the use of CFRP (Carbon Fiber Reinforced Polymer) for strengthening of concrete has been shown to be a competitive method both regarding structural performance and from economical aspects. The method has been used for almost a decade. Even so, most of the research has been undertaken to study flexural behavior of strengthened structures, and in comparison, the research for shear strengthening has been limited. The work presented in this paper focuses on CFRP strengthening of concrete beams for shear. The theory presented brings up limitations of the widely used truss model, and a refinement is suggested. A reduction factor to consider the non-uniform strain distribution over the cross-section is proposed. Strain limitations are prescribed for the principal strain in concrete instead of fiber strain as earlier models. The derived analytical model is compared to experimental data from tests. Good agreement is found between results from tests and calculated values from theory both regarding shear bearing capacity and average fiber utilization.

<sup>1</sup>) Tech Lic. M.Sc., Luleå University of Technology, Division of Structural Engineering Luleå, SWEDEN

<sup>2</sup>) Dr. Prof. Skanska Teknik AB, Solna, Sweden and Luleå University of Technology, Luleå, SWEDEN

Keywords: shear, concrete, carbon fiber, retrofitting, analytical, truss model, comparison

## INTRODUCTION

There is a large need for strengthening and retrofitting of concrete structures all over the world. The reasons for the need of retrofitting vary, for example; increased demands, design and construction faults, problems initiated by temporary overload, and so on. Some of these insufficient structures will need to be replaced since they are in such bad condition. With environmental and economical aspects in mind it is untenable to replace all structures. Instead the structures should be strengthened or retrofitted as far as possible. A repair and strengthening method that has gained acceptance all over the world is plate bonding with fiber reinforced polymers, FRP, (Burgoyne 1999), (Labossière 2000), (Bencardino et al. 2002), and (Shin and Lee 2003). This method has now been used over a decade and implies that a thin layer of a fiber composite is epoxy bonded externally to a structure's surface and that the composite acts as an outer reinforcement. The composite and the structure act compositely. Carbon fiber reinforced polymers (CFRPs) have high strength and stiffness to weight ratio. CFRP also shows excellent fatigue behavior, corrosion resistance and are not magnetic. It has been found that the method also works in cold climates, (Carolin and Täljsten, 2002) and for strengthening when live loads are acting (Carolin et al., 2003).

The method may be used for increase load bearing capacity in both shear and flexure. Verified and accepted theoretical models are developed when it concerns flexural strengthening. The need for strengthening in flexure has also been dominating and together with a better understanding of the theoretical behavior most strengthening work has been carried out on structures to restore or upgrade their flexural capacity, while the shear capacity has not been addressed to the same extent, (Micelli et al., 2002). Shear deficiencies are becoming more and more prevalent due to several reasons. The design equations that were used when the existing structures were built were much less stringent compared to the codes of today. In Sweden, the allowable shear stress for a typical concrete member has almost been cut in half from 1967 to 1979, (Carolin and Elfgren 2002). Due to the cost of performing full-scale tests, the derived equations for shear have been compared to results from small-scale beams and the effects from scaling have not been completely understood (Reinhardt, 1989). If the flexure capacity is increased, the structure will be loaded closer to its maximum shear capacity. Täljsten (1994), shows in a full-scale test that a flexural strengthening can induce a shear failure. A beam must have a certain safety margin against shear failure since it is more unpredictable and often happens without any forewarning, consequently it is more dangerous than a flexural failure, (Al-Sulaimani et al., 1994 and Täljsten, 2002). On the other hand, a structure with a brittle failure in shear can be strengthened so that the failure mode will change to a more ductile one and consequently give warning before failure, (Carolin and Täljsten, 2003). All of these aspects combined give an increased need for reliable models for design of shear strengthening systems.



The topic of this paper is strengthening for increased shear capacity of concrete structures. Limitations of the widely used truss model are studied. A modified analytical model, which considers the linear elastic behavior and anisotropic nature of the composite, is derived. The model especially shows limitations due to non-uniform strain distribution over the cross-section. The model also addresses issues regarding behavior in the service limit state (SLS) as well as in the ultimate limit state (ULS). Parts of the theories presented in this paper, are already in use in the Swedish guideline for strengthening in shear of concrete structures with FRPs, (Täljsten, 2002). In this paper comparison between tests (Carolin and Täljsten 2003) and the derived theory will be presented together with a thoroughly discussion about the behavior of rectangular RC beams strengthen for shear with CFRP sheets.

## LITERATURE REVIEW

Regions on a rectangular concrete beam where shear cracks typically develop are shown in Fig. 1. Shear cracks will form in the direction that requires the least amount of energy. If the tension forces become too high and the reinforcement is inadequate, the beam will fail by a shear crack, often by yielding in the steel stirrups. If the compression stresses shown in the figure become higher than the compression strength of the concrete, the beam will fail by crushing of the struts. The beam may also fail by a combination of the two failure modes, called the shear-bending failure mode, occurring when a flexure crack joins with a shear crack.

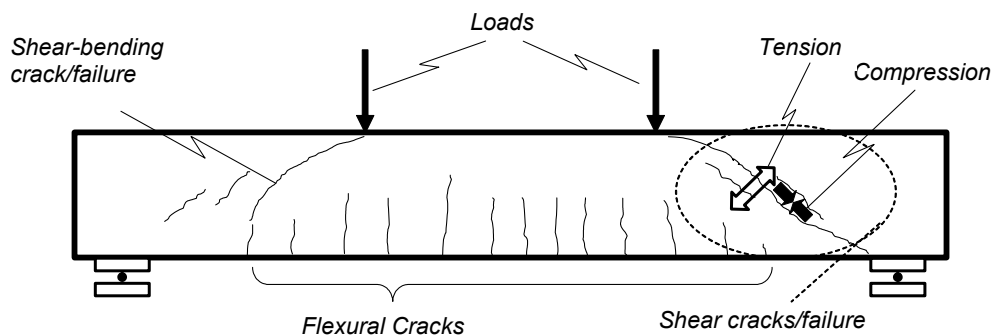

*Fig. 1. Possible shear failure modes for a reinforced concrete beam.*

The two most well known models for predicting the shear capacity of reinforced concrete beams are the truss model by Ritter (1899), and the modified compression field theory by Vecchio and Collins (1986). The focus in this paper will be on the truss model because of ease of use, wide acceptance and the fact that many researchers are using it for predicting the contribution from externally bonded reinforcement.

### Truss Model

The truss model is also known as the strut and tie model and was derived in the end of 19<sup>th</sup> century. Many researchers considered the truss model to give conservative but good results and the model has therefore, regarding steel stirrups, become the basis for many codes such as Eurocode 2, EC 2-1 (2001), the code by ACI (1995) and the Swedish BBK94 (1994). This model assumes that after cracking of the concrete, the behavior of a reinforced concrete beam becomes analogous to that of a truss with a top longitudinal compression cord, a bottom longitudinal tension cord, vertical steel ties and diagonal concrete struts, Fig. 2.

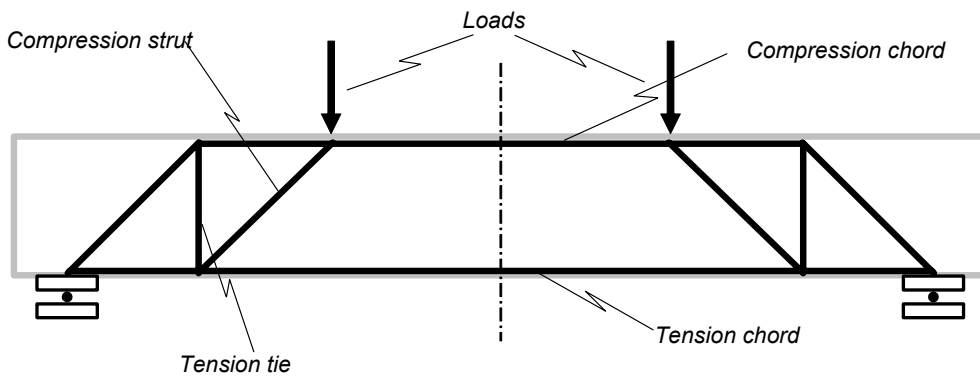

Fig. 2. The truss model with struts and ties

The original truss model assumes that only the steel stirrups carry the tensile forces. When the model is used in many codes, a term is added to the shear capacity to consider what has been called the concrete contribution. The total shear capacity,  $V_{Rd}$ , can be calculated as the sum of all the terms as shown in Eq. (1).

$$V_{Rd} = V_c + V_s + V_p + V_i + V_f \quad (1)$$

where;  $V_c$  is the contribution from the concrete, which often includes the dowel action from longitudinal steel reinforcement, and is determined by empirically found relationships,  $V_s$  is the contribution from steel stirrups calculated by the truss model, and  $V_p$  is the contribution from axial forces, for example pre-stressed cables. Furthermore,  $V_i$  represents other contributions such as inclined compression cords, and  $V_f$  is the contribution from the external bonded composite. The last term will be studied more in detail in this paper. This model of calculating the strengthened structure's capacity is only valid as long as the contribution from concrete is still active. For high strain levels in the shear region the contribution from the concrete decreases as cracks form and widen. The different terms are not necessary at maximum levels for the same deformation and the maximum load bearing capacity

may be for a deformation when the contribution from concrete does not exist. The accuracy of using the superposition principle has been discussed. Eurocode, EC2-1(2001), divides shear elements into members with and without shear reinforcement. The capacity of the concrete can be calculated for members not requiring shear reinforcement. If shear reinforcement is required then the capacity is calculated in accordance with the original truss model without any contribution from the concrete. One of the easier ways to determine the contribution from the concrete is based on the dimensions of the member,  $bd$ , and the formal concrete shear capacity,  $f_v$ , which includes the dowel action from the tensile reinforcement, size effect, and concrete tension capacity, see Eq. (2).

$$V_c = bdf_v \quad (2)$$

The shear capacity of the bending reinforced concrete,  $f_v$ , is empirically determined but is not further discussed here, since there exist several other suggestions on how the concrete capacity may be determined. The contribution from vertical steel stirrups by using the truss theory can be expressed as:

$$V_s = \frac{0.9dA_s f_y}{s_s} \quad (3)$$

where  $A_s$  is the total area of the cross-section of the stirrup (two shears),  $d$  is the effective depth of the beam,  $f_y$  is the yield stress of the steel stirrups and  $s_s$  is vertical center spacing between the stirrups. Eq. (3) is derived for 45 degrees crack inclination and is conservative for smaller angles. The often-assumed crack angle of 45 degrees has been discussed and there exist other assumptions, especially for prestressed concrete. Malek and Saadatmanesh (1998a) presented how the crack inclination angle depends on the amount of shear reinforcement. The truss model with 45-degree cracks is only conservative for normally reinforced beams. With a certain amount of shear reinforcement, the crack inclination angle becomes greater than 45 °. The reason for this is that the crack has to cross less reinforcement for larger crack inclination and this requires less energy in total even though the energy for a shear crack to form in the concrete increases. The truss model does not consider any interaction between torsion, bending and shear. With respect to crack widths, the conditions in the serviceability limit state indicate a need for more reinforcement than in the ultimate limit state.

### ***Existing truss models for plate bonding***

Sato et al. (1996) suggested a model based on the truss model with a reduction factor for the composites based upon distribution of the strain along the shear span. The model was also an attempt to include bond of the composite. Adey et al. (1998) found in experiments that the composite is subjected to a non-uniform strain distribution. The distribution was not further analyzed and to predict shear capacity they used

experimentally determined strain efficiency, based on failure mechanism of composite, i.e. anchorage limitations. Izumo et al (1998) gave empirical equations for estimating the contribution of the fibers to the shear bearing capacity. The equations are based on the truss model and the contribution from fibers is limited by “effective bond area” that can reduce the utilization of the fibers. Challal et al. (1998) give a suggestion based on the truss model where the maximum contribution is limited by a maximum allowable shear strain between composite and concrete. Triantafillou (1998) presented a truss model with limited anchorage. The effective strain in the composite was based on tests. The effective strain depends both on “development” length and axial rigidity of the composite. The effective strain is lower than the ultimate strain of the fibers because of debonding of the composite, concrete failure, stress concentrations due to edges, and local delamination. Khalifa et al. (1998) suggested a modification to Triantafillou’s model where they introduced a strain limitation due to the shear crack width and loss of aggregate interlocking. The effective strain limitation was also refined by considering more tests. The model has been further refined by Khalifa and Nanni (2000), but the basis of the theory remains. Triantafillou (2000) gives also a further refined model, still based on experimental fitting, and with a more palpable distinction between the primary and the final failure mode. ACI Committee 440 (2000) suggests a model for design based on a 45-degree truss. In the model a reduction factor is used for the contribution of the FRP system. To preclude risk for loss of aggregate interlocking in the concrete, a maximum allowed fiber strain of 0.4 % is prescribed. Carolin (2001) and Täljsten (2002) have derived equations based on a truss model for arbitrary angles of fibers and for crack inclination. The equations considered anisotropic behavior of the composite, where the effectiveness of the fibers when placed in a direction that differs from the direction of the principal strain is considered. The model also includes the strain distribution over the cross-section. The model is rather conservative for cases when the contribution from the composite is only limited by the ultimate capacity of the fibers and not principal strains in concrete due to anchorage or concrete contribution. However, as presented in Täljsten (2002) with partial factors, the model is used in the Swedish bridge code. With empirically determined fiber strain and strain distribution the model shows a fairly good agreement with tests. Chen and Teng (2003) propose a model that includes strain limitation due to shortage of anchorage. The model does not consider the non-uniform distribution discussed earlier and presented later in this paper. The model gives quite good agreement for small scale test specimens, but the model is not unit consistent and based on numerical adaptation to tests.

## **REFINED TRUSS MODEL FOR PLATE BONDING WITH CFRP**

In the following a modified truss model will be derived that takes into account strain distribution, the anisotropy of the composite and strain limitations. For shear, the FRP composite may be bonded to the web of the beam throughout its entire length, or it may be bonded in strips with some space between. When the contribution from the strengthening is going to be calculated it is important to also consider the anisotropic

behavior of the composite material used. The composites have their high strength and high stiffness in the fiber direction and are considerably weaker in the perpendicular direction. Since the material is highly anisotropic the consequences can be devastating if the material is placed in the wrong direction and the fibers will affect the performance of the strengthening as described later in this paper. From this point on the fiber direction will be defined as the angle between the longitudinal direction of the fibers and the longitudinal direction of the beam. Equations describing the contribution from a strengthening system do not have to predict the capacity of the concrete or the existing structure. In many cases the capacity of the existing structure is known, at least theoretically, if strengthening is prescribed. Therefore, in the following the expression for the contribution from the strengthening,  $V_f$ , will be determined, which then can be added to the capacity of the existing structure.

**Load bearing capacity**

In the truss model, when used for steel stirrups, it is assumed that all stirrups yield in the ultimate limit state. This is only valid after a certain deformation and is explained by the non-uniform distribution of shear forces that act on a rectangular cross-section, see Fig. 3. These stresses can be projected on a possible shear crack and transformed to maximum principal stresses as shown in Fig. 3.

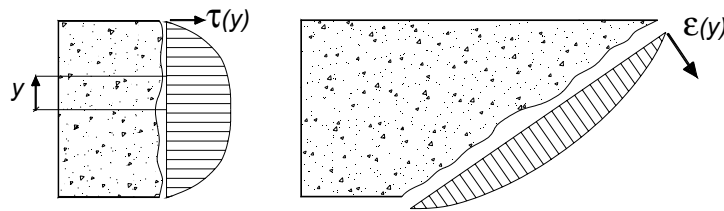

*Fig. 3. Shear strains over a rectangular cross-section and projected and converted to maximum principal strains on a crack, Carolin (2001).*

When steel stirrups are used to reinforce a concrete beam the yielding of steel distributes the stresses over all stirrups crossed by the crack as the deformations increase. When a shear crack forms and widens, the most stressed stirrup starts to yield. If the crack continues to widen, the “neighbor” stirrups reach their yield limit and start to deform and so on until all stirrups in the crack have reached yield. The strains in each stirrup over a crack are schematically shown in Fig. 4.

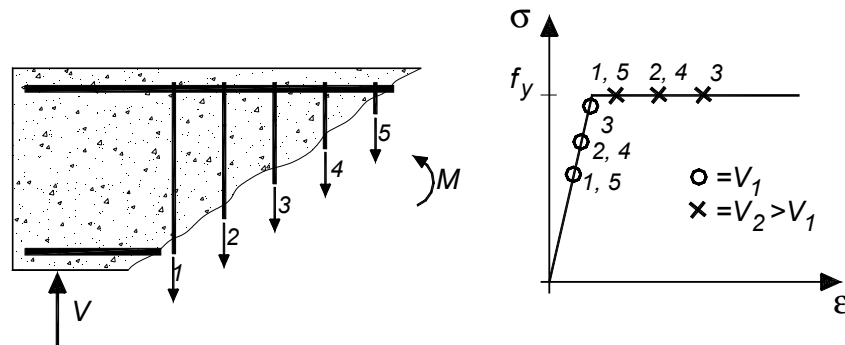

Fig. 4. Principle of work for steel stirrups, Carolin (2001).

This is the reason why the yield stress can be used for all stirrups that are crossed by a crack, when designing in ultimate limit state. In the service limit state (SLS) this is not the case as can be found by studying the stresses indicated with circles in the diagram in Fig. 4. In SLS normally only crack widths and deformation are calculated. However, in SLS, yielding should not take place since it may cause fatigue failure or uncontrolled crack growth.

CFRPs are linear elastic until failure without any distinct yield plateau and will rupture after reaching the maximum load. The non-uniform strain field causes a non-uniform stress field in the composite over the cross-section of the beam, see Fig. 5. The design fiber strain can therefore not be used in the same way as the yield strain for steel stirrups.

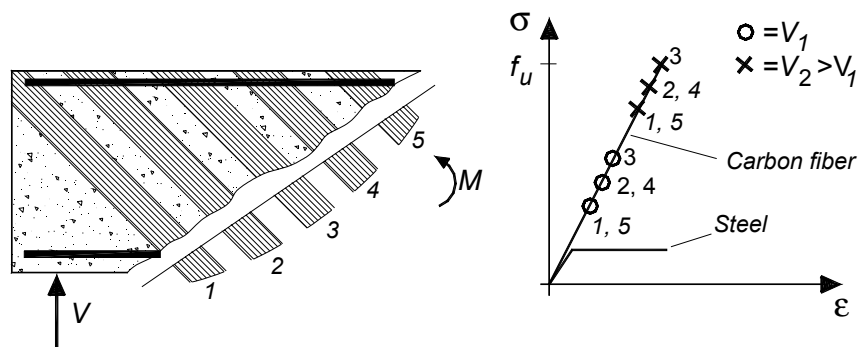

Fig. 5. Stresses and strains over the height of the cross-section, Carolin (2001).

The strain distribution implies that when the most stressed fiber in the center of the beam, Fig. 5, reaches and passes its ultimate capacity then it breaks, forces are redistributed, and the neighbor fibers becomes more stressed and will also rupture. When calculating the contribution from the composite, depending on the location of a

possible crack, the fibers in the composite will be stressed differently. Pure shear is however very unusual in structural members. Most members are simultaneously subjected to both shear force and flexural moment and the loading depends on structural system and type of external loads. By studying the strain field in a concrete member it is possible to predict a possible shear crack. The stress in the composites longitudinal direction,  $\sigma_L$ , depends on the current stress field in every point and the fiber direction  $\beta$ , (Agarwal and Broutman, 1990).

$$\sigma_L = \sigma_x \cos^2 \beta + \sigma_y \sin^2 \beta + 2\tau_{xy} \cos \beta \sin \beta \quad (4)$$

The vertical stress,  $\sigma_y$ , is much smaller than longitudinal stress,  $\sigma_x$ , and the equation can be reduced to

$$\sigma_L = \sigma_x \cos^2 \beta + 2\tau_{xy} \cos \beta \sin \beta \quad (5)$$

where  $\sigma_x$  can be calculated as

$$\sigma_x = -\frac{M_x}{I} y \quad (6)$$

The moment of inertia,  $I$ , needs to be calculated for every cross-section. It will vary with the amount and size of cracks, i.e. loading conditions in every cross-section. However, in regions for high shear stresses the amount of flexural cracking is small. A member critical in shear has satisfactory bending capacity and it is assumed that flexure cracks in the shear critical regions are limited or highly distributed. Before ultimate shear failure the studied shear section does not have any large shear cracks, instead it consists of a cracked zone with many and relatively small cracks spread over the studied area (Carolin and Täljsten, 2003). With the high degree of crack distribution prevailing, the moment of inertia of a non-cracked cross-section is suggested to be used in the equation above. Calculations done with cracked cross-section show that the average fiber utilization, as calculated and presented later, will not vary significantly if it is calculated for a cracked cross-section or a non-cracked cross-section. Furthermore, the shear stresses over a uniform rectangular cross-section subjected to a shear force,  $V$ , can be described as, Popov (1990):

$$\tau_{xy}(y) = -\frac{V}{2I} \left( \frac{h^2}{4} - y^2 \right) \quad (7)$$

Eq. (6) and Eq. (7) in Eq. (5) rewritten gives

$$\sigma_L = \frac{V}{I} \left( y^2 - \frac{h^2}{4} \right) \cos \beta \sin \beta - \frac{M_x}{I} y \cos^2 \beta \quad (8)$$

The shear force over the length of the shear region with distributed load varies. The difference in shear load will not be considered here since the shear strengthening should be designed with uniform shear loads in every studied section. The moment will vary over the length of the assumed crack. With notations as shown in Fig. 6 where  $M_1$  is the flexural moment at the lower end of a possible crack and  $M_2$  is the corresponding moment at the other end of the possible crack, the moment over the assumed crack can be described by Eq. (9).

$$M(y) = \frac{M_1(h-2y) + M_2(h+2y)}{2h} + \frac{qa^2}{8} \left( \frac{4y^2}{h^2} - 1 \right) \quad (9)$$

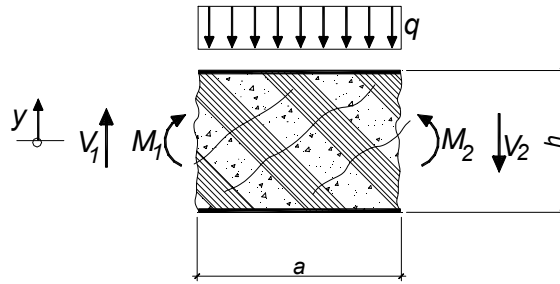

Fig. 6. Definition of bending moments over a cracked zone

Stresses are calculated for all  $y$ , i.e. over the whole cracked zone, by equation 8, transformed into strains, and normalized with respect to the highest tension stress over the cross-section. During transformation and normalization from stresses to strains the material properties for the complex material, reinforced cracked and strengthened concrete, must be considered. The relationship between stresses and strains for this complex material can be modeled in detail but it will depend on amount and direction of cracks, reinforcement ratio, strengthening ratio and direction and every individual material's properties. Here, three rather rough material models will be used and the sensitivity for the final result of strain distribution will analyzed with respect to the material models. First model is based on same stiffness in all directions for both compression and tension and named "1/1/1". This model is not giving a true description of the real material behavior and should instead be seen as one boundary of the material model. The second model is based on that concrete in compression has a stiffness of approximately 30 GPa. Concrete reinforced with 6 % steel bars (only reinforced area studied) with stiffness of 210 GPa subjected to tension has a stiffness of approximately 15 GPa. This value has been calculated based on a 10 % higher stiffness for steel when embedded in concrete compared to bare steel including the



stiffness of concrete in tension (Noghabai, 1998). In the same way, the stiffness of concrete in tension reinforced with stirrups, 1 % steel or externally bonded fibers, is approximately 3 GPa. This gives that concrete in compression is 10 times stiffer and reinforced concrete in tension is 5 times stiffer compared to shear reinforced concrete in tension and the model is named “10/5/1”. The third model is that concrete in compression and tension, i.e. tension but not cracked, is 20 times stiffer compared to shear reinforced concrete in tension and therefore named “20/20/1”. This last model should also be seen as a boundary of the material model. The two last models gives that longitudinal stresses caused by the flexural moment will have less influence on the strains in fiber direction. When strains are going to be calculated from stresses in Eq. (8) the flexural moment is divided by the factor of higher stiffness for each material model presented above. Since the strains are normalized, the absolute stiffness is not necessary to use. With a normalized beam height, the strain profile for 45 ° and 90 ° fiber alignments with end support loading condition and the second material model may be found in Fig. 7. Observe that fibers are subjected to compression when applied in 45 °.

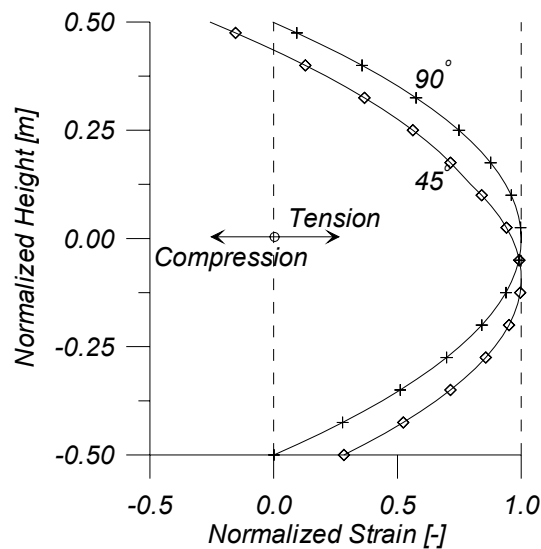

Fig. 7. Fiber strain distribution over the height of a beam for a typical load and two fiber directions.

The normalized strains are integrated over height of the beam and the area is divided with the area for uniform fiber strains (Fig. 8). An average fiber utilization,  $\eta$ , is defined as Eq.(10) where only positive fiber strains are considered. The average fiber utilization expresses the average strain in the fibers over the height compared to the most stressed fiber in the cross-section.

$$\eta = \frac{\int_{-\frac{h}{2}}^{\frac{h}{2}} \varepsilon_f(y) dy}{\varepsilon_{\max} h} \quad (10)$$

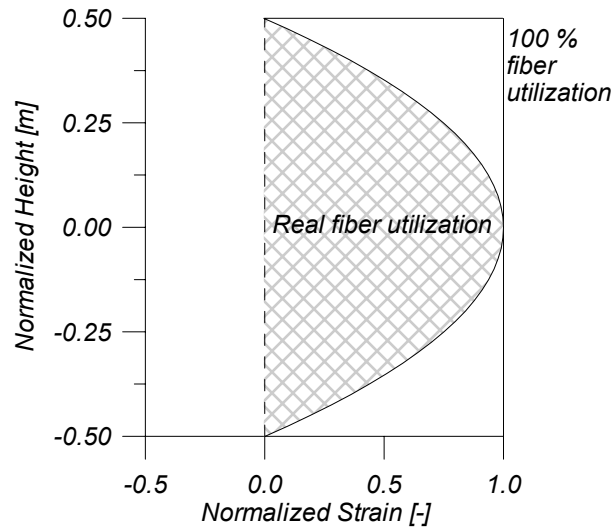

Fig. 8. Fiber strain distribution over the height of a beam for a typical load and two fiber directions.

Composites with stiffness only in fiber direction that are placed vertically are not affected by the bending moment and the fiber utilization is 0.67. For other fiber configurations the situation is different. In Table 1 the effectiveness factors,  $\eta$ , for fiber direction  $45^\circ$  and different flexural moments are listed for the three material models. Moments are normalized to the shear force acting in the studied region and may be calculated by multiplying the listed factors  $m_1$  and  $m_2$  for the moments  $M_1$  and  $M_2$  in Fig. 6. by the shear force  $V$  acting in the studied region. Calculations with moment of inertia for a cracked cross-section give effectiveness factors 0-2 % higher and therefore it is suggested that moment of inertia for non cracked cross-sections are assumed which will be on safe side in all cases. For aligned fibers, bending deformation will decrease the average fiber utilization. The amount and direction of flexural moment depends on both location of the structure and on the structural system. A simply supported beam is subjected to sagging moments in the span and zero moments at the ends, in comparison a two span beam is subjected to large hogging moments at the mid support. Most of the tests in the literature have been conducted on simply supported beams with compression in the upper flange. In many structures with T-beams, i.e. in T-beams that are continuous over supports, the flange is subjected to high hogging moments together with high shear forces.

Table 1: Effectiveness factors for web-bonded fibers

Normalized bending moments $m_1/m_2$ [m]	Fiber direction 45 ° Material parameters			Fiber direction 90 °
	1/1/1	20/20/1	10/5/1	
-2/-1	0.27	0.59	0.52	0.67
-1/0	0.44	0.64	0.62	0.67
0/0	0.67	0.67	0.67	0.67
0/1	0.44	0.64	0.62	0.67
0/2	0.40	0.61	0.57	0.67
0.4/1.25	0.48	0.64	0.64	0.67
1/1	0.36	0.67	0.68	0.67
1/2	0.40	0.64	0.62	0.67
2/3	0.33	0.64	0.56	0.67
-1/1	0.30	0.61	0.56	0.67

Considering the strain field in Fig. 9, where the dashed line indicates flange-web interface, anchorage of the fibers at the top of the upper flange is of utmost importance to achieve good fiber utilization for strengthening of areas at mid supports.

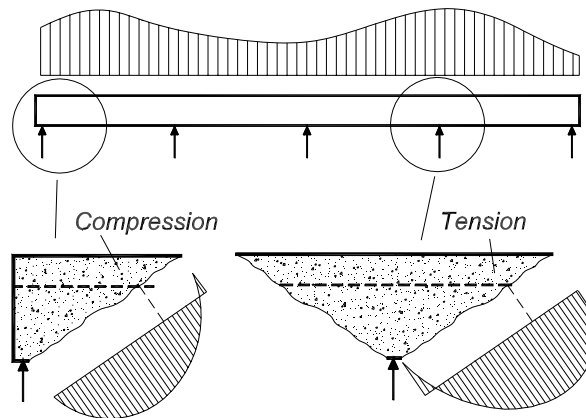

Fig. 9. Strain distribution at end support (left) and mid support (right) for aligned fibers.

Since uni-directional fiber composites are anisotropic the effectiveness of the fibers primarily depends on their orientation (Malek and Saadatmanesh, 1998b and Carolin and Täljsten, 2003). Also the mechanical properties of a composite are anisotropic and dependent of the fiber content. Both laminates and hand lay-ups with unidirectional sheets may be used for strengthening in shear. When hand lay-up is used the fiber content might vary depending on type of structure, used fibers and workmanship. Since fiber stiffness is much higher than the matrix stiffness, the following equations are based on the assumption that the composite only has stiffness in the fiber direction and the stiffness of the matrix is neglected when the shear bearing contribution is

calculated. Derivation of the fiber contribution based on the truss theory requires a definition of an arbitrary path of a possible shear crack. This shear crack is assumed to follow the compression strut in the concrete and to open in the perpendicular direction. Fibers bonded over this possible crack will become stressed by the crack opening and then give a contribution to the shear capacity of the beam. When plate bonding is used for flexural strengthening the direction of the principal stresses may be predict with high accuracy and the fibers can be placed in the most effective direction. However, the direction of the shear cracks is difficult to foresee, and the principal strains and stresses will just in exceptional cases coincide with the fiber direction. Therefore, in the following analysis three angles are needed, see Fig. 10. The angles are  $\alpha$  for crack inclination,  $\beta$  for fiber direction in relation to the beams longitudinal axis, and  $\theta$  for the angle between principal tensile stress and fiber direction, i.e.  $\theta = \alpha + \beta - 90$ .

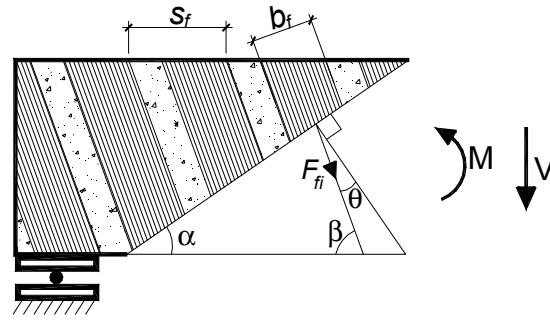

Fig. 10. Fiber alignment and crack angle.

The contribution from the composite,  $V_f$ , can be described as:

$$V_f = F_f \sin(\beta) \quad (11)$$

where:

$$F_f = \sum F_{fi} \quad (12)$$

and  $F_{fi}$  is the force in each composite strip over the assumed crack and is calculated as

$$F_{fi} = \sigma_{fe} A_f \quad (13)$$

In Equation 13 the effective stress,  $\sigma_{fe}$ , can be calculated by Hook's law and a stiffness only in fiber direction:

$$\sigma_{fe} = \varepsilon_{fe} E_f \quad (14)$$

In Equation 14 the effective strain,  $\varepsilon_{fe}$ , can be calculated as:

$$\varepsilon_{fe} = \eta \varepsilon_{cr} \quad (15)$$

The strain reduction factor,  $\eta$ , is dependent on loading condition and fiber orientation as presented earlier in this paper. The critical strain,  $\varepsilon_{cr}$ , is limited by ultimate allowable fiber capacity,  $\varepsilon_{fu}$ , maximum allowable strain without achieving anchor failure,  $\varepsilon_{bond}$ , and maximum allowable strain to achieve concrete contribution,  $\varepsilon_{c\max}$ .

$$\varepsilon_{cr} = \min \left\{ \begin{array}{l} \varepsilon_{fu} \\ \varepsilon_{bond} \cos^2 \theta \\ \varepsilon_{c\max} \cos^2 \theta \end{array} \right\} \quad (16)$$

The reduction  $\cos^2 \theta$  for anchorage and concrete contribution comes from the anisotropic behavior of the composite. The limitation of strain,  $\varepsilon_{bond}$  and  $\varepsilon_{c\max}$ , is defined on maximum principal strain and this will cause a smaller strain in the composite by a factor  $\cos^2 \theta$ . The concrete contribution is dependent on aggregate interlocking (ACI Committe 440, 2000) and since aggregate interlocking is dependent on principal strain or crack opening in principal strain direction the critical strain in fiber direction must be reduced. If sufficient anchorage is secured, by fibers wrapped around corners for instance, then anchorage is not limiting the shear capacity. For smaller amounts of fibers, sufficient bond may nevertheless be achieved without wrapping (Carolin and Täljsten, 2003). The maximum allowed strain with regard to anchorage will therefore depend partially on amount of bonded fibers and fiber stiffness, or axial rigidity as proposed by Triantafillou (1998). It can be discussed whether anchorage limitations should be defined in fiber direction or in direction of maximum principal strain. Anchorage is not further covered within this study. If the contribution from the concrete,  $V_c$ , is not included in the shear bearing capacity, then the limitation  $\varepsilon_{cr} \leq \varepsilon_{c\max} \cos^2 \theta$  can be ignored. Furthermore, depending on what system that is used, the fiber area for one side,  $A_f$ , is calculated by one of the following;

For whole coverage:

$$A_f = t_f z \frac{\cos \theta}{\sin \alpha} \quad (17)$$

and for composite strips:

$$A_f = t_f z \frac{b_f}{s_f \sin \beta} \frac{\cos \theta}{\sin \alpha} \quad (18)$$

where  $z$  is the length of a vertical tension tie in the truss, for steel stirrups normally expressed by the internal lever arm or  $0.9d$ . For composites bonded over the whole height,  $z$  becomes equal to the beam height,  $h$ . For laminates, the thickness,  $t_f$ , for the laminate may be used with the stiffness for the laminate. For hand laid-up sheets with varying fiber content it is more convenient to use a fictive thickness of a plate consisting of homogenous carbon fibers together with the stiffness  $E_f$  for fiber only.

Eq 11 - Eq. 18 gives

$$V_f = \eta \varepsilon_{cr} E_f t_f r_f z \frac{\cos \theta}{\sin \alpha} \quad (19)$$

$$r_f = \begin{cases} \sin \beta & \text{complete coverage} \\ \frac{b_f}{s_f} & \text{composites in strips} \end{cases} \quad (20)$$

The factor  $r_f$  depends on the strengthening scheme and becomes  $r_f = 1$  when the whole side is covered and  $r_f = \frac{b_f}{s_f}$  when composite are applied in strips. The value of  $\eta$  is based on the analysis above suggested to be 0.6.

#### Crack width reduction

If the strengthening is applied to limit crack widths, it is most efficient to bond the fibers perpendicular to the cracks. If the fiber direction differs from the direction of the principal stress by the angle  $\theta$ , the stiffness of the composite must be multiplied by  $\cos^2 \theta$ . More research is needed in the area of service limit state

## COMPARISONS WITH TESTS

In total, 23 beam tests have been undertaken, which all are presented in detail in Carolin and Täljsten (2003). 20 tests have been carried out on beams with dimensions 4500 x 500 x 180 mm<sup>3</sup> with a shear span of 1250 mm without stirrups, *type A*. 3 tests have been done on beams with dimensions 3500 x 400 x 180 mm<sup>3</sup> with a shear span of 1000 mm with 6 mm stirrups at 200 mm spacing, *type B*. The beams are heavily reinforced by steel in bending, by about 4 % steel to concrete ratio. The yield strength of steel was 500 MPa. In Table 2 concrete compression and tensile strength are presented. For strengthening the unidirectional hand lay-up CFRP system BPE<sup>®</sup> Composite S has been used. This system consists of primer, a low-viscosity epoxy resin and fibers with a stiffness of 234 GPa and ultimate elongation of 1.9 %. However, coupon tests on composites have shown that the ultimate strain for the composite is 1.1 % (Svanberg, 1998). Due to irregularities on a concrete surface, difficulties of bonding all fibers straightened and different adhesive thicknesses the ultimate fiber strain becomes lower. Here is 0.9 %, suggested as ultimate fiber strain for the used fibers when they are bonded to a concrete surface. Three thicknesses of the carbon fiber fabrics have been used, 125 g/m<sup>2</sup>, 200 g/m<sup>2</sup>, and 300 g/m<sup>2</sup>, with a thickness for pure homogenous fiber of approximately 0.07 mm, 0.11 mm, respectively 0.17 mm. Fibers have been applied in 45 ° and 90 ° direction both wrapped around and on the vertical sides only, for different beams. For some beams, the strains over the cross-section have been measured as described in Carolin and Täljsten (2003). The naming convention of the beams follows the scheme presented in Fig. 11.

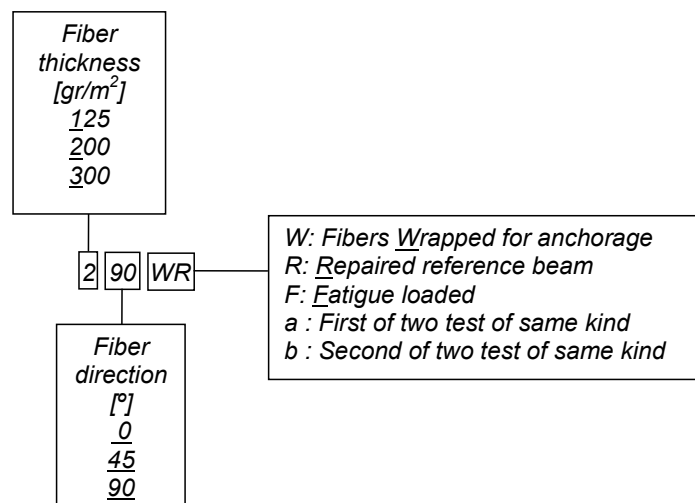

Fig. 11. Naming convention of studied beams

### Strain distribution

For a non pre-cracked beam the fibers are not stressed until the load is above the load that a non-strengthened member can carry. For higher loads the concrete of the strengthened beam starts to crack and the composite becomes active. A pre-cracked and strengthened member behaves somewhat differently and the composite will be stressed from the beginning of loading. To compare the strain distribution derived previously in this paper with the measured strains from the test, the measured strains are normalized with regard to the maximum measured strain over the cross-section. The strains over the height of the beams have are presented in Fig. 12.

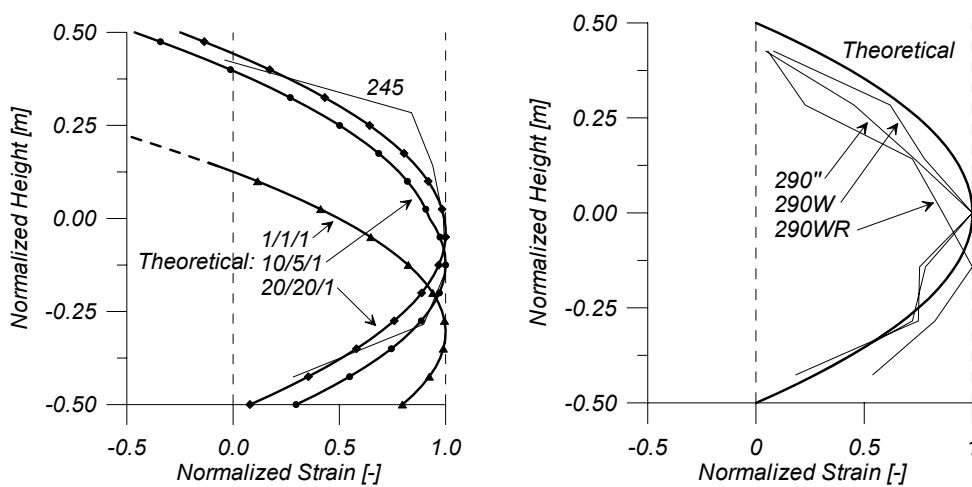
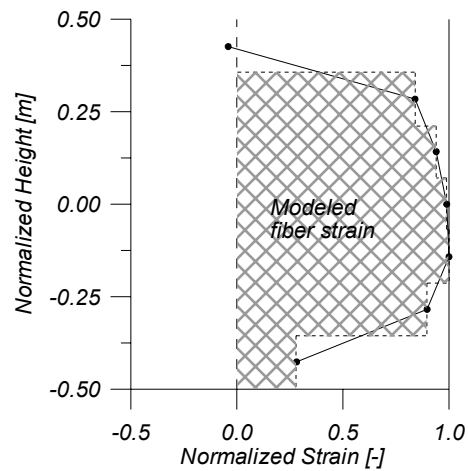

Fig. 12. Strain profiles at 285 kN, fiber directions 45 ° (left) and 90 ° (right)

From Fig. 12 it can be seen that there is a fairly good agreement between strain distribution measured from tests and theoretically calculated strain distribution for material model 10/5/1 and 20/20/1 which gives that the determined average fiber utilization is not sensitive for material model and it is suggested that model 10/5/1 is used. It is interesting to notice that fibers actually are compressed in the upper (compressed) part of the beam when the fibers are applied in a 45 ° direction. The fiber strain distribution is modeled from experimental data as in Fig. 13, where only positive fiber strains are considered. The average fiber utilization from tests is determined in the same way as the theoretical, with the difference that a sum is calculated instead of an integral, and normalized with regard to maximum measured strain. From tests the average fiber utilization was determined to be 0.7 and 0.6 in average for the 45 ° and 90 ° directions respectively. One beam did not fail in shear, 290W, instead the beam was unloaded at onset of concrete crushing in bending (Carolin and Täljsten, 2003).





*Fig. 13. Modeling of fiber utilization.*

Fig. 14 shows one shear span of the beam when the carbon fiber sheets have been manually removed.



*Fig. 14. Crack zone before ultimate shear failure*

Before removal, the fibers were debonded in a zone on both sides of the cracks but not outside this area. This means that debonding starts from the cracks and propagates outwards and that wrapping will not prevent debonding but the composite will contribute considerably even after debonding from the sides. Debonding also gives a more uniform strain distribution, along the shear crack, and therefore the contribution

from fibers becomes higher after debonding has taken place. Whether debonding occurs or not is dependent on many factors, quality of execution of strengthening, fiber amount, concrete quality etc and the increased fiber contribution from a uniform strain distribution is therefore suggested not to be used in design. Fig. 12 also shows that the shear cracking will consist of a severely cracked zone, instead of a large distinct single crack.

### ***Ultimate shear bearing capacity***

Tested reference beams give the contribution from concrete including the effect of dowel action from longitudinal steel rebars. For *type B* beams the reference beam also includes the contribution from the steel stirrups. For *type A* the Reference beams had a shear bearing capacity of 125 kN in average. For *type B* beams the corresponding capacity was 236 kN. The overall shear crack inclinations for all the beams were close to 30 ° for *type A* and 45 ° for *type B* beams and this will be used in the calculations below. With the used test setup this gives the reduction factor for the fibers,  $\eta$ , to 0.66 for fibers in 45 ° and 0.67 for the 90 ° fiber direction. The fibers did not rupture before the concrete contribution was significantly reduced, which is typical. However, it cannot be determined whether anchorage is lost or if the concrete contribution is decreasing at time of failure and therefore is the primary cause of failure. The consequence for non-wrapped beams is that the allowable strains in the composite must be limited, compared to ultimate fiber strain. Here, the maximum strain in the principal direction will be allowed to reach 0.7 %, which is in agreement with the corresponding measured fiber strains from the tests. In comparison, the limitation for aggregate interlocking proposed by ACI of 0.4 % in fiber direction becomes 0.4-0.8 % in principal direction depending on angle between fiber and principal strain. For wrapped members, when the composite debonds, strains are redistributed which gives a uniform strain distribution,  $\eta=1$ , together with ultimate fiber strain of 0.9 % as discussed earlier. At these strains the contribution from the concrete cannot be added to the fiber contribution to the total shear capacity, instead the strengthening material must carry the whole shear force. The concrete is only contributing as compression struts in the assumed truss. Calculated shear capacities are shown in Table 2 together with tested results from Carolin and Täljsten (2003). For the concrete contribution have the tested values from non strengthened beams been used. Tested results are plotted versus theoretically determined capacities in Fig. 15.

From Table 2 it can be found that the tested ultimate failure load varies for the same strengthening configuration. This gives for example a test-theory-ratio of 0.93 and 1.10 for *245a* and *245b* with the higher value for the weaker concrete. In Fig. 15 beams with the same theoretical values have been joined by a line that indicates the difference in tested values for the same strengthening configuration.

Table 2: Shear bearing capacities from tests.

Beam	Concrete capacity compression / tension. [MPa]	Ultimate shear load [kN]	Theoretical shear bearing capacity [kN]	Test/Theory [-]
<u>Type A</u>				
145	67/3.5	247	220	1.12
145F	49/3.5	338	220	1.54
245a	71/3.8	257	277	0.93
245b	53/3.5	305	277	1.10
245W	46/2.9	338	316	1.07
245F	49/3.5	319	277	1.15
245Ra	67/3.5	306	277	1.11
245Rb	47/3.5	251	277	0.91
245RF	53/3.5	291	27	1.05
290a	59/3.5	256	282	0.91
290b	52/3.7	298	282	1.06
290W	52/3.7	>367*	401	>0.91*
290WR	46/2.9	388	401	0.97
345	71/3.8	334	352	0.95
345F	54/3.6	344	352	0.97
<u>Type B</u>				
290	46/3.0	298	296	1.00
390	46/2.8	298	327	0.91

\*) Loading cancelled at concrete crushing in flexure.

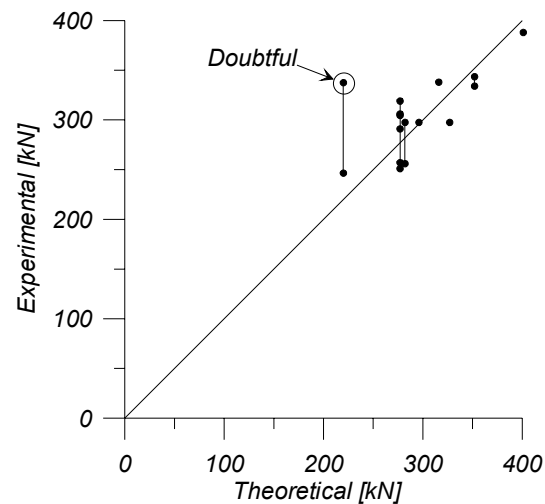

Fig. 15. Tested shear loads plotted versus theoretical capacity.

The high tested capacity of beam *I45F* cannot be explained other than by a favorable stress distribution together with good anchorage that gives a high fiber utilization, a combination that is not found for any of the other specimens. Since the tested capacity of beam *I45F* is 37 % higher than tested capacity of beam *I45*, the result is considered exceptional and doubtful instead of reliable. The comparison between tested values and theoretically predicted values in Fig. 15 shows quite good accuracy of the model. However, some theoretical values are higher than the tested values, which is not desirable in design. With lower values for the allowable principal strain in the concrete, the predicted values become lower than the expected values from tests. If proposed equations are used in design, they should also be used with partial factors, which give further reliability of the bearing capacity.

### **COMMENTS AND FURTHER RESEARCH**

During the work, a number of issues regarding strengthening for increased shear capacity of concrete with externally bonded composites have been identified. The most important will be listed here as a base for further research. In case of applying strengthening in strips, a maximum spacing must be prescribed. Same spacing as for steel stirrups is suggested in order to ensure that a shear crack has to go cross the bonded composite. The maximum allowable concrete strain when concrete still contributes to shear bearing capacity may be dependent on the aggregate size of the concrete and amount of reinforcement and should be further studied. The bond situation and limitation of strain due to anchorage should be further studied and based on a fracture mechanics. Most research has been done on load-bearing capacity in the ultimate limit state. More work and deeper analysis should be done to investigate the strengthening in the service limit state. Methods for estimating crack risks and crack widths ought to be improved. Further, research should be undertaken to investigate the effect from dead loads acting on a structure during strengthening.

### **CONCLUSIONS**

The truss model can be used to satisfactorily describe the contribution from externally bonded carbon fiber polymers. In the truss model, maximum allowable fiber strain is limited by ultimate fiber strain, anchorage of fibers and level of principal strain when contribution from concrete is still active. The ultimate fiber strain in fibers applied to a concrete surface by hand lay-up is lower than the ultimate strain of fibers and ultimate strain determined by coupon tests. In the case where the principal strain in concrete is limiting the allowable strain, difference in principal strain direction and fiber direction must be considered for a consistent limitation of crack opening. Anchorage is of utmost importance and necessary for high fiber utilization. The limitations on strain for anchorage need to be more nuanced, especially with the complicated strain field in mind. Furthermore, a reduction factor for the strain distribution over a cross-section must be considered because of the linear elastic behavior of the fibers. This reduction

factor for rectangular beams is suggested to 0.6 based on laboratory tests and the analytical study presented in this paper.

## ACKNOWLEDGEMENT

Lars-Erik Lundberg's Foundation, The Swedish Building and Development Fund and Skanska AB have provided financial support. For help with the laboratory tests special attention should be given to Håkan Johansson, Lars Åström and Georg Danielsson at TESTLAB, Luleå University of Technology. Last but not least the student Andy Hägglund should be thanked for his never-ending energy working within this project and for fruitful discussions.

## REFERENCES

- ACI 318-85 (1995): "*Building Code Requirements for Structural Concrete*", American Concrete Institute, Farmington Hills, Oct 1995, 369 pp.
- ACI Comitte 440 (2000): "*Guide for the design and construction of externally bonded FRP systems for strengthening concrete structures*". American Concrete Institute, Farmington Hills 24 January 2000.
- Adey, B, de Castro San Román, J. and Brühwiler, E. (1998): "*Carbon fibre shear strengthening of rectangular concrete beams*". Technical Report, Lausanne: École Polytechnique,. 28pp.
- Agarwal B.D., Broutman L.J. (1990): "*Analysis and performance of fiber composites*", 2<sup>nd</sup> edition John Wiley & sons Inc, 449 pp.
- Al-Sulaimani, G. J., Sharif, A., Basunbul, I. A., Baluch, M. H. and Ghaleb, B. N. (1994): "Shear Repair for Reinforced Concrete by Fiberglass Plate Bonding", *ACI Structural Journal*, July-August, pp. 458-464
- BBK 94 (1994): "*Bestämmelser för betongkonstruktioner, BBK 94. Band 1 Konstruktion*", Solna: Svensk Byggtjänst (in Swedish), 185 pp. (ISBN 91-7332-686-0)
- Bencardino, F., Spadea, G. and Swamy, N. (2002): "Strength and Ductility of Reinforced Concrete Beams Externally Reinforced with Carbon Fiber Fabric" *ACI Structural Journal*, Mar-Apr, pp. 163-171.
- Burgoyne, C. J. (1999): "Advanced Composites in Civil Engineering in Europe" Structural Engineering International, *Journal of the IABSE*, V. 9 No. 4, November pp.267-273.

- 
- Carolin, A. (2001): "*Strengthening of concrete structures with CFRP. Shear strengthening and full-scale applications*". Licentiate thesis. Luleå University of Technology, Division of Structural Engineering. 118 pp.
- Carolin, A. and Elfgren, L. (2002): "*Load-carrying capacity of concrete structures loaded in shear and torsion – State of the art*" Technical Report 2002:22, Luleå University of Technology. 57 pp.
- Carolin, A. and Täljsten, B. (2002): "Behavior of concrete beams strengthened with near surface mounted reinforcement, NSMR", *Proceedings of ACIC2002*, Southampton, April 2002. 9 pp.
- Carolin, A. and Täljsten, B. (2003): "Experimental Study on Strengthening for increased Shear Bearing Capacity" *J. of Comp. for Construction*. Submitted
- Carolin, A. Täljsten, B. and Hejll, A. (2003): "Concrete Beams Exposed to Live Loading during CFRP Strengthening" *Journal of Composites for Construction*. Submitted
- Chaallal, O., Nollet, M.-J., and Perraton, D. (1998): "Strengthening of reinforced concrete beams with externally bonded fiber-reinforced-plastic plates: Design guidelines for shear and flexure", *Canadian Journal of Civil Engineering*, pp. 692-704
- Chen and Teng (2003): "*Shear capacity of strengthened RC beams: FRP debonding*" Construction and building Material No. 17 Elsevier. pp 27-41.
- Erki, M.-A. (1999): "Fibre-Reinforced Polymers for Structural Engineering in Canada" Structural Engineering International, *Journal of the IABSE*, V. 9 No. 4, November pp.278-280.
- EC 2-1 (2001): "*Eurocode 2: Design of Concrete Structures – Part 1: General rules and rules for buildings*", prEN 1992-1, CEN (Comité Européen de Normalisation), European Committee for Standardisation, Central Secretariat, Brussels. October 2001. 230 pp
- Izumo, K., Saeki, N., Horiguchi, T. and Shimura, K. (1998): "Study on shear strengthening of RC beams by prestressed fiber sheets", *Transactions of the Japan concrete institute*, V. 20, pp.279-286
- Khalifa, A., Gold, W., Nanni, A. and Abel-Aziz, M. (1998): "Contribution of externally Bonded FRP to the Shear Capacity of RC Flexural Members", *Journal of Composites for Construction*, V. 2, No. 4 pp. 195-202.

Khalifa, A. and Nanni, A. (2000): "Improving shear capacity of existing RC T-section beams using CFRP composites" *Cement & Concrete Composites* No. 22. Elsevier. pp.165-174.

Labossière, P., Neale, K.W., Rochette, P., Demers, M., Lamothe, P., Lapierre, P. and Desgagné, G. (2000) : "Fibre reinforced polymer strengthening of the Sainte-Émélie-de-l'Énergie bridge: design, instrumentation, and field testing" *Can. J. Civ. Eng.* 27. pp 916-927

Malek, A. M., Saadatmanesh, H (1998a): "Ultimate Shear Capacity of Reinforced Concrete Beams Strengthened with Web-Bonded Fiber-Reinforced Plastic Plates" *ACI Structural Journal*, July-August 1998, pp. 391-399.

Malek, A. M., Saadatmanesh, H (1998b): "Analytical Study of Reinforced Concrete Beams Strengthened with Web-Bonded Fiber Reinforced Plastic Plates or Fabrics" *ACI Structural Journal*, May-June 1998, pp. 343-352.

Micelli, F., Annaiah, R. and Nanni, A. (2002): "Strengthening of Short Shear Span Reinforced Concrete T Joists with Fiber-Reinforced Plastic Composites" *Journal of composites for construction*, Nov, pp 264-271

Noghabai, K. (1998): "*Effect of tension Softening on the Performance of Concrete Structures*", Doctoral Thesis 1998:21, Luleå University of Technology, Division of Structural Engineering. 150 pp.

Popov, E. P. (1990): "*Engineering Mechanics of Solids*" New Jersey: Prentice Hall. ISBN 0-13-279258-3. 780 pp.

Reinhardt, H. (1989): "Shear" *Rilem Report, Fracture Mechanics of Concrete Structures* Ed. Elfgren, L. pp 221-237

Ritter, W. (1899): "Die Bauweise Hennebique, Schweizerische Bauzeitung", V. 33 Switzerland

Sato, Y., Ueda, T., Kakuta, Y. and Tanaka, T. (1996) "Shear Reinforcing Effect of Carbon Fiber Sheet Attached to Side of Reinforced Concrete Beams" *Advanced Composite Materials in Bridges and Structures*, El-Badry, M. M., Ed., pp 621-628

Shin, Y.-S., and Lee, C. (2003): "Flexural Behavior of Reinforced Concrete Beams Strengthened with Carbon Fiber-Reinforced Polymer Laminates at different Levels of Sustaining Load." *ACI Structural Journal* Mar-Apr, pp.231-239

Svanberg, M. (1998): "*Materialdata för kolfiberlaminat*" (Material data for carbon fiber laminates, In Swedish) Report, Sicomp, December.

Triantafillou, T. C. (1998): "Shear Strengthening of Reinforced Concrete Beams Using Epoxy-Bonded FRP Composites" *ACI Structural Journal*, V. 95, No. 2, March-April, pp. 107-115

Triantafillou, T. and Antonopoulos, C. (2000): " Design of Concrete Flexural Members Strengthened in Shear with FRP", *Journal of Composites for Construction*, Nov, pp 198-205.

Täljsten, B. (1994): "*Plate bonding, Strengthening of existing concrete structures with epoxy bonded plates of steel or fibre reinforced plastics*" Doctoral Thesis 1994:152 D, Luleå University of Technology. Division of Structural Engineering. August 1994. 290 pp

Täljsten, B. (2002): "*FRP Strengthening of Existing Concrete Structures. Design Guidelines*" Division of Structural Engineering, Luleå University of Technology, Luleå 2002, 228 pp, ISBN 91-89580-03-6.

Vecchio, F. J., and Collins, M. P. (1986): "The modified compression Field Theory for Reinforced Concrete Element Subjected to Shear" *ACI Structural Journal*, V.83, No. 2, 1986, pp. 219-231



## **APPENDIX C – PAPER III**

“Concrete structures strengthened with  
Near Surface Mounted Reinforcement of CFRP”

by Björn Täljsten<sup>1,2</sup>, Anders Carolin<sup>1</sup> and Håkan Nordin<sup>1</sup>

<sup>1)</sup> Luleå University of Technology  
Division of Structural Engineering  
SE-971 87 Luleå  
Sweden

<sup>2)</sup> Skanska Teknik AB  
SE-169 83 Solna  
Sweden

Accepted for publication in

*Advances in Structural Engineering – An International Journal*



# **CONCRETE STRUCTURES STRENGTHENED WITH NEAR SURFACE MOUNTED REINFORCEMENT OF CFRP**

Björn Täljsten<sup>1</sup>, Anders Carolin and Håkan  
Nordin

Division of Structural Engineering, Department  
of Civil Engineering  
Luleå University of Technology,  
SE-971 87 Luleå, SWEDEN

## **1. ABSTRACT**

The need of maintenance, repair and upgrading of concrete structures has increased considerably over the last decade and will most likely continue to do so. There can be several reasons for this, but it can often be attributed to normal change of use, increased demands on the structure, errors in the design and/or construction phase or in the worst case, accidents. Different methods have been developed over the years for solving different rehabilitation problems. Recently, advanced composites used for external bonding in the form of fabrics or laminates have become an accepted method. Several thousands of objects around the world have been upgraded with advanced composites bonded to its surface. In most cases, this method is very competitive regarding both structural behaviour and economy, but there are also some drawbacks. The surface bonded composite material is relatively sensitive to fire, accidents or vandalism. In addition, the pre-treatment is relatively intensive and time consuming. However, if the composite material is placed in slots in the concrete cover some of these drawbacks can be overcome. This paper presents work carried out on near surface mounted reinforcement (NSMR) at Luleå University of Technology in Sweden.

---

<sup>1</sup> email: bjorn.taljsten@ce.luth.se, phone: +46 70 537 43 70, fax: +46 920 49 19 13

## **KEYWORDS**

NSMR, CFRP, concrete, strengthening, epoxy, composite, pre-stressing

## **2. INTRODUCTION**

Concrete is a building material with a high compressive strength and a poor tensile strength. A structure without any form of reinforcement will crack and fail when subjected to a relatively small load. The failure occurs in most cases suddenly and in a brittle manner. To increase a structure load carrying capacity and ductility it needs to be reinforced. This is mostly done by reinforcing with steel bars that are placed in the structure before the concrete is cast. Since a concrete structure usually has a very long life the demands on the structure will normally change over time. The structures may have to carry larger loads at a later date or meet new standards. In extreme cases, a structure may need to be repaired due to accidents. Another reason includes errors made during the design or construction phase so that the structure needs to be strengthened before it can be used. It should also be remembered that over the past decade, the issue of deteriorating infrastructure has become a topic of critical importance in Europe, and to an equal extent in the United States and Japan. For example, the deterioration of decks, superstructure elements and columns of bridges can be traced to reasons ranging from ageing and environmentally induced degradation to poor initial construction and lack of maintenance. As an overall result, a significant portion of our infrastructure is currently either structurally or functionally deficient. Beyond the costs and visible consequences associated with continuous retrofit and repair of such structural components are the real consequences related to losses in production and overall economies related to time and resources caused by delays and detours. As we move into the twenty-first century, the renewal of our lifelines becomes a critical issue. To keep a structure at the same performance level it needs to be maintained at predestined time intervals. If lack of maintenance has lowered the performance level of the structure, need for repair up to the original performance level may be required. In cases when higher performance levels are needed, upgrading can be necessary. Performance level means load carrying capacity, durability, function or aesthetic appearance. Upgrading refers to strengthening, increased durability, and change of function or improved aesthetic appearance. In this paper, mainly strengthening is discussed.

Maintenance, repair and strengthening of old concrete structures are becoming increasingly common. If one considers the capital that has been invested in existing infrastructures, then it is not always economically viable to replace an existing structure with a new one. The challenge must be taken to develop relatively simple measures to keep or increase a structure performance level through its life. This places a great demand on both consultants and contractors. There are difficulties in identifying the most suitable method for an

actual subject; for example, two identical columns within the same structure can have totally different life spans depending on their individual microclimate. Because of this, it is important to analyse the problem thoroughly to be able to select the most suitable method. The choice of an inappropriate repair or strengthening method can even worsen the structure's function. In comparison to building a new structure, strengthening an existing one is often more complicated since the structural conditions are already set. In addition, it is not always easy to reach the areas that need to be strengthened, often there is also limited space. Traditional methods such as different kinds of reinforced overlays, shotcrete or post tensioned cables placed on the outside of the structure normally need much space.

In recent years the development of the plate bonding repair technique has been shown to be applicable to many existing strengthening problems in the building industry. This technique may be defined as one in which composite sheets or plates of relatively small thickness are bonded with an epoxy adhesive to, in most cases, a concrete structure to improve its structural behaviour and strength. The sheets or plates do not require much space and give a composite action between the adherents. The adhesive that is used to bond the fabric or the laminate to the concrete surface is a two-component epoxy adhesive. The old structure and the new bonded-on material create a new structural element that has a higher strength and stiffness than the original. The basic ideas related to the use of FRPs (Fibre Reinforced Polymers) for structural strengthening, along with examples of application, have been presented by (Triantafillou, 1998). The past and potential future use of FRP strengthening and rehabilitation have also recently been documented in many conference proceedings (Meier and Betti, 1997; Benmokrane and Rahman, 1998; keynote lectures (Maruyama, 1997; Neale and Labossière, 1997) and journal articles (Täljsten, 1997, Thomas, 1998). There are also tests reported where NSMR rods were used (De Lorenzis et al, 2000, Blaschko, 2001, Rizkalla and Hassan, 2001 and Nanni, 2001). In spite of the research carried out no one has earlier reported tests on pre-stressed NSMR. The most common way to strengthen structures has been for flexural strengthening and confinement but shear strengthening is also often needed. The most common method is to place sheets or laminates on the surface of the structure, however, further development of the plate bonding method has shown that it is favourable to place the laminates in the concrete cover of the structure. This method can be designated Near Surface Mounted Reinforcement (NSMR).

### 3. NSMR - A SHORT INTRODUCTION

The use of Near Surface Mounted Reinforcement for concrete structures is not a new invention. A type of NSMR has been used since the 1940s, where steel reinforcement is placed in slots in the concrete cover or in additional concrete cover that is cast onto the structure (Asplund, 1949). Here steel bars are placed in slots in the concrete structure and then the slots are grouted. It has also been quite common to use steel bars, fastened to the outside of the structure, covered with shotcrete. However, in these applications it is often difficult to get a good bond to the original structure, and in some cases, it is not always easy to cast the concrete around the whole steel reinforcing bars. From the 1960s the development of strong adhesives, such as epoxies, for the construction industry moved the method further ahead by bonding the steel bars in sawed slots in the concrete cover. However, due to the corrosion sensitivity of steel bars an additional concrete cover is still needed. For these applications, epoxy coated steel bars have also been used. However, it has been shown that over time, epoxy coated steel bars are not always corrosion resistant for various reasons that will not be discussed here. The use of steel NSMR cannot be said to have shown great success. Nevertheless, by using CFRP NSMR some of these drawbacks that steel NSMR possess can be overcome.

Firstly, CFRP NSMR does not corrode, so thick concrete covers are not needed. Secondly, the CFRP laminate can be tailor-made for near surface applications and moreover, the lightweight of the CFRP laminates makes them easy to mount. Finally, depending on the form of the laminate air voids behind the laminates can be avoided. Both epoxies and systems using high quality cement mortar can be used. However, before proceeding, a short description of how to undertake a strengthening work with NSMR will be given. In practical execution the following steps must in general be performed during strengthening:

- Sawing slots in the concrete cover, with the depth depending on the product used and the depth of concrete cover.
- Careful cleaning of the slots after sawing using high-pressurised water, approximately; 100 - 150 bars is recommended. No saw mud is allowed in the slot.
- If an epoxy system is used, the slot must be dry before bonding. If a cement system is used it is generally recommended that the existing surfaces are wet at the time of concrete mortar casting.
- Adhesive is applied in the slot, or with a cement system, cement mortar is applied in the slot.

Table 1. Characteristics and aspects of externally bonded FRP reinforcement

	<b>Laminates</b>	<b>Sheets</b>	<b>NSMR</b>
Shape	Rectangular strips	Thin unidirectional or bi-directional fabrics	Rectangular strips or laminates
Dimension: thickness width	Ca: 1.0 - 2.0 mm Ca: 50 - 150 mm	Ca: 0.1 - 0.5 mm Ca: 200 - 600 mm	Ca: 1.0 - 10.0 mm Ca: 10 - 30 mm
Use	Simple bonding of factory-made profiles with adhesives	Bonding and impregnation of the dry fibre with resin and curing at site	Simple bonding of factory made profiles with adhesive or cement mortar in pre-sawed slots in the concrete cover
Application aspects	<p>For flat surfaces</p> <p>Thixotropic adhesive for bonding</p> <p>Not more than one layer recommended</p> <p>Stiffness of laminate and use of thixotropic adhesive allow for certain surface unevenness</p> <p>Simple in use</p> <p>Quality guaranteed from factory</p> <p>Suitable for strengthening in bending</p> <p>Needs to be protected against fire</p>	<p>Easy to apply on curved surfaces</p> <p>Low viscosity resin form bonding and impregnation</p> <p>Multiple layers can be used, more than 10 possible.</p> <p>Unevenness needs to be levelled out</p> <p>Need well documented quality systems</p> <p>Can easily be combined with finishing systems, such as plaster and paint</p> <p>Suitable for shear and bending strengthening</p> <p>Needs to be protected against fire</p>	<p>For flat surfaces</p> <p>Depends on the distance to steel reinforcement</p> <p>A slot needs to be sawn up in the concrete cover</p> <p>The slot needs careful cleaning before bonding</p> <p>Bonded with a thixotropic adhesive</p> <p>Possible to use cement mortar for bonding</p> <p>Protected against impact and vandalism</p> <p>Suitable for strengthening in bending</p> <p>Minor protection against fire</p>

The NSMR laminates are mounted in the slot and the excess adhesive or cement mortar is removed with a spatula or similar. It is interesting to compare traditional laminate and sheet plate bonding with NSMR, and this is done in Figure 1 and Table 1.

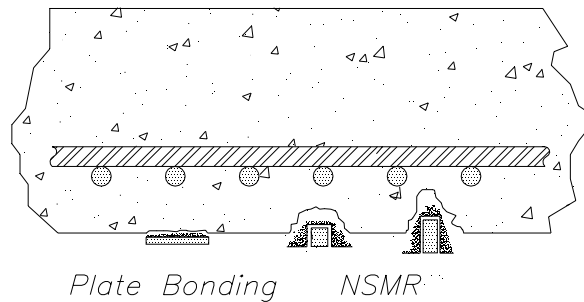

Figure 1. Comparison between laminate Plate Bonding and NSMR

In Figure 1, the difference between laminates and NSMR can be seen. The energy required to remove NSMR is in many cases much larger than that for bonded laminates. Furthermore, NSMR resists end peeling much better than bonded laminates and is considerably more protected against fire, vandalism and impact from e.g. vehicles. However, in some applications it demands a greater effort to carry out the work on site. An overview of the main characteristics and some typical aspects of these three types of strengthening methods with FRP are given in Table 1. Also, see (FIB Bulletin 14, 2001) and (Täljsten, 2002).

#### 4. THEORY

Theory derived for the ultimate bending capacity of concrete beams strengthened with NSMR can be found in Täljsten (2000, 2002), Nordin et al. (2001), Täljsten and Carolin (2001) and so will only be described shortly here. However, in design for strengthening with NSMR the following assumptions are made:

- Bernoulli's hypothesis applies, i.e. linear strain across the cross-section varies rectilinearly. This implies that linear strain in the concrete, steel reinforcement and laminate that occurring at the same level is of the same size. Composite action applies between all the materials involved.
- Concrete stresses are obtained from the material's characteristic curve. Concrete compressive strain is limited to an approved failure strain of  $\epsilon_{cu} = 3.5 \text{ ‰}$ .



- For a cracked cross-section, the concrete's residual tensile strength is ignored.
- The stresses in tensile and compression steel reinforcement are taken from the reinforcement's characteristic curve corresponding to the total strain. The total strain may not be greater than the failure strain.
- The laminate stress is obtained from the characteristic curve of the material. The total strain in laminate may not exceed the failure strain.
- The laminate is assumed to be linearly elastic until breakage, i.e. Hooke's law applies.

In addition it is important to notice that if there exists a strain field on the structure, due to for example the dead load, this must be considered in design. In figure 2(b) this is shown schematically, where  $\epsilon_{u0}$  is the initial strain in the bottom face of the cross section.

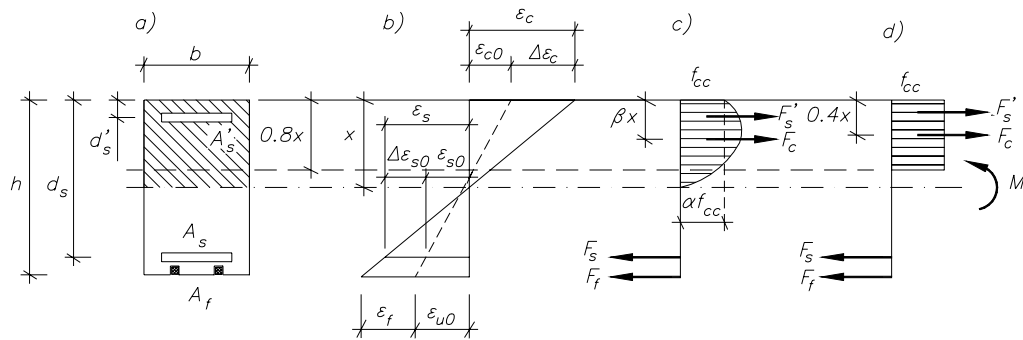

Figure 2. Principles for strengthening in bending

The influence of the creep in the concrete is taken care of with a reduced modulus of elasticity. A calculation is then made to determine whether the concrete is uncracked. The studied section can be considered uncracked if the tensile capacity of the concrete is not exceeded. If the type of failure that can occur is assumed to be failure in the composite material without yielding in the compressive reinforcement, the bending capacity can then be expressed as:

$$M = \frac{x - d'_s}{h - x} (\epsilon_{fu} + \epsilon_{u0}) A'_s E_s (0.4x - d'_s) + A_s f_s (d_s - 0.4x) + \epsilon_{fu} E_f A_f (h - 0.4x) \quad (1)$$

a horizontal equilibrium equation for the section in Figure 2(d) gives:

$$0.8f_{cc}bx + \frac{x-d'_s}{h-x}(\epsilon_{fu} + \epsilon_{u0})A'_sE_s = A_s f_s + \epsilon_{fu}E_f A_f \quad (2)$$

where  $x$  can be solved with an equation of the second degree:

$$C_1x^2 + C_2x + C_3 = 0 \quad (3)$$

where

$$\left. \begin{aligned} C_1 &= 0.8f_{cc}b \\ C_2 &= -0.8f_{cc}bh - (\epsilon_{fu} + \epsilon_{u0})A'_sE_s - A_s f_s - \epsilon_{fu}E_f A_f \\ C_3 &= (\epsilon_{fu} + \epsilon_{u0})A'_sE_s d'_s + (A_s f_s + \epsilon_{fu}E_f A_f)h \end{aligned} \right\} \quad (4)$$

If a pre-stressing force can be applied to the structure, the effect of the dead load can be removed or at least decreased. This is shown in Figure 3. Here the strain field over the cross section has been changed such there is a small tensile force at the top of the beam.

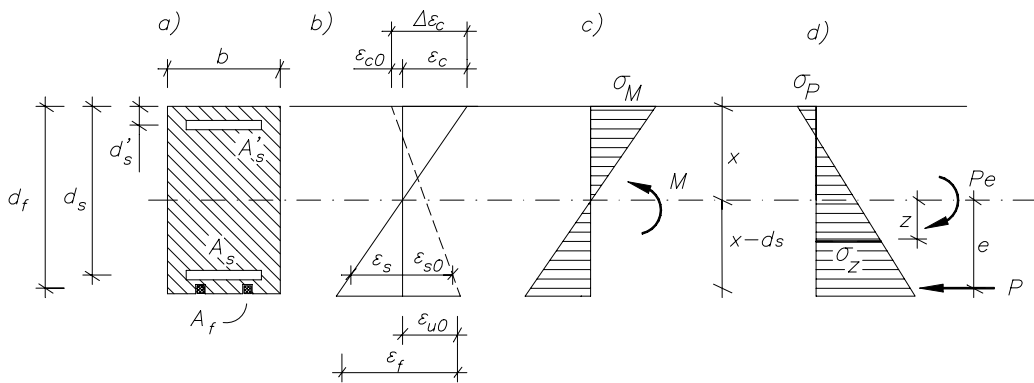

Figure 3. Application of pre-stressing by using NSMR

Anchorage is not covered here, however, it is shown by ongoing research at Luleå University of Technology that the anchorage is better for inserted CFRP compared to surface bonded CFRP reinforcement.

## 5. LABORATORY TESTS

Since 1996 several laboratory tests with NSMR have been carried out at Luleå University of Technology, Division of Structural Engineering. Here, two different test series will be presented, Series I and Series II. First, a test where epoxy bonded and grout bonded rectangular NSMR rods have been tested in four point bending. Second, tests with pre-stressing will briefly be discussed. A more thorough presentation of the tests can be found in Täljsten and Carolin (2001), and Carolin et al. (2001).

In the static four point bending test, Series I, four rectangular concrete beams were manufactured, three were strengthened and one served as a reference beam. The geometry and loading conditions are shown in Figure 4.

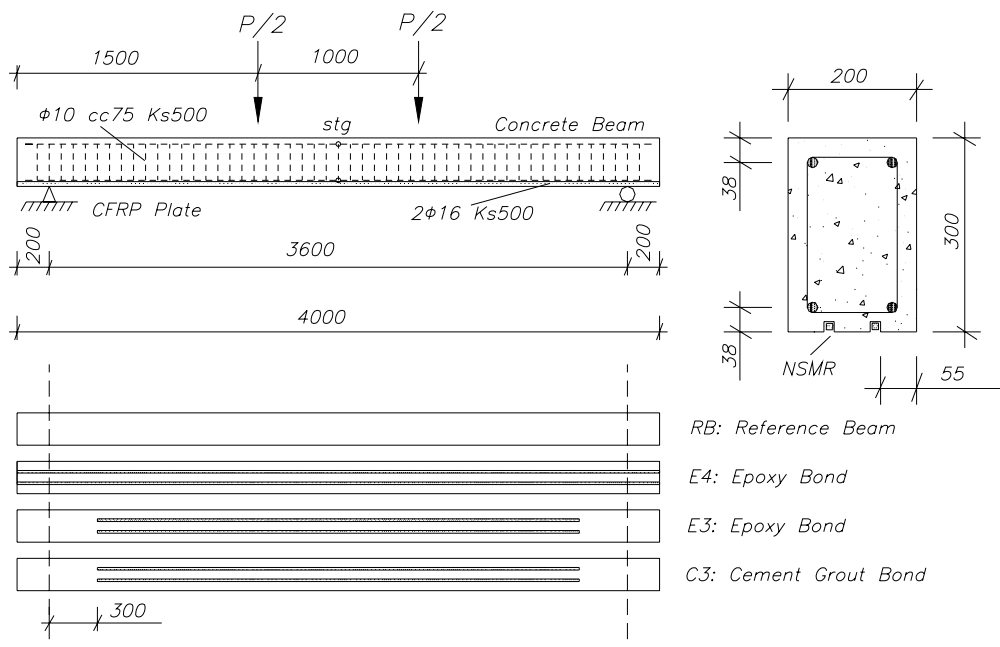

Figure 4. Test set up and dimensions of the beams of Series I

Also the placement of the slots for Series I can be seen in Figure 4. The size of the slots for epoxy bonded rods is 15 x 15 mm and for the cement grout bonded rods 20 x 20 mm. The slots were sawed 55 mm from the side of the beam, and symmetrically placed. All of the beams were loaded in deformation-controlled mode with a head displacement of 0.6 mm/min. Measurements were taken of the load, mid-span, settlement at the support and strains in the laminates. Crack distributions and widths were recorded at every 10 kN. The NSMR laminates were manufactured by vacuum infusion at SICOMP AB and measurements

after tests showed a fibre content of 50 % in the laminates, which then give a Young's modulus of 115 GPa. The corresponding strain at failure is 1.8 %. Both epoxy bond and cement grout bond NSMR 10 mm square rods were used. Before the grout bonded rods were placed in the pre sawn slots the surfaces was pre-treated by bonding quartz sand to them. The material data for the steel reinforcement, concrete and carbon fibre used can be found in Table 2.

Table 2. Material data of Series I test beams

	$f_{cc}$ [MPa]	$f_{ct}$ [MPa]	$f_{st}$ [MPa]	$E_s$ [GPa]	$f_{cu}$ [MPa]	$E_f$ [GPa]	$\epsilon_{fu}$ [‰]
Concrete	60.7	3.6					
Steel			490	200			
Carbon Fibre					4140	230	18.0

The adhesive used, BPE<sup>®</sup> Lim 465, had the following material properties; Young's modulus,  $E_a = 7.0$  GPa, compressive strength,  $f_{ca} = 103$  MPa and tensile strength,  $f_{ta} = 31$  MPa with a viscosity of 28 Pas. The mortar used, Bemix High Tech 305, had the following material properties; compressive strength  $f_{cc} = 60$  MPa after 28 days,  $d_{max} = 0.2$ , with a tixotropic consistency. Recommended application thickness is 0 - 5 mm.

The load deflection curves from the tests are presented in Figure 5. The ultimate loads strains in the CFRP rods at mid-span and deflections are given in Table 3. In Figure 5 is a photo of Beam E3 during preparation also shown. It can clearly be noticed in Figure 5 that Beam E4, as expected, has the best failure envelope, where failure was by rupture of the rod. Beam E3 and Beam C3 follow each other up to the level where an anchorage failure arises in the cement grout for Beam C3. In Beam C3 cracks parallel to the laminates appeared and while the load increased the mortar started to fall down from the beam. Beam E3 showed a more ductile behaviour but also suffered an anchorage failure. The anchor failures are not the same type of peeling-off failure noticed for laminate strengthen beams where a sudden and brittle failure often can be noticed. For Beam C3 and E3, the anchor failure was more to be defined as slippage between the rod and the concrete in the slot.

Theoretical calculations of the load capacity for the tests were also performed, and the results from these calculations are shown in Table 4. In Table 4, the measured strains at failure for the laminates were used for calculating the theoretical failure loads.

Table 3. Results from Series I tests

Beam	Ultimate load [kN]	Ultimate deflection [mm]	Strain at failure [%]
C3	123.5	43.0	0.74
E3	140.0	51.5	1.12
E4	152.0	58.5	1.15
Reference	79.0	24.0	---

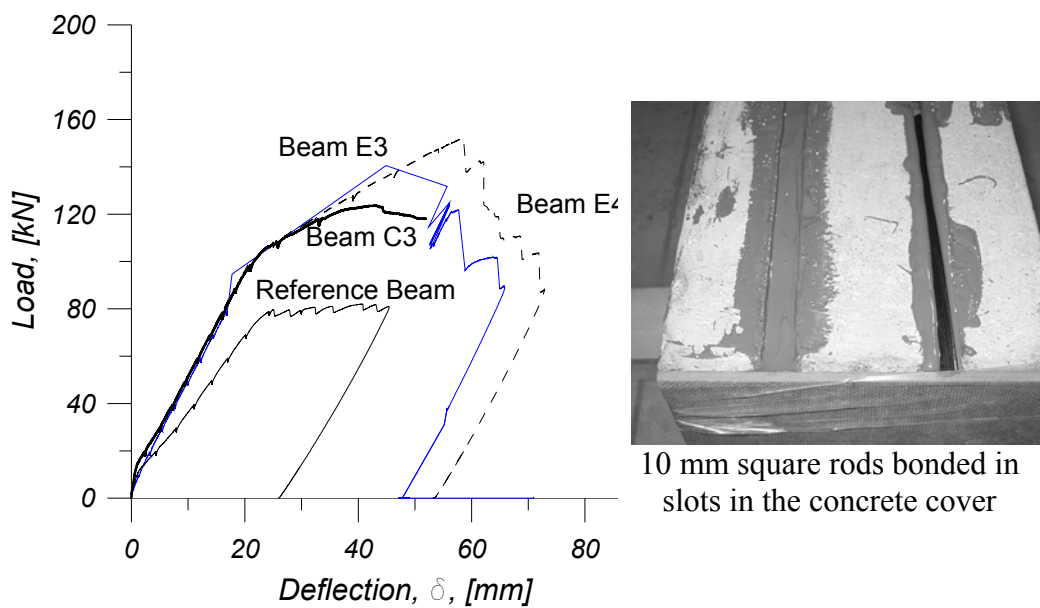

Figure 5. Load- deflection curves for the tested beams of Series I and beam E4 during preparation

Table 4. Theoretical calculations compared with loads at failure for Series I tests

Beam	Ultimate load [kN]	Calculated load [kN]	Ultimate/ Calculated	Type of failure
C3	123.5	149.3	0.83	Anchorage
E3	140.0	167.7	0.83	Anchorage
E4	152.0	176.3	0.86	In rod
Reference	79.0	---	---	Steel yielding

It can be noticed in Table 4 that the theory overestimates the failure load. There can be numerous reasons for this. For Beams C3 and E4 where we had an anchorage failure, the theory described in this paper does not cover this. However, for beam E4, a higher failure load was expected, but it is possible that the strain was higher in the CFRP rod than the one measured by the strain gauges, for example concentrated at a nearby bending crack in the beam. Another more reason could be that the steel yield stress was higher than the one given by the manufacturer.

The next series of tests to be presented, Series II, are on beams strengthened with pre-stressed NSMR rectangular rods. In these tests, several problems were addressed during pre-stressing. Firstly, how to pre-stress the NSMR rods and up to what level? Secondly, how can sufficient anchorage length for the pre-stressed rod be ensured? Moreover, how much loss of pre-stress will occur when the pre-stressing equipment is disconnected? It was decided not to pre-stress higher than 20 % of the ultimate stress in these tests. There are two main reasons for this: in field applications it will most likely be impossible to anchor the NSMR rods for very high stresses; and the shear stresses at the concrete surface will probably be too high for the dimensions of the NSMR rods used. However, this will be investigated in additional tests. The pre-stressing was achieved with the beams on the floor, with the bottom facing up.

The slots were cleaned by removing all contaminations such as dust and small particles and were then filled with a sufficient amount of adhesive. The rods were then positioned in the adhesive filled slots. Each of the rods had 5 strain gauges bonded to the outer surface, one just outside the end of the concrete beam, three within the last 400 mm of one end of the beam and one in the middle. The placement of the strain gauges are shown in Figure 6 together with the test set up and the dimensions of the beams.

The rods were then subjected to a pre-stressing force until a strain of approximately 2000 micro strain was achieved, this corresponds approximately to a stress in the rod of 320 MPa. However, about 5 % of the pre-stress was lost due to problems with the equipment. The epoxy adhesive cured for 5 days before releasing the pre-stressing force, here an additional strain loss of 2 % was recorded in the centre of both beams, BP1 and BP2, see Table 5.

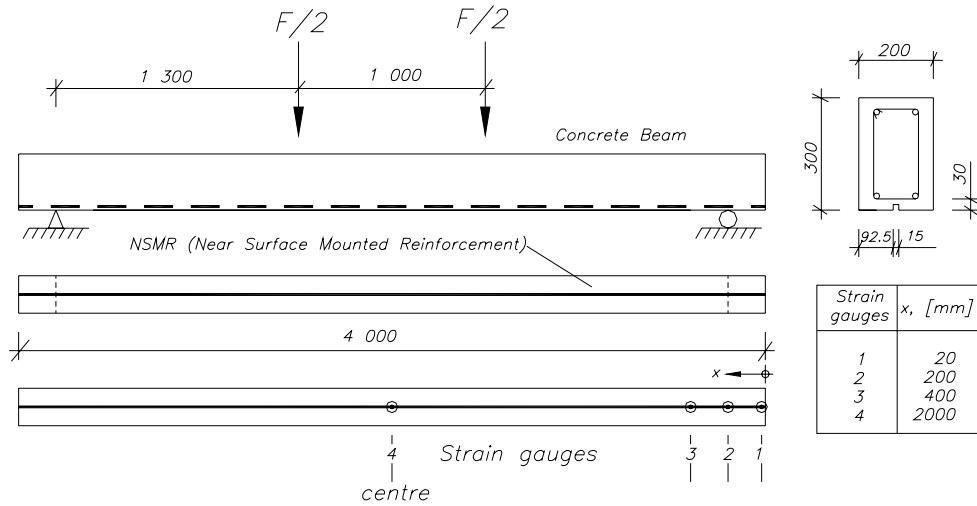

Figure 6. Test set-up of beams of Series II

Table 5 . Strains in the CFRP during pre-stress

Beam	Initial strain [ $\mu$ strain]	Strain after curing [ $\mu$ strain]	Strain after release [ $\mu$ strain]	Strain loss [%]
BP1 (Strain gauge 4)	1813	1802	1708	5.2
BP1 (Strain gauge 1)	1872	1849	533	71.2
BP2 (Strain gauge 4)	1887	1869	1816	2.8
BP2 (Strain gauge 1)	1951	1932	409	78.8

The additional loss is most likely a combination of leakage in the hydraulic cylinder, shear deformation of the adhesive in the connection between the CFRP and concrete and strain loss in the CFRP. When the pre-stress was released the gauge closest to the end of the beam, approximately 20 mm from the end, showed more than 70 % strain loss for both BP1 and BP2. The rest of the gauges showed a loss of strain less than 5 % for both beams, which indicated that most of the pre-stress was transformed to the concrete beam as

expected. There was no mechanical anchorage used in the test, the adhesive had to take all the shear stresses after curing. Figure 7 shows the test beams during pre-stressing and Figure 8 shows a schematic sketch of the anchorage detail used during pre-stressing.

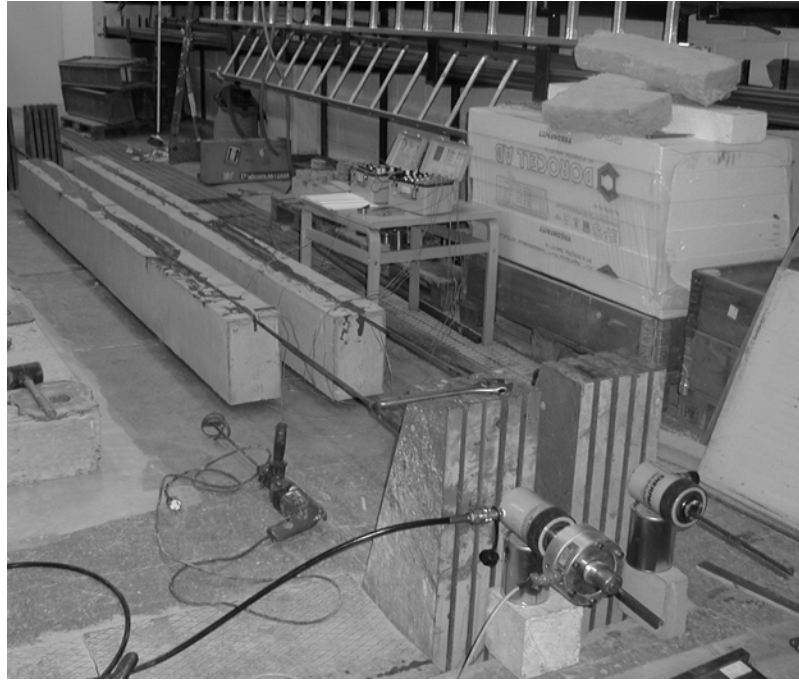

Figure 7. Pre-stressing setup

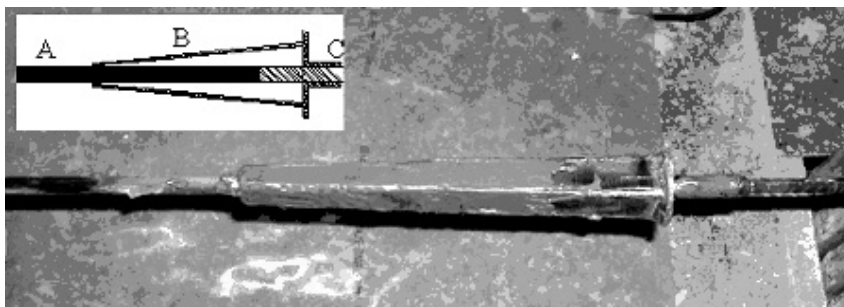

Figure 8. Details of the connection between CFRP and steel during pre-stressing, A) CFRP rod, B) steel cone filled with adhesive, C) steel bar welded to the cone



The purpose of the shape of the anchorage detail, shown in Figure 8, is that a more uniform pressure to the CFRP rod is achieved during pre-stressing. However, it was not possible to verify this through these tests.

The material data of the concrete and CFRP rods are recorded in Table 6. The square 10 mm NSMR rods were delivered by BPE<sup>®</sup> Systems AB in Sweden and was manufactured by pultrusion, where the Young's modulus was 160 MPa and the strain at failure 1.75 %. For the steel reinforcement the characteristic value, quoted by the supplier, of the steel has been used, i.e.  $f_{ys} = 500$  MPa and  $E_s = 205$  GPa. The adhesive used is the same as for test Series I.

Table 6. Material data of Series II test beams

Beam	$f_{cc}$ [MPa]	$f_{ct}$ [MPa]	$E_f$ [GPa]	$\epsilon_{fu}$ [‰]	$\sigma_f$ [MPa]
Reference	61	3.5	---	---	---
BNP	64	3.6	160	17.5	2 800
BP1	68	3.8	160	17.5	2 800
BP2	68	3.8	160	17.5	2 800

The beams were subjected to four-point loading as shown in Figure 6 with a free span of 3600 mm, the beams tested were 4 meters long with a cross section of 200 x 300 mm. Four beams were tested, one reference beam, one beam strengthened without pre-stress and two strengthened with pre-stress. The beams that were strengthened had a slot sawed underneath the beam with a cross section of 15 x 15 mm. The beams were reinforced for shear with  $\phi 10$  steel stirrups at 75 mm spacing and with 30 mm concrete cover. The longitudinal steel reinforcement was  $\phi 16$ , two at the top and two at the bottom, placed directly inside the stirrups.

The load-deflection curves for the four beams are shown in Figure 9. All the strengthened beams had fibre fracture as the failure mode. The strengthening increased the ultimate load by almost 70 % compared with the reference beam. Beams BP1 and BP2 had; a 37 % increase in load before the steel yielded compared with the unstressed beam BNP; and an increase in the cracking load of about 100 % compared with the reference beam; but the same ultimate load as BNP.

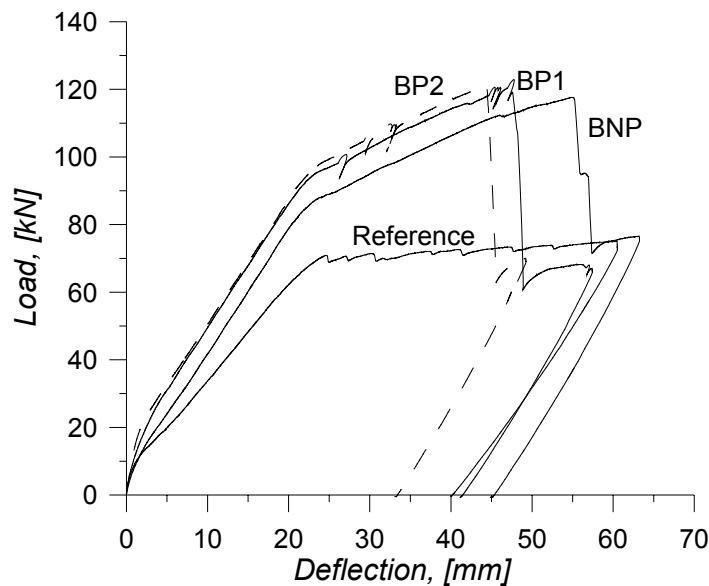

Figure 9. Results from Series II tests

Studying Figure 9 shows that the stiffness of the beam was about the same for the non-pre-stressed and the pre-stressed beams but the pre-stress helped in delaying concrete cracking and yielding of the steel reinforcement. It can also be noticed that the non-pre-stressed beam BNP had a larger deflection than the pre-stressed beams BP1 and BP2. In Table 7 the first crack, steel yielding and ultimate load together with the maximum deflection are shown. All strengthened beams failed by fibre failure in the NSMR rod.

Table 7. Loads and deflections from Series II tests

Beam	First crack [kN]	Steel yielding [kN]	Ultimate load [kN]	Ultimate deflection [mm]
Reference	10	71	75	60
BNP	16	84	118	55
BP1	19	96	121	46
BP2	21	99	121	44

The increase in load for steel yielding can be very important during the life of the member, the fatigue behaviour will improve and the crack widths will be smaller which will result in increased durability.

Further tests will include different amounts of pre-stressing and a comprehensive theoretical investigation on the technique. Furthermore, efforts will also be focused on the development of methods to apply the technique in the field. No mechanical anchorage was used in the tests and a loss of strain in the end zones was measured, in the field, mechanical anchors would most probably be used.

It must be realised that the study is limited and too many conclusions can not be drawn from the results. However, the tests performed show the promising results worthy of future research. The next step will be an extended test series with NSMR rods of different stiffness, different levels of pre-stressing and a special focus on the end anchorage problem. In these tests, more extensive measurements will be taken.

## **6. FIELD APPLICATIONS**

The field application presented here was carried out during the fall of 1999. The reason for strengthening was a mistake at the construction site. The amount of steel reinforcement needed in a joint between a pre-cast concrete element and in-situ cast concrete was not sufficient and strengthening was demanded. The reason for choosing NSMR for this application was the resistance to corrosion of CFRP laminates and comparable stiffness and strength to that of steel. The cross section of the laminates used was 5 x 35 mm, with a Young's modulus of 160 GPa and an ultimate strain at failure of 1.6 %. Furthermore, the main advantage of the NSMR was that the laminates could be placed in the concrete cover and that no great work effort was needed. Laminate plate bonding was also discussed, but since the bridge has a long life and the sealing on the bridge deck is replaced every 20 years, the risk of ripping the laminate off the surface was determined to be very likely. Another concern was the wearing surface, in form of warm asphalt, that was going to be applied.

First the slots (40 x 8 mm) were sawn in the concrete cover. The slots were cleaned carefully and allowed to dry before the adhesive was applied. The strengthening system chosen was BPE<sup>®</sup> NSMR. In Figure 10a, the laminates and the slots in the concrete cover can be seen prior to bonding. In Figure 10b the laminates are bonded in the slot and Figure 10c shows the result after strengthening but before the surface is asphalted.

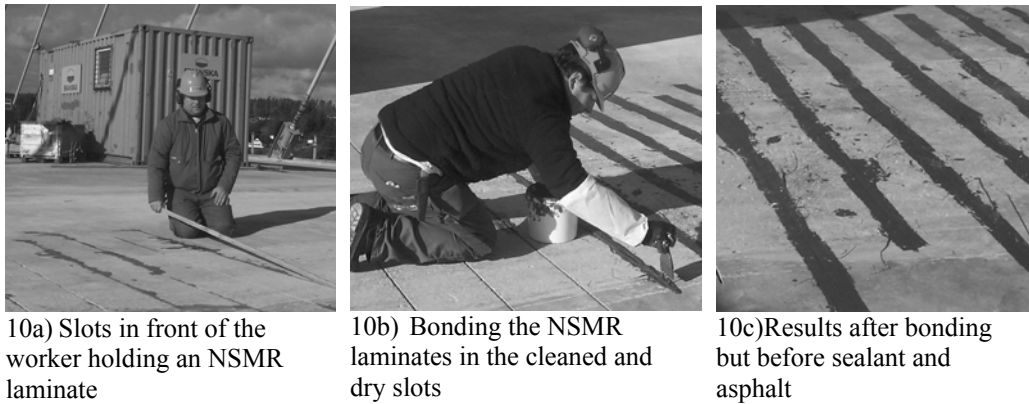

Figure 10. Strengthening of a concrete joint with NSMR.

The client, The Swedish Road Authority, considered the strengthening work successful and it is today an accepted method of strengthening concrete bridges.

## 7. FUTURE WORK

Several research programs are ongoing at Luleå University of Technology, Division of Structural Engineering. A project that has just been finished is “Behavior of Plate Bonded Concrete Beams in Cold Climate”. Here, CFRP strengthened concrete beams, both laminates and NSMR, have been tested at  $-30\text{ }^{\circ}\text{C}$  and compared with beams tested at room temperature. The primary results from these tests are that no decrease in load could be noticed for beams tested in cold climate. Results from these tests will be reported. During 2002, focus will be placed on NSMR applications. Firstly, anchorage will be studied, secondly the possibility to use pre-stressed NSMR will be investigated further and finally a full-scale application to strengthen a road bridge for the Swedish Road Authorities will be carried out.

## 8. CONCLUSIONS

There is no doubt that strengthening concrete structures with NSMR is an effective method.

The tests presented in this paper show promising strengthening results and a considerable strengthening effect could be noticed. Pre-stressing increased the steel yielding load and delayed concrete cracking. The theory presented covers

traditional design for bending, however, more work is needed to also cover anchorage and other types of strengthening applications.

The field application presented shows that it is easy to strengthen structures and the method is not only time saving but also beneficial from a financial point of view.

#### ACKNOWLEDGEMENT

The authors acknowledge the financial support that has been provided by Skanska AB, SBUF (The Development Fund of the Swedish Construction Industry) and BPE<sup>®</sup> Systems AB. Also Georg Danielsson and Håkan Johansson at Testlab, Luleå University of Technology are acknowledged for their help and support with the testing.

#### REFERENCES

- Asplund, S.O. (1949), "*Strengthening Bridge Slabs with Grouted Reinforcement*", Journal of the American Concrete Institute, Vol. 20, No. 6, January, pp. 397-406
- Blaschko, M. A. (2001), "*Zum Tragverhalten von Beetonbauteilen mit in Schlitze eingeklebten CFK-Lamellen*", Doctoral Thesis ISSN 0941-925X, pp 150 (In German).
- De Lorenzis, L., Nanni, A. and La Tegola, A. (2000). "*Flexural and Shear Strengthening of Reinforced Concrete Structures with Near Surface Mounted FRP Rods*" Advanced Composite Materials in Bridges and Structures, Proc. of 3rd Int. Conf., Ed. Humar, J.L. and Razaqpur, A.G. Ottawa, ISBN: 0-7709-0447-5, pp. 521-528.
- Benmokrane B. And Rahman H. Eds., 1998, "*Durability of fibre reinforced polymer (FRP) composites for construction*", Department of Civil Engineering, Université de Sherbrooke, 1998.
- Carolin, A., Nordin, H. and Täljsten, B. (2001): "*Concrete beams strengthened with near surface mounted reinforcement of CFRP*" International Conference on FRP Composites in Civil Engineering, Volume 2, J.-G. Teng (Ed). ISBN: 0-08-043945-4 pp 1059-1066
- FIB, 2001, Bulletin 14, *Externally bonded FRP reinforcement for RC structures*, Technical Report, Task Group 9.3 FRP (Fibre Reinforced Polymer) reinforcement for concrete structures, ISBN 2-+88394-054-1, p 130, July 2001.
- Maruyama K., 1997, "*JCI activities on continuous fibre reinforced concrete, Non-Metallic (FRP) Reinforcement for Concrete Structures*", Japan Concrete Institute, pp 3-12, 1997.

---

Meier U. And Betti R. Eds., 1997, “*Recent advances in bridge engineering – Advanced Rehabilitation, durable materials, non-destructive evaluation and management*”. EMPA Switzerland.

Nanni A., (2001), “*North american design guidelines for concrete reinforcement and strengthening using FRP: Principles, applications and unresolved issues*“, International Conference of FRP Composites in Civil Engineering, Volume 1, J-G. Teng (Ed.), ISBN 0-08-043945-4, pp 61-72.

Neale KW. And Labossière P., (1997), “*State-of-the-art report on retrofitting and strengthening by continuous fibre in Canada*”, Non-Metallic (FRP) Reinforcement for Concrete Structures, Japan Concrete Institute, pp 25-39.

Nordin, H., Täljsten, B. and Carolin, A., (2001), “*Concrete beams strengthened with prestressed near surface mounted reinforcement (NSMR)*” International Conference on FRP Composites in Civil Engineering Volume 2, J.-G. Teng (Ed). ISBN: 0-08-043945-4, (2001), pp 1067-1075.

Rizkalla S. and Hassan T. (2001), “*Various FRP strengthening techniques for retrofitting concrete structures*”, International Conference on FRP Composites in Civil Engineering, Volume 2, J-G Teng (Ed.), ISBN 0-08-043945, pp 1033-1040.

Thomas J., (1998), “*FRP strengthening – Experimental or mainstream technology?*”, Concrete International, ACI, pp57-58.

Triantafillou T. C., (1998), “*Shear Strengthening of Reinforced Concrete Beams Using Epoxy-Bonded FRP Composites,*” ACI Structural Journal, Vol. 95, No. 2, March-April, pp 107-115.

Täljsten B., (1997), “*Strengthening of Beams by Plate Bonding*”, Journal of Materials in Civil Engineering, November, pp. 206-212.

Täljsten, B. (2000): “*Förstärkning av befintliga betongkonstruktioner med kolfiberväv eller kolfiberlaminat – Dimensionering, material och utförande*” In Swedish. Technical report. Luleå University of Technology, Division of structural engineering, 119 pp

Täljsten, B. and Carolin, A. (2001): “*CFRP - Strengthening. Concrete Beams Strengthened with Near Surface Mounted CFRP Laminates*” Fibre reinforced plastics for reinforced concrete structures, FRPRCS-5, Cambridge (Edited by Chris Burgoyne), pp 107-116.

Täljsten, B. (2002): “*FRP Strengthening of Existing Concrete Structures - Design Guidelines*”. Luleå University of Technology, Division of structural engineering, ISBN 91-89580-03-6, p230.

**NOTATIONS**

$A_f$	cross-sectional area of FRP	[m <sup>2</sup> ]
$A_s$	area of tensile steel reinforcement	[m <sup>2</sup> ]
$A'_s$	area of compression steel reinforcement	[m <sup>2</sup> ]
$C_1$	constant	[N/m]
$C_2$	constant	[N]
$C_3$	constant	[Nm]
$E_a$	modulus of elasticity of adhesive	[Pa]
$E_f$	modulus of elasticity of FRP	[Pa]
$E_s$	modulus of elasticity of steel	[Pa]
FC	normal force, concrete	[N]
Ff	normal force, FRP	[N]
FS	normal force, tensile steel	[N]
$F'_s$	normal force, compressive steel	[N]
$M$	bending moment	[Nm]
$b$	width	[m]
$d_f$	effective height to FRP	[m]
$d_{max}$	maximum aggregate size for grout	[mm]
$d_s$	effective height to tensile reinforcement	[m]
$d'_s$	effective height to compression reinforcement	[m]
$f_{cc}$	compressive strength, concrete, grout	[Pa]
$f_{ca}$	compressive strength, adhesive	[Pa]
$f_{ct}$	splitting strength, adhesive	[Pa]
$f_{cu}$	failure stress, FRP	[Pa]
$f_s$	yield stress in tensile reinforcement	[Pa]
$f'_s$	yield stress in compression reinforcement	[Pa]
$f_{ta}$	tensile strength, adhesive	[Pa]
$h$	height	[m]
$x$	inner lever arm	[m]
$\epsilon_c$	strain in concrete	[--]
$\epsilon_{c0}$	compressive strain, unconfined concrete	[--]
$\Delta\epsilon_c$	additional strain in concrete	[--]
$\epsilon_{c0}$	compressive strain in concrete, upper side, remaining strain	[--]
$\epsilon_{cu}$	compressive strain in concrete, upper side, ultimate strain	[--]

---

$\varepsilon_f$	strain of FRP	[--]
$\varepsilon_{fu}$	failure strain of FRP	[--]
$\varepsilon_s$	strain of tensile steel reinforcement	[--]
$\varepsilon_{s0}$	strain of tensile steel reinforcement, remaining load	[--]
$\Delta\varepsilon_{s0}$	additional strain in tensile steel reinforcement	[--]
$\varepsilon_{u0}$	strain in underside concrete, remaining load	[--]
$\sigma_f$	Tensile strength of FRP	[Pa]
$\sigma_M$	normal stress due to bending moment	[Pa]
$\sigma_P$	normal stress in concrete	[Pa]



## **APPENDIX D – PAPER IV**

### “Concrete Beams Exposed to Live Loading during CFRP Strengthening”

by Anders Carolin<sup>1</sup>, Björn Täljsten<sup>1,2</sup> and Arvid Hejll<sup>1</sup>

<sup>1</sup>) Luleå University of Technology  
Division of Structural Engineering  
SE-971 87 Luleå  
Sweden

<sup>2</sup>) Skanska Teknik AB  
SE-169 83 Solna  
Sweden

Submitted for publication in  
*Journal of composites for construction.*



## CONCRETE BEAMS EXPOSED TO LIVE LOADING DURING CFRP STRENGTHENING

*By Anders Carolin<sup>1</sup>*

*Björn Täljsten<sup>2</sup>*

*Arvid Hejll<sup>3</sup>*

### Abstract

The need for structural rehabilitation of concrete structures all over the world is well known. Extensive amounts of research have been carried out and are going on in this field. Most of the laboratory research has been undertaken on structural elements without live load during the strengthening process. Normally, owners of structures want to continue with their activity or service during strengthening. Full-scale applications have shown that this is possible, but there is a lack of understanding as to how cyclic loads during strengthening, for example traffic loads affect the final strengthening result. This paper presents laboratory tests on concrete beams strengthened with CFRP (Carbon Fiber Reinforced Polymers) laminates and NSMR (Near Surface Mounted Reinforcement). The beams were subjected to a cyclic load during setting of the adhesive. After additional hardening, the beams were then loaded by deformation control up to failure. For bonding, normal cold cured epoxy adhesive has been used as well as cementitious mixtures. The results show that strengthening with CFRP systems are possible even if loads act on the structure during the strengthening phase.

---

<sup>1)</sup> Tech Lic. MSc., Luleå University of Technology, Division of Structural Engineering, 971 87 Luleå, SWEDEN

<sup>2)</sup> Dr. Prof., Luleå Univ. of Technology, 971 87 Luleå, SWEDEN and Skanska Teknik AB, 169 83 Solna, SWEDEN

<sup>3)</sup> MSc., Luleå University of Technology, Division of Structural Engineering, 971 87 Luleå, SWEDEN

Key Words: Concrete, Bending, Bearing capacity, Beams, Retrofitting, Carbon, Live loads,

---

## Introduction

In the last decades it has become more and more important to repair and strengthen existing structures. The reasons for this are numerous, and vary for each and every case. Many different methods can be suitable as choice, for example shotcrete with steel fibers, additional steel reinforcement covered by concrete, and post-tensioning, just to mention a few. One repair and strengthening method that has been growing rapidly for at least the last 10 years is plate bonding with Fiber Reinforced Polymers, (FRPs), (Täljsten 1994; Karbhari and Seible 1999). FRP, also referred to as composites, is a material with high stiffness and strength and it serves as an outer reinforcement when bonded on to a structure's surface. The material is lightweight, does not corrode and can come in almost any shape, length, and dimension. The reinforcement can be in form of laminates that are bonded to plain surfaces, or the composite can also be built up by hand lay-up with a thin fabric on the structure and is therefore possible to use on curved surfaces as well. The method has been found to be applicable for both strengthening in shear and flexure. It has been found that the method also works in cold climates, (Carolin and Täljsten 2002). The advantages and drawbacks of the method can vary between the objects and must always be considered, (Carolin 2001). It has been found that the outer reinforcement can be damaged from vehicle impacts and it can be necessary to protect the composite when used in applications if risks of impact exist. The consequences from loss of strengthening effectiveness by fire, vandalism, collision etc must also be considered, (Chaallal et al. 1998). A variant of plate bonding is Near Surface Mounted Reinforcement, NSMR. In NSMR the rods are placed in pre-sawn grooves in the concrete cover instead of on to the surface. When NSMR is possible, it provides better anchorage in the concrete, some protection for the strengthening system, and in some cases also easier installation. The shear force is transferred into the rod on three sides, which makes peeling forces at the end less critical compared to traditional plate bonding. Some researchers, (Blaschko 2001), use rectangular laminates in narrow deep slots, and others, (Rizkalla and Hassan 2001) have used circular rods. At Luleå University of Technology the NSMR method was developed during 1996 using quadratic cross-section rods. The cross-section was chosen for several reasons. When the grooves are sawn they will have vertical and parallel sides, therefore it is beneficial with rectangular cross-sections. This gives a larger bonding to reinforcement area ratio and a more uniform adhesive thickness compared to circular rods. When it comes to the dimensions of the rod, a more flat laminate needs a deeper groove to give the same reinforcement area. On laboratory beams, this will not cause any problem since the concrete cover can be design to fit desired requirements. On existing structures, especially old ones, the concrete cover will vary. It can be found to vary 300 % from the design value, (Enochsson et al. 2002). On old concrete structures it is even possible to spot corroded rebars on the surface. It has been found that a quadratic cross-section of  $10 \times 10 \text{ mm}^2$  provides good anchorage as well as easy installation.

There has been discussion, mainly based on lack of knowledge, as to how to handle epoxy products. For this reason there has been an interest in investigating alternatives to epoxy as a bonding agent. Previous tests have shown that it is possible to strengthen with the NSMR technique and to use a concrete mortar as bonding agent instead of epoxy, (Carolin et al. 2001). In the case of a cementitious bonding agent the rods must have an outer layer of quartz sand to ensure bonding between the rod and the mortar. Further description of the usage of NSMR can be found in Täljsten and Carolin 2001; Nanni 2001; Rizkalla and Hassan 2001. A brief understanding of NSMR can be found by studying FIG. 1, where the insertion of the rods in the concrete cover is shown.

Most laboratory studies, with both NSMR and traditional plate bonding, have been carried out on beams placed upside down on a flat surface when the strengthening has been applied. This means that the beams are completely unloaded, including self-weight, when the CFRP is bonded to the structure. Some studies have been undertaken with a strain field on the strengthened cross-section, i.e. dead load, (Weijian and Huiming 2001). Initial strains on a cross-section can be handled in most design proposals, (Täljsten 2002). Studies with an over time changing strain field have not been reported. This corresponds to live loading during the strengthening process, i.e. for example traffic on a bridge during curing of the adhesive.

For owners and end users, it is an important question to know whether it is possible to keep the structure in service during the strengthening process. Large costs are often connected to limiting the service of a bridge, not to mention the irritation and delay for end users. Alternative routes, traffic signs and signals need to be used. Scheduled traffic is delayed or needs to be cancelled. Plate bonding has been used in several applications where the strengthening has been applied during nighttime with minimal disturbance for society and with the structure back in service the following day. The best case of applying a strengthening is if the structure can be completely unloaded, including of the self weight, during strengthening. This enhances the utilization of the FRP's contribution before the structure reaches critical stages, yielding of reinforcement, concrete crushing and so on. As presented by Meier et al. (1993) and Nordin et al. (2001), prestressing of CFRP can be one way to achieve a more effective use of the material. However, prestressing of CFRP is not fully developed and will in many cases probably not outdo traditional strengthening when all aspects are considered, for example the extra work due to anchorage. The answer to the owners' question also depends on what kind of structure it is that needs to be strengthened. For structures with high dead loads from for example arches, it is probable that the structure must not only be taken out of service, but the fixtures must also be removed to unload the structure. Bridges are different; they often have a high amount of self-weight compared to the frequent live loads. The vehicles that give the highest loads, trucks or trains in case of a railroad bridge, are less frequent compared to lighter vehicles. Nevertheless, it is of utmost importance to provide answers to whether or not, a structure can be used during strengthening.

This paper presents laboratory tests investigating the effect of live loads during the strengthening process. Both laminate plate bonding and the use of NSMR have been investigated. For the NSMR applications both epoxy and a cementitious bonding agent have been studied.

## Experimental Program

The tests have been undertaken on rectangular reinforced concrete beams presented in FIG. 1 and FIG. 2.

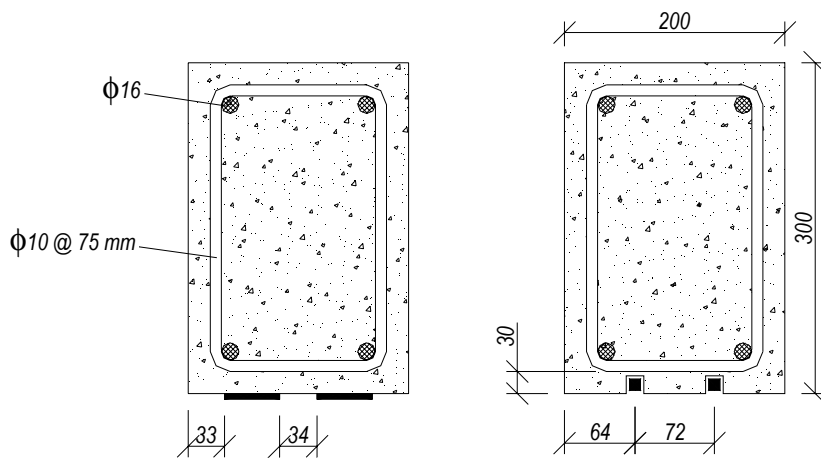

FIG. 1. Cross-sections of test specimens

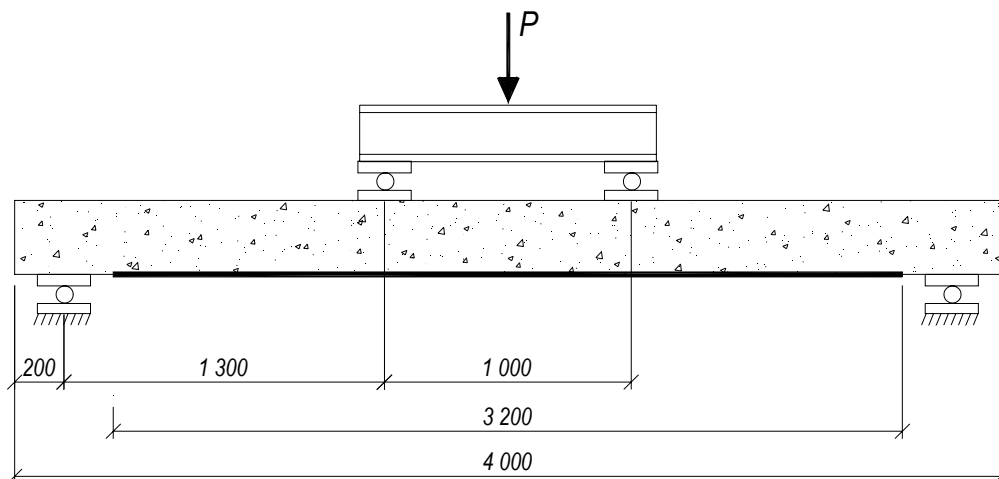

FIG. 2. Test specimens

Previous full-scale tests compared with existing theories have shown that the size of the beams gives reliable results for the strengthening system, (Täljsten and Carolin 1999). The size effect might be different for the case with live loads during strengthening but is not covered within this study. The beams were heavily reinforced in shear, 10 mm stirrups @ 75 mm spacing, to also ensure a flexure failure when strengthened. A total of 12 beams were tested, 7 beams were strengthened with NSMR and 4 beams with traditional laminate plate bonding. Half of the strengthened beams were strengthened without loads during curing, the other half were subjected to live loads as described later in this paper. The beams were subjected to four-point bending, both during the strengthening phase and when they were loaded up to failure. The beams tested are presented in Table 1.

**Table 1.** Test Specimens

<i>Specimen</i>	<i>Condition</i>	<i>Slot Size [mmxmm]</i>	<i>Strengthening Reinforcement</i>	<i>Adhesive</i>	
<i>Reference beam</i>	-	-		-	
<i>Plate bonding</i>			Area 1.4x50 mm <sup>2</sup>		
<i>LMstat</i>	static	-	BPE <sup>®</sup> Laminate 145 M	epoxy	BPE <sup>®</sup> Lim 567
<i>LMdyn</i>	dynamic	-	BPE <sup>®</sup> Laminate 145 M	epoxy	BPE <sup>®</sup> Lim 567
<i>LSstat</i>	static	-	BPE <sup>®</sup> Laminate 145 S	epoxy	BPE <sup>®</sup> Lim 567
<i>LSdyn</i>	dynamic	-	BPE <sup>®</sup> Laminate 145 S	epoxy	BPE <sup>®</sup> Lim 567
<i>NSMR</i>			Area 10x10 mm <sup>2</sup>		
<i>BMstat</i>	static	16x16	BPE <sup>®</sup> NSMR 101 M	epoxy	BPE <sup>®</sup> Lim 465
<i>BMdyn</i>	dynamic	16x16	BPE <sup>®</sup> NSMR 101 M	epoxy	BPE <sup>®</sup> Lim 465
<i>BSstat</i>	static	16x16	BPE <sup>®</sup> NSMR 101 S	epoxy	BPE <sup>®</sup> Lim 465
<i>BSdyn</i>	dynamic	16x16	BPE <sup>®</sup> NSMR 101 S	epoxy	BPE <sup>®</sup> Lim 465
<i>BShdyn</i>	dynamic	16x16	BPE <sup>®</sup> NSMR 101 S	epoxy	BPE <sup>®</sup> Lim 567
<i>BSstat-cem</i>	static	20x20	BPE <sup>®</sup> NSMR 101 QS	cement	StoCrete GM1
<i>BSdyn-cem</i>	dynamic	20x20	BPE <sup>®</sup> NSMR 101 QS	cement	StoCrete GM1

To investigate the use of cementitious mortar as bonding agent two beams were strengthened with NSMR and cementitious mortar as bonding agent, one under static conditions and one in combination with cyclic loads. The quadratic rods bonded to the beams with cement mortar were covered with a thin layer of quartz sand to improve the anchorage between the rod and the cement mortar used. Before strengthening, the slots were saturated with water to get the best performance of the cement mortar. After the rods had been placed in the slots, the mortar was kept moist for 21 days. All slots in the concrete were cut with a saw after manufacturing of the beams. When epoxy was used, the slot dimension was 16 x 16 mm<sup>2</sup>. The sand-covered rods have a larger cross-section, compared to the original ones, to get the same fiber area. The slots therefore needed to be larger in this case and were made 20 x 20 mm<sup>2</sup>. Two different epoxies were also used in the tests, one low viscosity epoxy and one with a higher viscosity. Properties of the materials used can be found in Table 2.

**Table 2.** Material Properties

<i>Material</i>	<i>Compressive Strength</i> [MPa]	<i>Tensile<sup>4)</sup> Strength</i> [MPa]	<i>Young's Module</i> [GPa]
<i>Concrete<sup>1)</sup></i>	62	3.6	42
<i>Reference beam</i>	61	3.5	
<i>Plate bonding</i>			
<i>LMstat</i>	57	3.7	
<i>LMdyn</i>	64	3.6	
<i>LSstat</i>	57	3.7	
<i>LSdyn</i>	64	3.6	
<i>NSMR</i>			
<i>BMstat</i>	68	3.8	
<i>BMdyn</i>	67	3.9	
<i>BSstat</i>	56	3.0	
<i>BSdyn</i>	56	3.0	
<i>BShdyn</i>	68	3.8	
<i>BSstat-cem</i>	58	3.5	
<i>BSdyn-cem</i>	66	3.7	
<i>Steel reinforcement</i>	515 <sup>2)</sup>	515 <sup>2)</sup>	210
<i>Adhesive<sup>3)</sup></i>			
BPE <sup>®</sup> Lim 567	93	46	7
BPE <sup>®</sup> Lim 465	103	31	7
StoCrete GM1	45	9	26.5
<i>Composite<sup>3)</sup></i>			
BPE <sup>®</sup> Composite M		2000	250
BPE <sup>®</sup> Composite S		2800	160

1) Average

2) Yielding

3) Suppliers data

4) 0,8 x Splitting strength

The properties of the composites and the adhesive are given by the supplier and are not tested. The concrete quality is tested on 150 mm cubes. Empirical relation to the tested split strength obtains the tensile strength of the concrete. The concrete had an age of approximately 180 days and during the test period was considered to be fully cured, without any significant changes of the properties such as compressive strength. The beams were equipped with strain gauges on the concrete, the internal steel bars and on the fibers. In addition to the strain gauges, SG, the midpoint deflection and support settlement were registered with Linear Voltage Differential Transducers (LVDTs), as shown in FIG. 3.



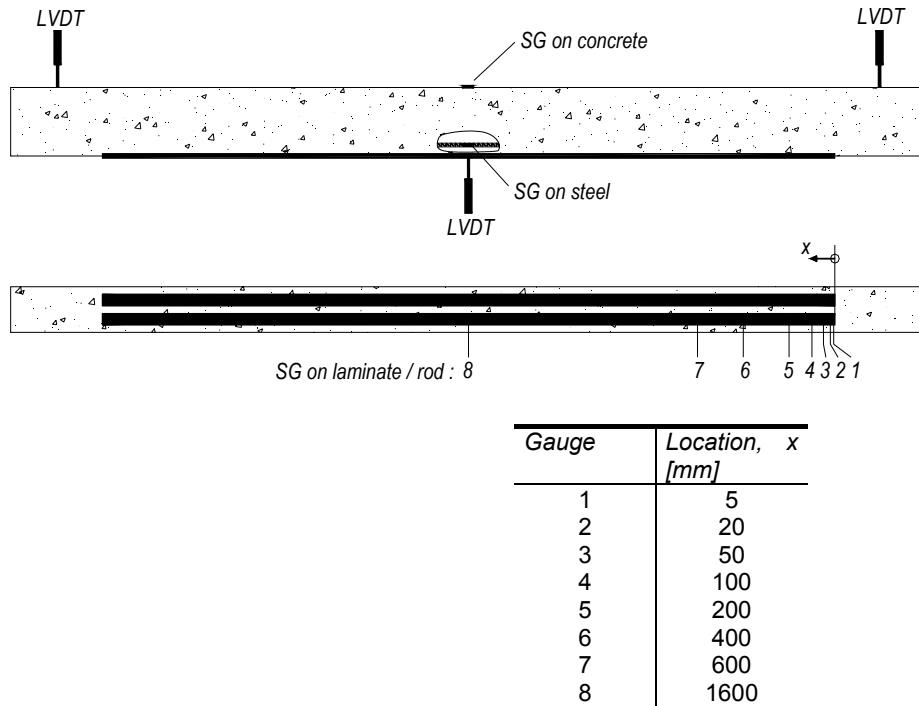

FIG. 3. Monitoring of the specimens

For some tests additional LVDTs were used at the ends of the rods to measure the rod slip during curing of the adhesive. Viscosity tests have also been made on the active parts of the epoxy adhesives. The adhesive also contains fillers, which give the adhesive higher viscosity than indicated in these tests. The viscosity during the first 24 h at time  $t$  of the adhesive can be expressed as

$$\eta_t = e^{kt} \eta_i \quad (1)$$

where  $k$  is the reaction constant and  $\eta_i$  is the initial viscosity at time  $t=0$  presented as in Table 3. The properties have been obtained by rotating viscosity meter isothermal tests which is relevant for the thin bond layers in the tests.

Table 3. Viscosity Parameters

Epoxy	$k$ $10^{-3} [s^{-1}]$	$\eta_i$ [mPas]	Pot Life [min]
BPE <sup>®</sup> Lim 465	0.2337	2597	90
BPE <sup>®</sup> Lim 567	0.3808	4995	60

### ***Strengthening***

Five beams were strengthened while unloaded. The beams strengthened with laminate plate bonding were ground on the surface to expose the aggregates. The surface was then subjected to compressed air to obtain a clean surface with neither dust nor debris. Then the laminates were bonded to the surface and the adhesive was allowed to cure unloaded in 20 °C for seven days at 60 % humidity. The beams strengthened with NSMR had grooves cut by a concrete saw that has two parallel saw-blades. The concrete that remained between was chipped away with a chisel. This gave a groove with two parallel fairly smooth sides and one rough side at the bottom, (FIG. 4A). The grooves were then cleaned and half filled with adhesive before the rods were placed, (FIG. 4B), so that the groove were completely filled and the rod had adhesive on three sides, (FIG. 4C).

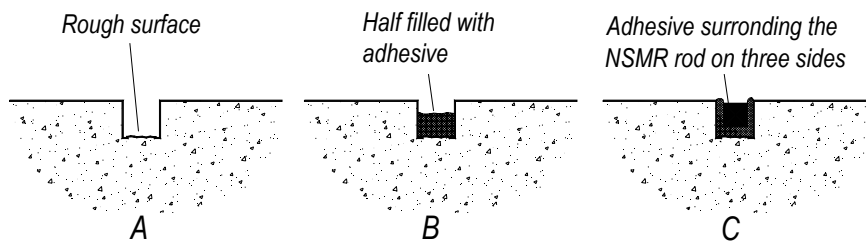

**FIG. 4:** Procedure for strengthening with NSMR

The other five beams were strengthened in the same way, but with live loads acting during curing of the adhesive. Due to the size of the beams they were mounted in the load set-up prior to strengthening. The beams were strengthened upside down to facilitate the monitoring and visual inspection, (see FIG. 5).

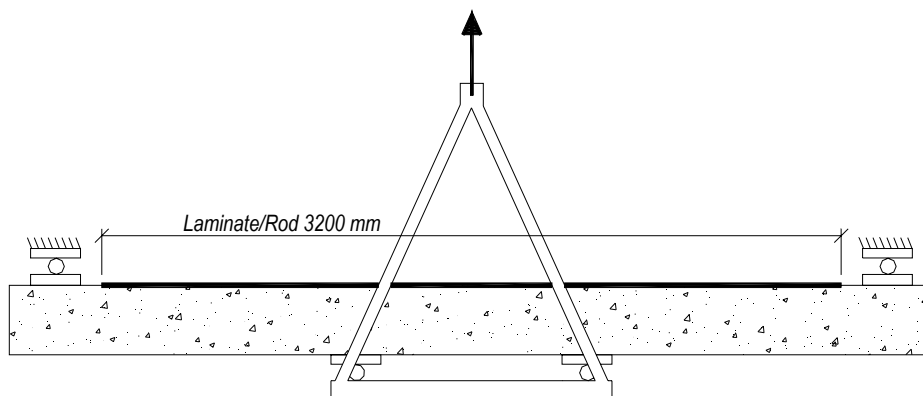

**FIG. 5.** Test set-up for curing under cyclic load

The length of the laminates and rods, 3200 mm, was chosen to be critical for end peeling and anchorage, (Täljsten 1997). This gave laminates and rods that ended between the supports and would therefore not be significantly affected by the bearings. In order to keep the test set-up steady a load of 5 kN was chosen as a lower limit. The load program for the live loads started 20 minutes after the mixing of the two adhesive compounds had commenced. This time allowed the strengthening system to be mounted in the same way for all the beams. Every 108 seconds one “sinus shaped” load cycle in load control mode with a maximum of 40 kN was applied and then the beam was unloaded to 5 kN, (see FIG. 6).

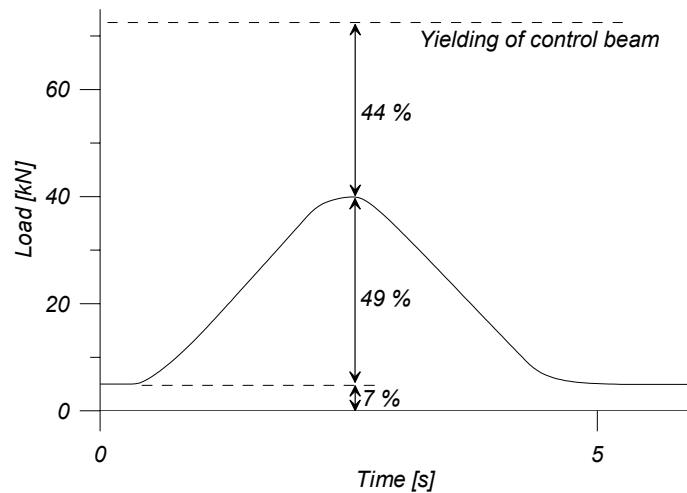

**FIG. 6.** Load cycle applied every 108 s

The load level was chosen to be around 60 % of the load for yielding of internal steel bars for the control beam. The crack load for the control beam was about 10 kN, which means that the strengthened beams were cracked during curing. The frequency was chosen together with Swedish Road Authorities to simulate real conditions for heavier vehicle overpasses on a fairly frequented bridge. The value comes from a real bridge that has 800 overpasses of heavier vehicles each day. This is a frequency of 0.0093 Hz or one overpass every 108 second. It is only of interest to simulate heavier vehicle overpasses since the load and deformation from ordinary private cars can in comparison be negligible. The “sinus shape” of the load-time curve is to simulate the global behavior of a bridge rather than isolating each axel on the vehicle. The beams were subjected to the live load for 72 hours and then unloaded and stored, in controlled environment of 20 °C and 60 % humidity, until they were tested up to failure. The beams strengthened with epoxy adhesive showed no signs of damage after live loading. However, beams strengthened with rods, bonded by cementitious mortar, obtained cracks in the mortar along the whole length of the rods. All strengthened beams except the beam with cementitious mortar were allowed to cure one week after the strengthening commenced until tested to failure. The cementitious mortar was allowed to cure for 28 days under moist conditions.

## Results and evaluation

### Strengthening

The effect of the strengthening system during curing of the adhesive is shown in FIG. 7. The plotted values are measured at the maximum load for every load cycle. The figure shows on the left vertical axis the strains over the cross-section for beam *BShdyn*. The mid-point deflection is also plotted in the same figure with numbers on the right vertical axis. The hardening process can be divided into three distinctive stages, (see FIG. 7).

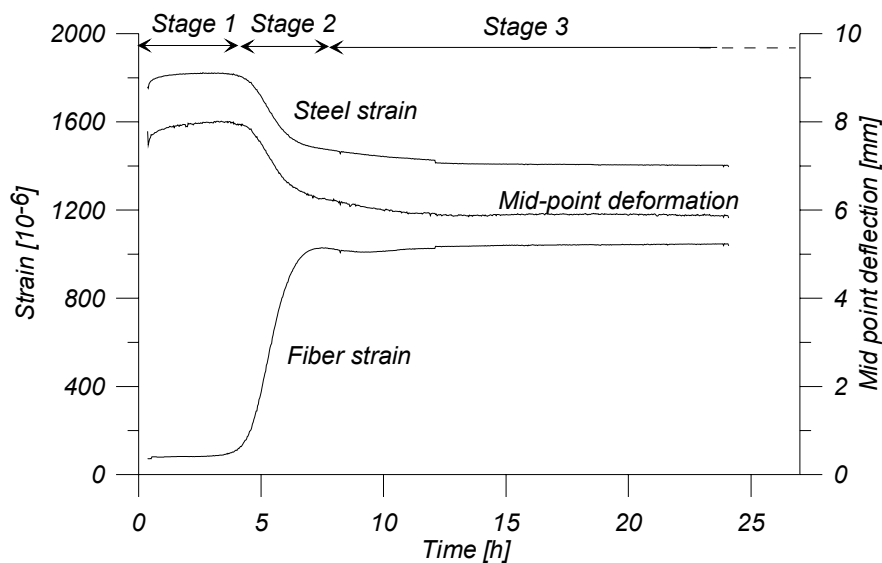

**FIG. 7.** Typical cross-section strains and mid point deformations at peak load for every load cycle.

The first stage is denoted extended potlife, where the polymer does not transfer any significant forces to the composite reinforcement. However, the potlife in traditional meaning is only 90 min for this specific epoxy. The second stage, a hardening phase, begins when the polymer starts to set and forces are transferred into the composite. At the end of stage two the stiffness behavior of the adhesive is reached. In stage three, no changes can be observed in stiffness behavior but polymerization continues until the epoxy is completely set. During stage three the adhesive gains strength and viscosity as presented later in this paper. It can be observed from FIG. 7 that initially the strains slightly increase due to crack formation in the concrete. Then the strains are quite stable until initiation of polymer setting, which seems to occur approximately at 4 hours. As the epoxy cures the composite rods start to be stressed, meanwhile the steel bars are unloaded to an equivalent degree. After setting of the polymer, another 4 hours, the peak strains are unaffected during the remaining load cycles. The mid-point

deflection shows the same behavior and a decrease from 8 mm to 6 mm could be noticed. The deformation from the beginning of the tests gives a deformation to span ratio of  $1/450$ . The decrease of mid-point deflection and steel strains for all beams during hardening of the adhesive can be found in Table 4.

**Table 4.** Level of Mid-point Deflections and Steel Strains for All Beams During Hardening of Adhesive

Specimen	Mid-point Deflection			Steel Strain		
	Before hardening [mm]	After hardening [mm]	Decrease [%]	Before hardening [ $10^{-6}$ ]	After hardening [ $10^{-6}$ ]	Decrease [%]
<i>Plate bonding</i>						
<i>LMdyn</i>	7.6	5.3	30	1870	1440	23
<i>LSdyn</i>	8.4	6.4	24	1220	850	30
<i>NSMR</i>						
<i>BMdyn</i>	8.4	5.2	38	1820	1270	30
<i>BSdyn</i>	8.6	6.4	26	1925	1430	26
<i>BShdyn</i>	8.0	5.9	26	1820	1400	23
<i>BSdyn-cem</i>	8.7	8.7	0	1880	1880	0

From Table 4 it is obvious that the beams, except for *BSdyn-cem*, had gained stiffness from the applied FRP. The mid-point deflections had decreased which is the best indicator of the strengthening effect. There is a larger strengthening effect from the NSMR compared to the laminates. The reason why NSMR shows a higher reduction of the deflection is that more fibers are bonded to these beams. Beams strengthened with high modulus, *M*, CFRP also give a higher strengthening effect than beams strengthened with high strain, *S*, CFRP both regarding laminates and NSMR. During hardening of the cement mortar bonding agent for beam *BSdyn-cem*, cracks occurred along the bond surface. The rod was almost completely loose and only some mechanical anchorages between the quartz sand and the mortar held the rod in place in the middle of the beam. Measured values of the strains in the steel also show that the strengthening has effect on beams bonded with epoxy. However, strains are affected by the distances to the closest crack on each side of the gauge, which are different for all beams, and are therefore, not as good indicators of the strengthening effect compared to the global midpoint deformations. Nevertheless, it is important that the steel has been unloaded by the composite. However, the strains from the lower cyclic load limit, 5 kN, will never be unloaded unless the composite is subjected to prestressing prior to bonding. In stage 1 the biggest relative movements between the composite and the concrete are at the ends of the beams. The movements, caused by elongation on the tension side of the beam while loaded, are presented in FIG. 8.

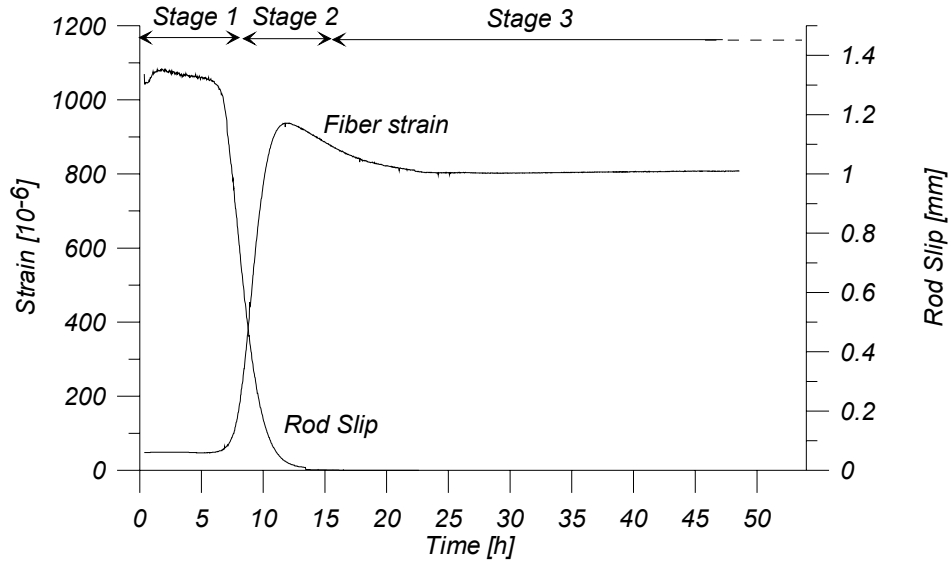

**FIG. 8.** Composite slip in the NSMR slot for BShdyn.

In the middle of the beam, there are no movements because of symmetry. The strain, measured by gauges, (shown in FIG. 3) can be used to evaluate the average shear stress,  $\tau_{i,i+1}$  between the points,  $x_i$  and  $x_{i+1}$  (presented in FIG. 3), along the bond length by equation 2, (Hejll et al. 2003).

$$\tau = \frac{d\varepsilon}{dx} \frac{Et}{3} \Rightarrow \tau_{i,i+1} = \frac{\varepsilon_{i+1} - \varepsilon_i}{x_{i+1} - x_i} \frac{Et}{3} \quad (2)$$

where the strains, at the points  $x_i$  and  $x_{i+1}$ , are  $\varepsilon_i$  and  $\varepsilon_{i+1}$ ,  $E$  is the Young's modulus of the rod and  $t$  is the width of the rod, 10 mm. In Table 5 the measured strains are shown.

**Table 5.** Calculation of shear stresses

Location [mm]	Strain [10 <sup>-6</sup> ]			
	525 min	565 min	740 min	1382min
5	0	0	4	8
20	0	0	4	9
50	1	5	22	27
100	9	21	55	43
200	32	63	121	92
400	80	147	305	333
600	179	284	508	441
1600	383	598	933	804

Shear stresses are presented in FIG. 9 as a function of distance from cut-off end and time from application of adhesive and start of the test; four different times have been plotted. The forces are transferred to the composite in the shear span and are zero in the mid region where the moment is constant and is largest at the ends where the movements were largest in the beginning.

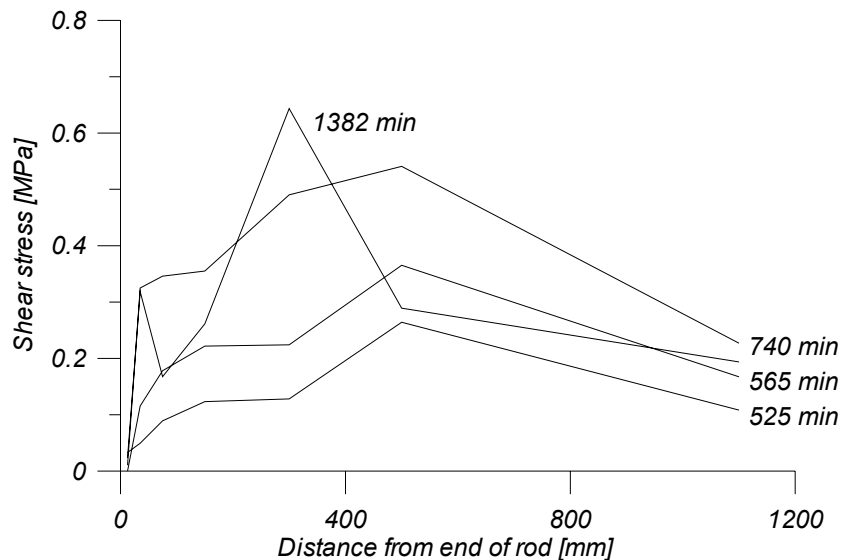

**FIG. 9.** The strains in the composite for the peak load during curing, *BSdyn*.

The first three plots (*525, 565, and 740 min*) in FIG. 9 show that the shear stresses become higher at the end of the rod as the epoxy hardens. The last plot, *1382 min*, shows a scattered behavior, which most likely depends on cracks between the strain gauges. However, there is a clear tendency that the shear stress increases with setting of the adhesive. The explanation for this is that the shear stress in the bond layer is proportional to the stiffness of the adhesive, (Täljsten 1997), and when the epoxy hardens, the viscosity and Young's modulus of the adhesive increases. In FIG. 10 and FIG. 11, the composite strain and the viscosity of the two epoxies are shown.

Stage 2, when forces start to be transferred to the composite, begins at different times for the two epoxies but the viscosity is about the same. Stage 2 changes from a viscosity of about  $10^6$  Pas to a viscosity of  $10^8$  Pas. When the viscosity is below  $10^6$  Pas, the shear modulus of the adhesive is too low to transfer the strains in the concrete into the CFRP. When the viscosity is above  $10^8$  Pas, further increase of the shear modulus does not affect the strain in the CFRP, i.e. the shear modulus is high enough to give full bond for the applied strains.

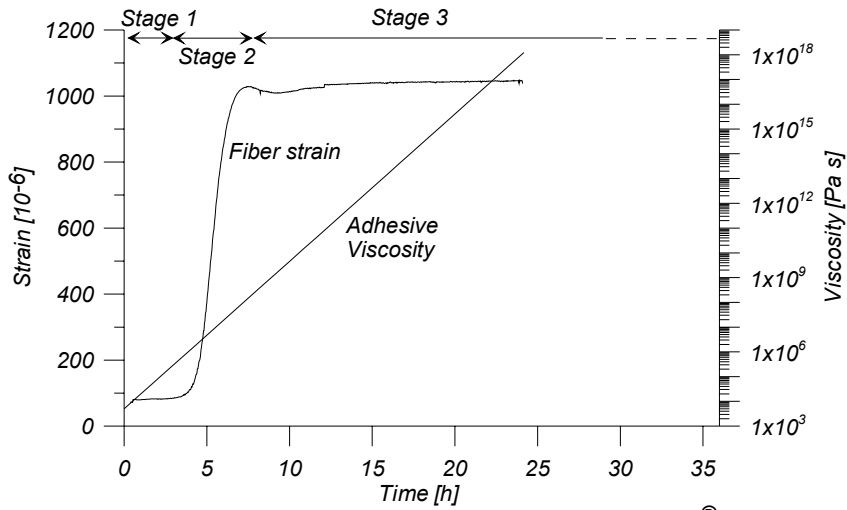

**FIG. 10.** Strains in composite (*BShdyn*) and viscosity of BPE<sup>®</sup> Lim 567 over time.

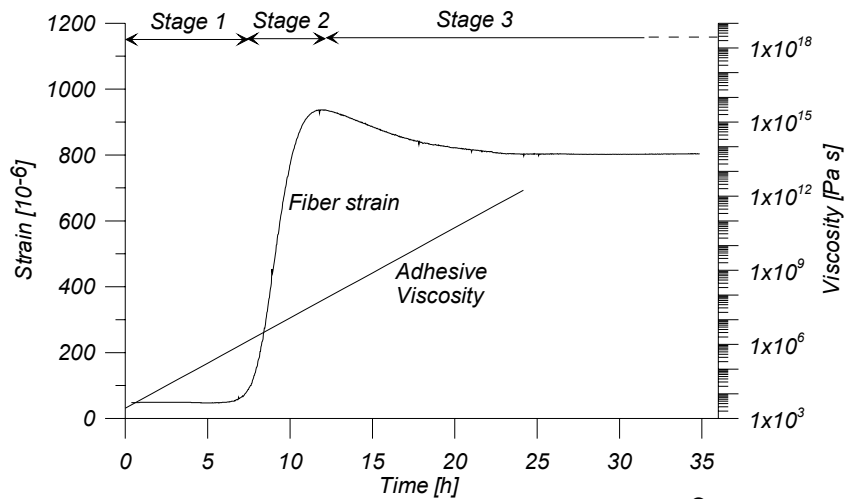
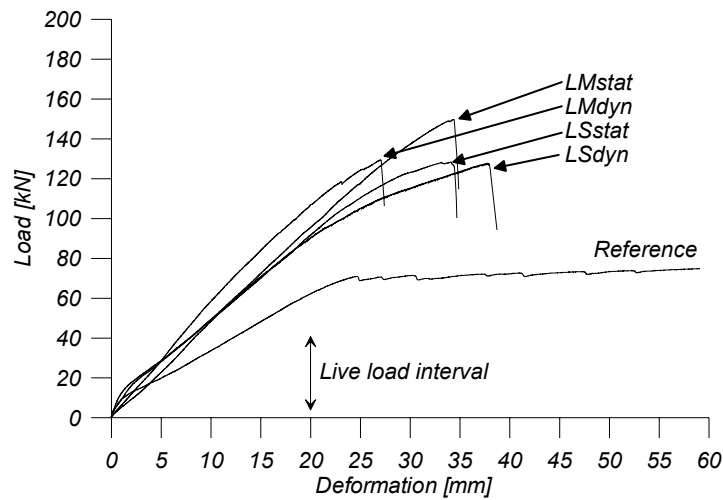

**FIG. 11.** Strains in composite (*BSdyn*) and viscosity of BPE<sup>®</sup> Lim 465 over time.

### ***Load-carrying capacity tests***

The beams were subjected to four-point loading, (as presented in FIG. 2), by deformation control, with a rate of  $0.01 \text{ mm/s}$ . The control beam, *Reference*, has a high initial stiffness until the concrete cracks, see (FIG. 12) where all the load deflection plots for beams strengthened with laminates are shown.





**FIG. 12.** Load-deflection plots for the laminate plate bonded beams

After cracking of concrete, the beam is linear elastic until yielding of the internal steel bars starts. After initiation of yielding, the loading continued until large deformations were present. The beams subjected to live loads during the curing of the adhesive were already cracked before the load ramp to failure started. The typical behavior of these beams is linear elastic until yielding of internal steel is reached. Then the stiffness is reduced but the beams carry more load until failure. Beams not subjected to live loading are uncracked and therefore have an initial stiffness that is higher than the precracked beams. After cracking the behavior is similar for all the beams. In Table 6 test results for all beams are summarized.

After ultimate load was reached for the strengthened beams the capacity decreased to the level of the control beam. FIG. 12 shows in general that strengthening with bonded carbon fiber laminates is an effective strengthening method both regarding ultimate load and load when internal steel yields. What is even more interesting is that the dynamic loads during curing do not significantly affect the strengthening effect. However, depending on type of failure the ultimate load capacities are not the same for S and M laminates, where the M laminates with a higher Young's modulus reached failure by peeling and the S laminates by laminate strain failure. The beams strengthened with laminates failed by anchorage failure in the concrete for both laminates *LSstat*, *LSdyn* and *LMdyn*, (see FIG. 13), except for beam *LMstat* that failed by rupture of one of the laminates and anchorage failure in the other.

**Table 6.** Summarized Results of Test to Failure

	Ultimate Load [kN]	Deflection at Ultimate Load [kN]	Failure Description
Reference beam	72*	24*	Yielding and large deformation
<i>Plate bonding</i>			
LMstat	150	34	Fiber rupture in one rod. Anchor failure in the other
LMdyn	129	27	Anchor failure in the concrete
LSstat	127	34	Anchor failure in the concrete
LSdyn	127	38	Anchor failure in the concrete
<i>NSMR</i>			
BMstat	169	42	Anchor failure in the concrete
BMdyn	180	44	Fiber rupture in one rod. Anchor failure in the other
BSstat	177	63	Bond slip
BSdyn	171	60	Bond slip
BShdyn	164	58	Anchor failure in the concrete
BSstat-cem	157	48	Fiber rupture in one rod. Anchor failure in the other
BSdyn-cem	80*	22*	Bond slip. Yielding and large deformation

\*) at initiation of yielding

**FIG. 13.** Anchorage failure in the concrete for beam *LSstat*.

This may be an indication that the anchorage is affected by the dynamic curing condition for high modulus fibers. The load deflection plots for the beams strengthened by NSMR and epoxy are shown in FIG. 14.

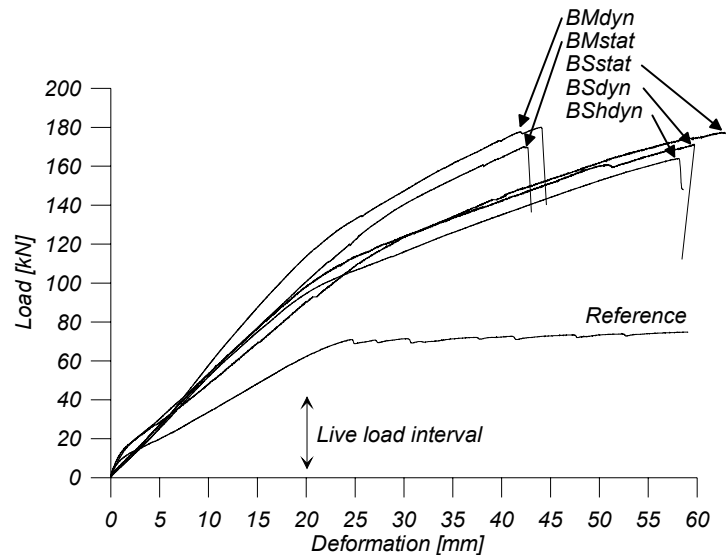

**FIG. 14.** Load-deflection plots for the NSMR strengthened beams.

The higher strengthening effect from NSMR compared to traditional laminate bonding is most likely due to the applied area of strengthening material. FIG. 14 shows in general that strengthening with NSMR is an effective strengthening method. It also shows that the dynamic loads during the curing of the epoxy do not affect the strengthening. Beam *BMdyn* failed by fiber rupture in one rod and anchorage failure in the concrete for the other rod. Beam *BMstat* failed by severe concrete damage where the part of the concrete beneath internal steel was detached, (see FIG. 15). The other beams failed by normal anchorage failure in the concrete. FIG. 16 shows that a cementitious mortar also works as bonding agent when the beam is strengthened while unloaded.

In fact, it is possible to achieve the same capacity with cement as with epoxy. It is also obvious that the same mortar is not useful if dynamic loads during the strengthening are prevailing. Beam *BSdyn-cem* behaved like the *Reference* beam. Even if the rods were almost loose in the groove, the roughness from the quartz sand was able to transfer forces to the rods that actually became stressed. After the steel started to yield, the strain in the rods remained at the same level as the deformation of the beam increased. Beam *BSstat-cem* failed by fiber rupture in one of the rods.



**FIG. 15.** Anchorage failure in the concrete for *BMstat*.

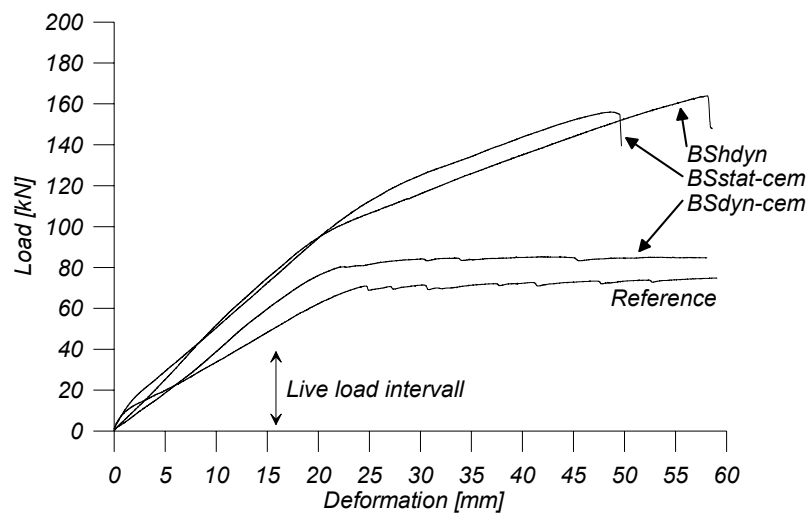

**FIG. 16.** Load-deflection plots for the NSMR strengthened beams with cement adhesive.

## Conclusions

For the beams strengthened by laminate plate bonding or NSMR with epoxy, the cyclic loads do not significantly affect the strengthening effect for the tested beams. The small differences noticed in the tests can be due to normal scatter of the failure mode. However, the failures were controlled by anchorage in the concrete and the absolute effect on the bond behavior could not be directly studied from the load bearing capacity. The use of cementitious mortar together with NSMR is not suitable

when cyclic loads are prevailing during hardening of the adhesive. A cementitious bonding agent together with NSMR does work when it cures under static conditions. This pilot study with cyclic loads can be extended with different load levels and load frequency. The two tested epoxies show a difference in curing times, one epoxy is faster than the other. No other differences can be found between the two systems.

## Acknowledgements

For help with the laboratory tests special attention should be given to Håkan Johansson and Georg Danielsson at TESTLAB, Luleå University of Technology. The assistance of Professor Lennart Elfgren is also greatly appreciated. BPE® Systems AB has been helpful by providing with material properties and expertise in strengthening systems. The Development Fund of the Swedish Construction Industry, SBUF and Swedish Road Authorities has provided financial support for the tests. Last but not least the MSc. student Otto Norling should be thanked for his never-ending energy working with this project.

## References

- Blaschko, M. A. (2001): "Zum Tragverhalten von Beetonbauteilen mit in Schlitz eingeklebten CFK-Lamellen" Doctoral Thesis ISSN: 0941-925X, 150 pp In German.
- Carolin, A (2001): "Strengthening of concrete structures with carbon fibre reinforced polymers –Shear strengthening and full-scale applications" Licentiate thesis. Luleå University of Technology, Division of structural engineering. 118 pp
- Carolin, A., Nordin, H. and Täljsten, B. (2001): "Concrete beams strengthened with near surface mounted reinforcement of CFRP". *International Conference on FRP Composites in Civil Engineering*, Volume 2, J.-G. Teng (Ed). ISBN: 0-08-043945-4 pp 1059-1066
- Carolin, A. and Täljsten, B. (2002): "Behavior of concrete beams strengthened with near surface mounted reinforcement, NSMR", *Proceedings of ACIC2002*, Southampton, April 2002. 9 pp.
- Chaallal, O., Nollet, M.-J., and Perraton, D. (1998): "Strengthening of reinforced concrete beams with externally bonded fiber-reinforced-plastic plates: Design guidelines for shear and flexure", *Canadian Journal of Civil Engineering*, pp. 692-704
- Enochsson, O., Hejll, A., Nilsson, M., Thun, H., Olofsson, T. and Elfgren, L. (2002): "Bridge over Luossajokk. Design by probabilistic method." Luleå University of Technology, Structural Engineering, Technical Report, 98 pp (in Swedish)
- Hejll, A. Carolin, A. and Täljsten, B. (2003): "Strengthening with CFRP during simulated live loads" To be published at *FRPRCS-6*, Singapore, July
- Karbhari, V. and Seible, F. (1999): "Fibre-Reinforced Polymer Composites for Civil Infrastructure in the USA", *Structural Engineering International, Journal of the IABSE*, V. 9 No. 4, November pp.274-277.
- Meier, U et al (1993): "CFRP bonded sheets". Editor Nanni, A., Amsterdam: Elsevier. ISBN 0-444-89689-9. pp 423-434.

- 
- Nanni, A. (2001): "North American design guidelines for concrete reinforcement and strengthening using FRP: Principles, applications and unresolved issues" *International Conference on FRP Composites in Civil Engineering*, Volume 1, J.-G. Teng (Ed). ISBN: 0-08-043945-4 pp 61-72
- Nordin, H., Täljsten, B. and Carolin, A. (2001): "Concrete beams strengthened with prestressed near surface mounted reinforcement (NSMR)" *International Conference on FRP Composites in Civil Engineering* Volume 2, J.-G. Teng (Ed). ISBN: 0-08-043945-4 pp 1067-1075
- Rizkalla, S. and Hassan T. (2001): "Various FRP strengthening techniques for retrofitting concrete structures" *International Conference on FRP Composites in Civil Engineering*, Volume 2, J.-G. Teng (Ed). ISBN: 0-08-043945-4 pp 1033-1040
- Täljsten, B. (1994): "*Plate bonding, Strengthening of existing concrete structures with epoxy bonded plates of steel or fibre reinforced plastics*" Doctoral Thesis 1994:152 D, Luleå University of Technology. Division of Structural Engineering. August 1994. 290 pp
- Täljsten, B., (1997): "Strengthening of beams by plate bonding", *J. of Materials in Civil Engineering*, November 1997, 206-212.
- Täljsten, B. and Carolin, A. (1999): "*Strengthening of a railroad bridge. Before and after strengthening*" Technical report. Luleå University of Technology, Division of structural engineering. 61 pp
- Täljsten, B. and Carolin, A. (2001): "CFRP - Strengthening. Concrete Beams Strengthened with Near Surface Mounted CFRP Laminates" *Fibre reinforced plastics for reinforced concrete structures, FRPRCS-5*, Cambridge (Edited by Chris Burgoyne), pp 107-116.
- Täljsten, B. (2002): "*FRP Strengthening of existing concrete structures– design guidelines*". Luleå University of Technology, Division of structural engineering. ISBN 91-89580-03-6. 227 pp
- Weijian, Y. and Huiming, H. (2001): "Experimental study on the flexural behavior of RC beams strengthened with CFRP laminates" *International Conference on FRP Composites in Civil Engineering*, Volume 1, J.-G. Teng (Ed). ISBN: 0-08-043945-4 pp 399-405

## **APPENDIX E – PAPER V**

“Stability improvement of axially loaded  
steel members by CFRP strengthening”

by Anders Carolin<sup>1</sup>, Björn Täljsten<sup>1,2</sup> and Lars Åström<sup>3</sup>

<sup>1</sup>) Luleå University of Technology  
Division of Structural Engineering  
SE-971 87 Luleå  
Sweden

<sup>2</sup>) Skanska Teknik AB  
SE-169 83 Solna  
Sweden

<sup>3</sup>) Luleå University of Technology  
Division of Structural Testing  
SE-971 87 Luleå  
Sweden

Submitted for publication in

*Steel & Composite Structures – An International Journal*





## **Stability improvement of axially loaded steel members by CFRP strengthening**

*Tech.Lic. M.Sc. Anders Carolin, Luleå University of Technology, SE-971 87 SWEDEN*

*Dr. Prof. Björn Täljsten, Luleå University of Technology, SE-971 87 SWEDEN  
and  
Skanska AB, SE-169 83 SWEDEN*

*Tech. Lars Åström, Luleå University of Technology, SE-971 87 SWEDEN*

### ***Corresponding author***

*Anders Carolin,  
Luleå University of Technology,  
Division of Structural Engineering  
SE-971 87 SWEDEN*

*Anders.Carolin@ce.luth.se*

### **Abstract**

*The need for strengthening and retrofitting is well known and extensive research is progressing in this field. The reasons for strengthening and retrofitting are numerous: increased loads, changes in use, deterioration, and so on. In recent years, the use of Fibre Reinforced Polymer (FRP) for strengthening has shown to be a competitive method, both regarding structural performance, and economical aspects. Extensive research has been carried out in this field. However, most of the research has been undertaken on concrete structures and for confinement, flexural, and shear strengthening. Limited research has been carried out on steel structures strengthened with FRP, and to the authors knowledge, no research on axially loaded steel members has been presented. However, this paper presents axially loaded steel members strengthened for increased load and improved stability. The topic is studied theoretically and through laboratory tests. The theory covers analytical methods and a numerical FE-analysis. Carbon and Aramid fibre reinforced polymers have been used to strengthen the members. The tests have been undertaken on full-scale specimens, non-strengthened for reference, partially strengthened and fully strengthened.*

## Introduction

Axially loaded members can be found almost everywhere. Trusses, that are used for bridges, masts and beams, consist of many members subjected to more or less pure compression. Slender members subjected to compression should be designed to carry the load requirement without failing by yielding or instability, i.e. buckling. However, it is not unusual that the demands are changed, for example increased loads or change in use. The knowledge regarding structural behaviour has improved and sometimes led to higher safety factors. In addition structures may be affected by accidents, or be insufficient either due to incorrect design, or faults during construction. If the function of a structure becomes inadequate, for example by one of the above reasons, it might be possible to keep it in service with restrictions of use. Otherwise, the structure has to be repaired, replaced or strengthened. In every case, it should be determined whether it is more economical to strengthen the existing structure, compared to replacement. With environmental and economical aspects in mind, it is untenable to always replace a structure. The optimum action to take may be an administrative upgrading, where refined calculation methods are used in combination with material parameters tested from the structure, to show that the existing structure has a higher load-carrying capacity compared to earlier assumptions.

If a steel member subjected to compression needs to be strengthened, many methods exist. For example, extra material can be welded or bolted to the cross section, pipes can be filled with concrete or the buckling length can be shortened. These methods have been proven to work well in many situations. However, they can, in some cases entail drawbacks that make the method too expensive or ineffective over time. Due to the different advantages and drawbacks of the methods, designers must closely evaluate all strengthening alternatives, including the possibility that replacement instead of upgrading may be the best choice. In the future, strengthening will likely be even more common as new methods are developed and as the knowledge on environmental aspects and life cycle cost increases.

One method that has become an established method for strengthening existing concrete structures is to bond fibre composite materials to their surfaces, (Cheng *et al.* 2002, Teng *et al.* 2001 and Carolin 2001). The most common materials to be used are carbon and aramid fibres in combination with epoxy resin. These materials offer not only a high strength to weight ratio, but also corrosion resistance and excellent fatigue behaviour, (Hull and Clyne 1996). The method has also been used for flexural strengthening of steel bridges, (Sen *et al.* 1995). Since the strengthening method does not necessitate any heavy equipment during the application process, it is suitable to use at high heights and in narrow places.

In this study the possibility of using fibre composites for increasing the global buckling load for steel pipes subjected to pure compression has been investigated. The

work includes a theoretical study as well as full-scale tests. The theoretical work consists of both analytical and numerical finite element calculations.

## Theory

For the theories, Young's modulus,  $E$ , and moment of inertia,  $I$ , of the involved materials are needed. The Young's modulus for steel is well known. For the composite the modulus is dependent on the fibre content. The moment of inertia is only dependent on geometry and for a pipe with notations as in Fig. 1 it is calculated in accordance to Eq. (1).

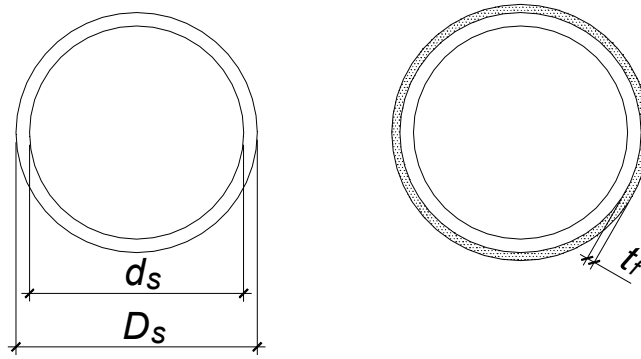

Fig. 1: Cross-section of non-strengthened (left) and strengthened (right) member

$$I = \frac{\pi(D^4 - d^4)}{64} \quad (1)$$

For the strengthened members the modulus will vary over the cross-section and it is most convenient to calculate the product of Young's modulus and the moment of inertia,  $EI$ . Here we introduce the property  $(EI)_{str}$  of the strengthened cross-section which may be calculated as in, Eq. (2). This is possible since the two materials have the same centre of gravity, as it is in this case, and is based upon that plane cross-sections remain plane, (Popov 1990).

$$(EI)_{str} = E_{frp} \frac{\pi((D_s + 2t_{frp})^4 - D_s^4)}{64} + E_s \frac{\pi(D_s^4 - d_s^4)}{64} \quad (2)$$

By defining the Young's modulus for the FRP as a function of Young's modulus for steel as

$$E_{frp} = \alpha E_s \quad (3)$$

Eq. (2) may be written as:

$$(EI)_{str} = \frac{E_s \pi}{64} [\alpha (D_s + 2t_{fpp})^4 + D_s^4 (1 - \alpha) - d_s^4] \quad (4)$$

From Eq. (4), a fictitious moment of inertia,  $I_{str}^*$ , for the strengthened cross-section corresponding to a cross-section with Young's modulus for steel can be identified as

$$I_{str}^* = \frac{\pi}{64} [\alpha (D_s + 2t_{fpp})^4 + D_s^4 (1 - \alpha) - d_s^4] \quad (5)$$

A stiffness improvement constant,  $c$ , is defined as the stiffness of the strengthened cross-section in relation to the stiffness of the non-strengthened cross-section.

$$c = \frac{(EI)_{str}}{E_s I_s} = \frac{I_{str}^*}{I_s} = \frac{\alpha (D_s + 2t_{fpp})^4 + D_s^4 (1 - \alpha) - d_s^4}{(D_s^4 - d_s^4)} \quad (6)$$

### Analytical Analysis

The critical stability load for a member with uniform stiffness over its whole length can easily be analytically described by the Euler formula, Eq. (7). The stiffness is uniform for a member without strengthening and a member with uniform strengthening over the whole length. For a hinged member with length,  $L$ , the critical load,  $P_{cr}$ , can be described by Euler mode 2, (Hsieh 1988).

$$P_{cr} = \frac{\pi^2 EI}{L^2} \quad (7)$$

However, an examination of the bending-moment diagram for a buckled truss member indicates that a uniform cross section along the length is not the most economical form for strengthening for increased stability. The greater part or the strengthening material should be applied in the midsection of the truss. The buckling mode of a truss member with higher moment of inertia in the midsection, shown in Fig. (2a), is presented in Fig. (2b). By comparing Fig. (2b) and Fig. (2c), it is found that the member can be studied as in Fig. (2d).

By using an energy approach, the critical load for a member, as in Fig. (2d), may be analytically determined. The internal work to deform the truss as in Fig. (2c) may be expressed as:

$$\Delta U = \int_0^L \frac{M^2}{2EI} dx \quad (8)$$

where  $M = Py$  The deformation of the buckled truss member is approximated by

$$y = \delta \cos\left(\frac{\pi x}{L}\right) \quad (9)$$

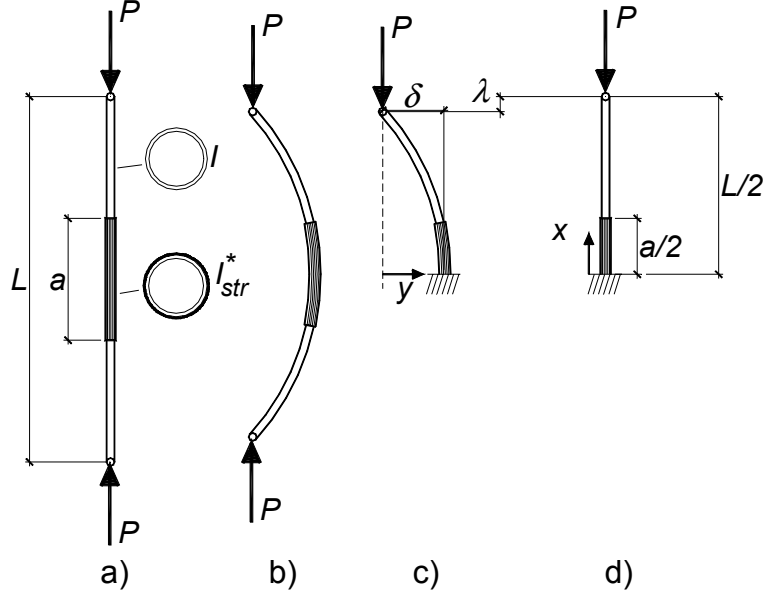

Fig. 2: Truss element partially strengthened

By combining Eqs. (8) and (9) and with notations as in Fig. (2d) the internal work becomes

$$\Delta U = \frac{P^2 \delta^2}{2E_s I_{str}^*} \left( \int_b^a \cos^2 \left( \frac{\pi x}{L} \right) dx + \frac{I_{str}^*}{I_s} \int_{\frac{L}{2}}^L \cos^2 \left( \frac{\pi x}{L} \right) dx \right) \quad (10)$$

The vertical deformation,  $\lambda$ , is described by (Timoshenko and Gere 1961) as:

$$\lambda = \frac{1}{2} \int_b^L \left( \frac{dy}{dx} \right)^2 dx = \frac{\delta^2 \pi^2}{8L} \quad (11)$$

and the external work to move the end of the truss the distance  $\lambda$  becomes:

$$\Delta T = \frac{P \delta^2 \pi^2}{8L} \quad (12)$$

For energy equilibrium the internal and external work must be equal:

$$\Delta U = \Delta T \quad (13)$$

and the critical load for the member may be written as:

$$P_{cr} = \frac{\pi^2 E_s I_{str}^*}{L^2} \frac{1}{\frac{a}{L} + \frac{L-a}{L} \frac{I_{str}^*}{I_s} - \frac{1}{\pi} \left( \frac{I_{str}^*}{I_s} - 1 \right) \sin \frac{\pi a}{L}} \quad (14)$$

Eq. (14) only describes a member with two cross-sections where one is located in the centre with the other symmetrically placed on both sides. The equation can neither be used for members with many changes in stiffness nor members with non-symmetrical stiffness.

### FE- analysis

Sometimes truss members may have installations in the midsection which make strengthening in the centre complicated or impossible. This means that the strengthening needs to be split into two parts with a gap between, or that the strengthening must be applied somewhat dislocated from the centre. It is possible to derive equations for any strengthening configuration. However, the expressions start to be complicated already with just one change in cross-section as presented above in Eq. (14). To solve the problem with non-uniform cross-section or non-symmetrical strengthening a numerical approach is suggested. The relationship between forces and deformations is the stiffness matrix,  $[k]$ , as shown in Eq. (15) with notations as shown in Fig. 3 where  $R_i$  denotes forces and moments. Displacements and rotations are denoted by  $r_i$ .

$$\begin{Bmatrix} R_1 \\ R_2 \\ R_3 \\ R_4 \end{Bmatrix} = [k] \begin{Bmatrix} r_1 \\ r_2 \\ r_3 \\ r_4 \end{Bmatrix} \quad (15)$$

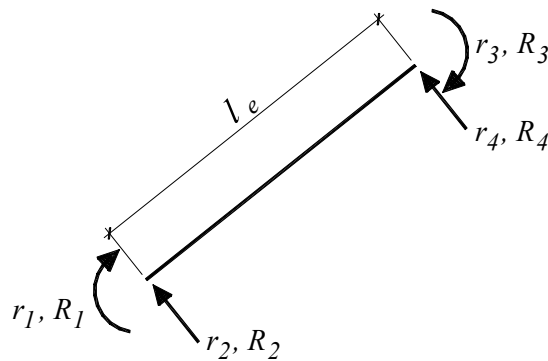

Fig. 3: Notations for truss element

The symmetric stiffness matrix for a truss element loaded with axial load  $P$  and length  $l_e$  can be described as Eq. (16) (Hsieh 1988):

$$[k_e] = \frac{EI}{l_e} \begin{bmatrix} 4 & & & & & \\ -\frac{6}{l_e} & \frac{12}{l_e^2} & & & & \\ 2 & -\frac{6}{l_e} & 4 & & & \\ \frac{6}{l_e} & -\frac{12}{l_e^2} & \frac{6}{l_e} & \frac{12}{l_e^2} & & \\ & & & & & \\ & & & & & \end{bmatrix} - P \begin{bmatrix} \frac{2l_e}{15} & & & & & \\ \frac{1}{10} & \frac{6}{5l_e} & & & & \\ -\frac{1}{l_e} & -\frac{1}{10} & \frac{2l_e}{15} & & & \\ \frac{30}{1} & \frac{10}{6} & \frac{15}{1} & \frac{6}{5l_e} & & \\ \frac{1}{10} & -\frac{6}{5l_e} & \frac{1}{10} & \frac{6}{5l_e} & & \end{bmatrix} \quad (16)$$

For the calculations nine elements have been used. Instability occurs when the load is increased to such a level that singularity occurs for the stiffness matrix, i.e. buckling of the member occurs when the determinant of the stiffness matrix is no longer positive.

## Tests

To investigate if steel pipes can be strengthened for improved stability with FRP bonding, full-scale tests have been undertaken. The tests also serve to investigate the accuracy of the analytical and numerical models presented in this paper. Four pipes have been strengthened and tested. Another pipe served as a reference specimen and was not strengthened. The length of all the steel pipes was 3800 mm. The outer diameter was 88.9 mm and the thickness 3.2 mm. The steel was of S235JRG2 quality, which has a Young's modulus of 210 GPa and a yield stress of 235 MPa. The steel pipes were manufactured from flat steel plates that were bent and welded. When two pipes were placed parallel to each other, no initial deformation could be detected by the naked eye. The ends were cut by turning cutting and can be considered plane and perpendicular to the length of the pipe. One pipe was strengthened along almost the whole length, the other were only partially strengthened as shown in Fig. 4. The reason for partial strengthening is that strengthening is most efficient at the mid-section. One partial strengthening was divided into two parts for one of the members.

The beams were labelled first with a letter representing the strengthening material,  $C$  for carbon and  $A$  for aramid, followed by the length of the strengthening in  $mm$  as shown in Table 1. The material data for used materials are presented in Table 2.

In all cases, five 0.3 m wide unidirectional fibre sheets were applied. The fibre amount is  $200 \text{ g/m}^2$  per sheet for carbon and  $300 \text{ g/m}^2$  per sheet for aramid. This resulted in a composite thickness of 2.9 mm for carbon and 5.2 mm for aramid, calculated as an average from 20 points around the perimeter. All fibres have been placed in the longitudinal direction of the pipe.

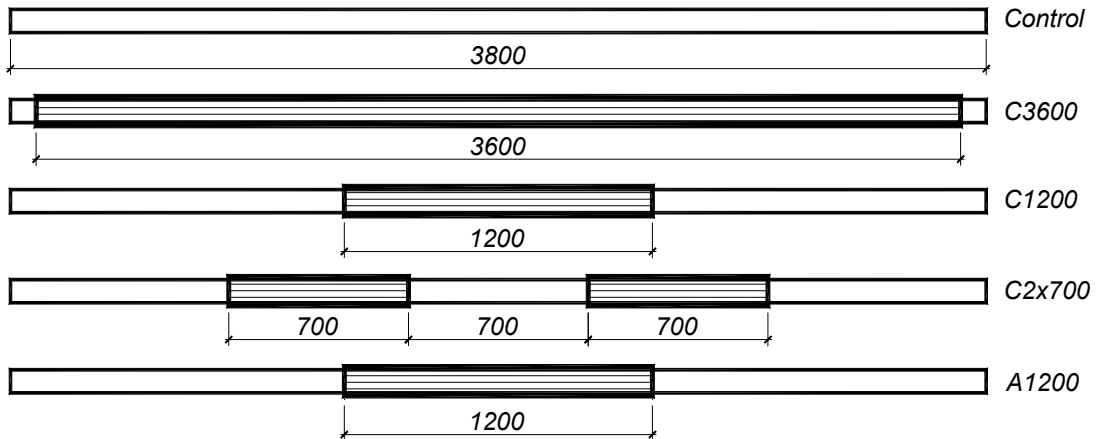

Fig. 4: Test specimens

Table 1: Test specimens

	Fibre type	Length of strengthening [mm]
Control	-	-
C3600	Carbon	3600
C1200	Carbon	1200
C2x700	Carbon	2x700
A1200	Aramid	1200

Table 2: Material data

	Young's modulus [GPa]	Failure strain [10 <sup>-3</sup> ]	Failure stress [MPa]	Density [10 <sup>3</sup> kg/m <sup>3</sup> ]
Steel	210	1.1*	235*	
Carbon	234	17	4500	1.80
Aramid	115	25	2900	1.45
Epoxy	2.6	30	-	

\*) Yielding

The hand lay-up technique has been used to apply the sheets. Hand lay-up means that dry sheets are bonded to the steel surface with an adhesive, which also wets the fibres. The process is repeated depending on the number of sheets needed. This technique normally gives a fibre content by volume of 25-35 %, (Täljsten 2002). In preparation of the specimens, more adhesive than normal was used and the measured fibre content



was approximately 20-25 %. Normally, in composite applications, it is desirable to have high fibre content. In this case low fibre content implies a thicker cross-section and for that reason, a higher contribution to the buckling resistance. The buckling resistance also becomes more prevalent the further from the neutral axis the fibres are placed as long as bond can be provided by the adhesive. Specimens *C3600* and *C1200* have a higher fibre content than *C2x700* and *A1200*. To be able to apply the load, two steel inserts one at each end of the truss member, were used. The buckling length of the members was increased by approximately 35 mm at both ends due to these bearings, see Fig. 5. The slot in the insert and the roller, forced the pipe to buckle in the chosen plane. The welds of the pipe were kept in the neutral axis for all the tests.

All specimens were equipped with strain gauges to monitor strain deformations. Four gauges were placed in the centre of the member. Two gauges were placed on each side of the neutral axis and two were placed in between these. Specimen *C1200* was equipped with two additional gauges in the neutral axis 800 mm from the centre. The members were tested vertically to minimize influence from gravitational transverse load. The test set-up after buckling of member *C3600* is shown in Fig. 6.

The members were subjected to a load-controlled loading of 0.167 kN/s (10kN/min), until buckling occurred. After buckling some additional deformation was applied with the actuator before the members were unloaded.

## Results

### Tests

At the beginning of the tests, the members only deformed by elastic compression and, as long as the applied load increased, nothing happened that was possible to detect by the eye. However, when the load caused buckling of the member, large “sudden” deformation took place and the load dropped. The ultimate capacities of the members when buckling occurred are presented in Table 3.

*Table 3: Buckling load from the tests.*

	<i>Load</i> [kN]	<i>Increase</i> [%]
Control	126.4	-
C3600	158.3	25
C1200	147.8	17
C2x700	151.8	20
A1200	156.6	24

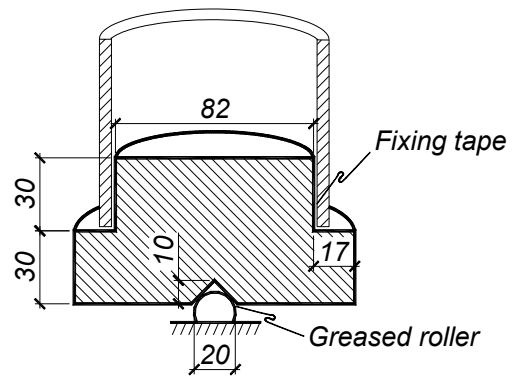

*Fig. 5: Hinged bearing*



*Fig. 6: Specimen C3600 after buckling.*

The average strains in neutral axis at mid-section versus load are presented in Fig. 7.

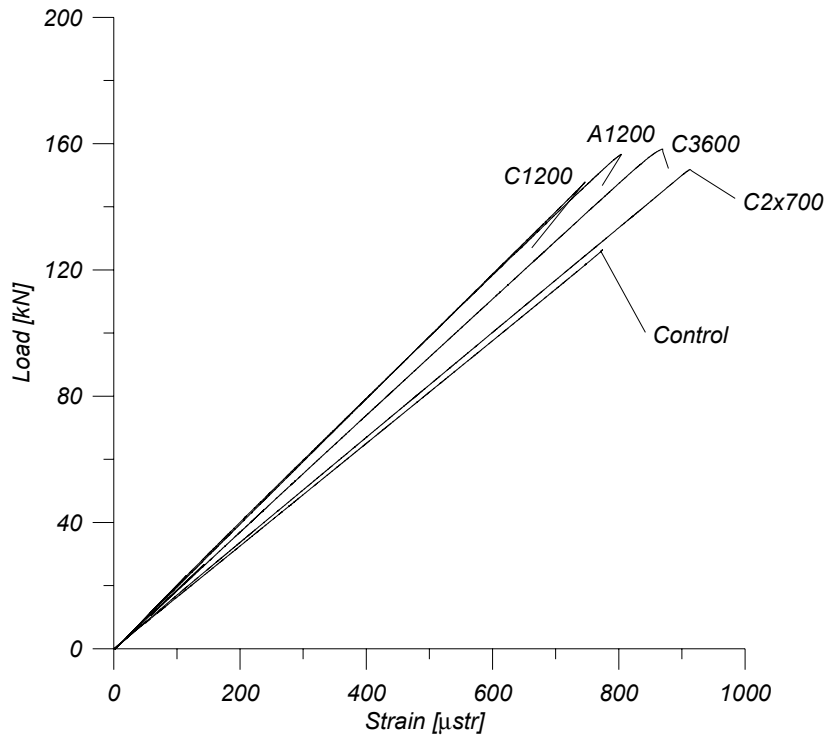

Fig. 7: Load versus average strain in neutral axis at mid section

The steel members behaved linear elastic until buckling occurred. On *Control* and *C2x700* the strain measurements have been measured on bare steel. Therefore it seems as if the stiffness of *C2x700* has not been affected by the strengthening. The strengthened sections, however, have been stiffer as can be seen on the other specimens. The buckling behaviour was strongly affected by the strengthening. A schematic deformation after buckling is presented in Fig. 8.

The *Control* specimen buckled typically in a smooth arc along the length of the pipe. This holds also for *C3600*, the difference is the maximum load, which was considerably higher for the strengthened pipe. After buckling *C3600* did recover better, i.e. the remaining deformation after unloading was smaller for *C3600* than for *Control*. Pipe *C1200* and *A1200* showed somewhat different behaviour. Due to the stiffer portion at mid-section the buckling deformation did occur just outside the strengthening on one side and was more concentrated. Pipe *C2x700* obtained its deformation at the mid-section and was more concentrated than *Control* member. The strengthened parts did not deform very much, instead the deformations were concentrated in the region between the two strengthening parts. The altered deformation schemes were possible to detect even after unloading due to plastic

deformations. In Fig. 9 are the strains on the most stressed sides (compression and tension), i.e. a measure of the rotation of the mid cross-section, presented. By studying the figure it can be observed that the members deform horizontally prior to buckling.

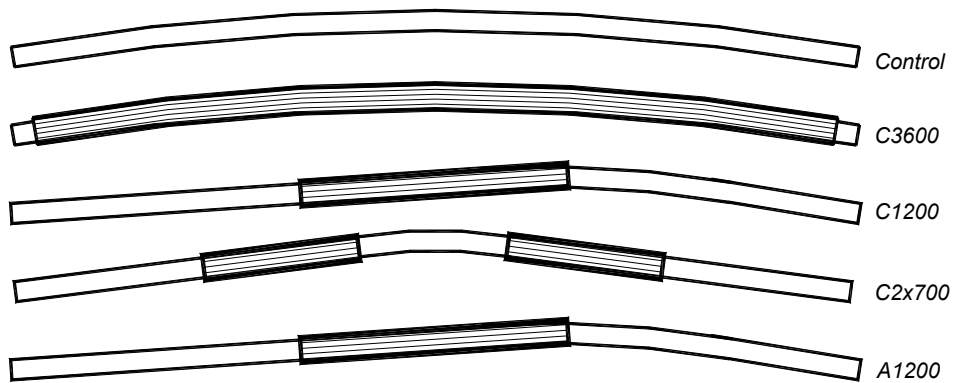

Fig. 8: Schematic buckling behaviour of the tested members

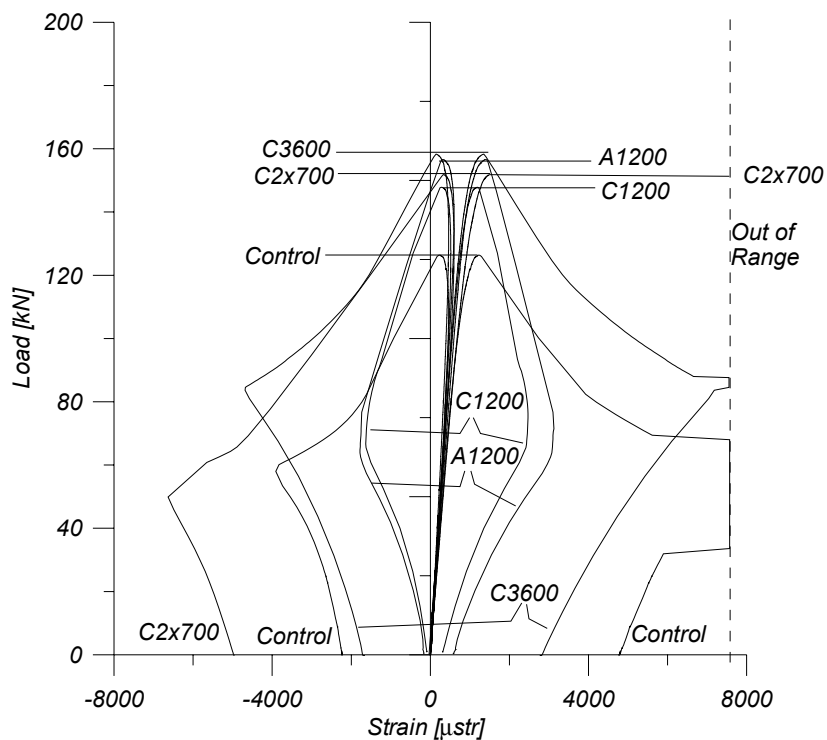

Fig. 9: Strains on the most stress sides (compression and tension).

This also show how buckling deformations have been forced away from the mid-section on specimens *C1200* and *A1200*, i.e. no plastic deformations at mid-section are measured when the members are unloaded. The concentration of deformation from pipe *C2x700* can also be identified from the strain measurements.

### Model results

The amount of carbon fibres used in the tests theoretically gives a thickness of 2.7 to 2.9 mm for fibre content from 22 % to 20 % by volume. For Aramid the thickness varies from 4.9 to 5.3 mm for the same fibre contents. The strengthening constant,  $c$ , has been calculated for different fibre content and composite thickness by Eq. (6) and is presented in Table 4 for carbon and Table 5 for aramid.

Table 4: Strengthening constant,  $c$ , as function of carbon fibre content,  $v_f$ , [%] and thickness  $t_f$  [mm].

	$t_f=2.5$	2.75	3	3.25	3.5
$V_f=18$	1.20	1.22	1.24	1.27	1.29
20	1.22	1.24	1.27	1.29	1.32
22	1.24	1.27	1.29	1.32	1.35
24	1.26	1.29	1.32	1.35	1.38

Table 5: Strengthening constant,  $c$ , as function of aramid fibre content,  $v_f$ , [%] and thickness  $t_f$  [mm].

	$t_f=4.5$	4.75	5	5.25	5.5
$V_f=18$	1.20	1.21	1.22	1.24	1.25
20	1.22	1.23	1.25	1.26	1.27
22	1.24	1.25	1.27	1.28	1.30
24	1.26	1.27	1.29	1.31	1.32

The theoretical thickness and the fibre content for the strengthened members, together with Table 4 and Table 5, gives the same strengthening constant, 1.26, for both carbon and aramid. With the same amount of fibre but with a fibre content of 50 %, the strengthening constants become instead 1.24 for carbon and 1.23 for aramid.

### Analytical results

The critical buckling load for a non-strengthened pipe is calculated by Eq. (7) to 110 kN. The yield load for the pipe is 202 kN and should be seen as an upper limit for

strengthening. The critical buckling loads for different strengthening constants and strengthening lengths are calculated by Eq. (14) and presented in Table 6.

*Table 6: Critical buckling load as function of strengthening constant,  $c$ , and strengthening length,  $a$ .*

	$c=1.1$	1.3	1.5	1.7	2	2.5	3
a=0.5	112	116	120	122	126	129	132
0.7	113	119	124	128	133	139	143
1	115	124	131	137	145	155	163
1.2	116	126	136	143	154	167	177
1.5	117	130	142	153	167	186	202
2	119	136	152	167	188	yielding in compression prior to buckling	
2.5	120	140	159	178			
3	120	142	163	184			
3.6	121	142	164	186			
3.8	121	142	164	186			

It is more convenient to use the term strengthening effect as the ratio for the buckling load for strengthened member to control member. This strengthening effect is presented in Table 7 for different strengthening constants and lengths.

*Table 7: Strengthening effect as function of strengthening constant,  $c$ , and strengthening length,  $a$ .*

	$c=1.1$	1.3	1.5	1.7	2	2.5	3
a=0.5	1.02	1.06	1.09	1.12	1.15	1.18	1.20
0.7	1.03	1.09	1.13	1.17	1.21	1.27	1.31
1	1.05	1.13	1.19	1.25	1.32	1.42	1.48
1.2	1.05	1.15	1.24	1.31	1.40	1.52	1.62
1.5	1.07	1.19	1.30	1.39	1.52	1.70	1.84
2	1.08	1.24	1.39	1.52	1.72	yielding in compression prior to buckling	
2.5	1.09	1.27	1.45	1.62			
3	1.10	1.29	1.49	1.68			
3.6	1.10	1.30	1.50	1.70			
3.8	1.10	1.30	1.50	1.70			

With a chosen strengthening length,  $a$ , Table 7 gives the strengthening effect for a certain strengthening constant. The table can also be used to identify the strengthening length needed to achieve a desired strengthening effect for different strengthening constants.

## FE-model

The FE-model gives a critical buckling load of 110 kN for the control member without any strengthening. The critical buckling loads are calculated for some different strengthening schemes. The loads from FE-model for the tested beams are presented in Table 8.

Table 8: Buckling loads from FE-model.

	$c=1.1$	1.3	1.5	1.7	2	2.5	3
a=1.2	116	126	135	143	152	164	173
3.6	121	142	164	186	y*	y*	y*
a=2 x 0.7	115	124	132	138	146	157	164

\*<sup>y</sup>yielding in compression prior to buckling

The calculated loads for some possible strengthening schemes are normalized with the theoretical buckling load for a non-strengthened member and are presented in Table 9.

Table 9: Strengthening effect as function of strengthening constant,  $c$ , and strengthening length,  $a$ .

	$c=1.1$	1.3	1.5	1.7	2	2.5	3
a=0.5	1.02	1.06	1.09	1.11	1.14	1.17	1.20
0.7	1.03	1.09	1.13	1.17	1.21	1.26	1.29
1	1.05	1.13	1.19	1.25	1.31	1.39	1.45
1.2	1.05	1.15	1.23	1.30	1.39	1.50	1.58
1.5	1.07	1.19	1.29	1.38	1.50	1.66	1.79
2	1.08	1.24	1.38	1.52	1.70	yielding in compression prior to buckling	
2.5	1.09	1.27	1.45	1.62			
3	1.10	1.29	1.49	1.68			
3.6	1.10	1.30	1.50	1.70			
3.8	1.10	1.30	1.50	1.70			
a=2 x 0.7	1.05	1.13	1.20	1.26	1.33	1.43	1.50

## Comparison

The analytical model and the FE-model give the same results for the non-strengthened member, 110 kN. This corresponds relatively well with the test, 126 kN. The theoretical calculated thickness for a fibre content of 20 % by volume shows good agreement with the measured thickness. This thickness and fibre content gives a strengthening constant,  $c$ , of 1.26. The analytical model gives values 1-3 % higher compared to FE-model for strengthening constants of 2 and above. The reason for this

difference is the divergence between real and approximated buckling deformation Eq (9) for a non-uniform member. For strengthening constant 1.26 both models give the same load. The absolute loads for the strengthened members are quite well described by the models. However, if the strengthening effect is studied the agreement between tests and models is even better. As presented in Table 10 the strengthening effect differs by a maximum of 8 % for carbon and 9 % for aramid.

*Table 10: Buckling loads from FE-model.*

	<i>Test Load [kN]</i>	<i>Test Effect [-]</i>	<i>Model c=1.26 [kN]</i>	<i>Model c=1.26 [-]</i>	<i>Testratio/ modelratio [-]</i>
Control	126	-	110	-	1
C36	158	1.25	138	1.26	0.99
C12	148	1.17	124	1.13	1.03
C7-7	152	1.20	122	1.12	1.08
A12	157	1.24	124	1.13	1.09

The strengthening effect, i.e. the strengthening constant, is not so sensitive to changes in fibre content. However, within reasonable limits, lower fibre content gives a slightly higher strengthening effect, since the outer diameter and moment of inertia of the member will increase with decreasing fibre content. By reasonable limits, it is meant that the fibre content must be high enough so that the matrix will fully transfer the forces to the outmost fibres

## Discussion and conclusions

The theory and tests show that fibre composites can be used for strengthening of axially loaded truss members. Derived models may be used to calculate the strengthening effect. The fact that the tested member gives higher results than the tests can be due to friction at the hinged bearings. If more tests are undertaken it might be possible to prove that derived models can be used to calculate the strengthening effect for different strengthening constants and also to design strengthening with regard to a desired strengthening effect. The tested method with hand lay-up works well in a laboratory environment, but might be difficult to employ on real structures. At heights, it is harder to handle the fibre sheets, especially if it is windy. For strengthening of real structures, pre-manufactured shells that can be bonded to the truss could be developed and tested. The shells would then be manufactured in a controlled environment by hand lay-up, vacuum infusion or by pultrusion. A procedure with shells will probably be more cost effective compared to hand lay-up at site.



## Acknowledgement

Dr. Lars Bernspång at the Division for Building mechanics has supported in the work of deriving the stiffness equations and most of all been very helpful with the Finite Element model. Also thanks to Ph.D. student Arvid Hejll for help with strengthening of the pipes.

## References

- Carolin, A (2001): “*Strengthening of concrete structures with carbon fibre reinforced polymers – Shear strengthening and full-scale applications*” Licentiate thesis. Luleå University of Technology, Division of structural engineering. ISBN 91-89580-01-X.
- Cheng, H., Sotelino, E. and Chen, W. (2002): “Strength estimation for FRP wrapped reinforced concrete columns” *Steel & Composite Structures, An Int. J.* **2**(1), 1-20.
- Hsieh (1988): “*Elementary theory of structures*” Prentice-Hall: New Jersey. ISBN 0-13-261504-5
- Hull and Clyne (1996): “*An Introduction to Composite Materials*”, Second Edition. Cambridge University Press. ISBN 0 521 38855 4.
- Popov, E. P. (1990): “*Engineering Mechanics of Solids*”. Prentice Hall, New Jersey, ISBN 0-13-279258-3.
- Sen, R., Liby, L., Spillet, K. and Mullins, G.(1995): “Strengthening steel composite bridge members using CFRP laminates”. *Non-metallic (FRP) Reinforcement for Concrete Structures*. Ed L. Taerwe. E&FN Spon, 551-558. ISBN 0 419 20540 3..
- Timoshenko and Gere (1961): “*Theory of elastic stability*”. 2<sup>nd</sup> edition. McGraw-Hill: New York.
- Teng, J., *et al.* (2001): “*FRP-Strengthened RC Structures*” John Wiley & Sons ISBN 0-471-48706-6
- Täljsten. B. (2002): “*FRP Strengthening of Existing Concrete Structures – Design Guidelines*” Luleå University of Technology. Structural Engineering. ISBN 91-89580-03-6



## APPENDIX F - GLOSSARY

**Adhesive** - Substance applied to mating surfaces to bond them together by surface attachment. An adhesive can be in liquid, film or paste form.

**Anisotropic** - Fibre directionality where different properties are exhibited when tested along axes in different directions.

**Aramid** - High-strength, high-stiffness aromatic polyamide fibres.

**Areal weight** - Weight of a fibre reinforcement per unit area or sheet or fabric

**Buckling** - A failure mode usually characterised by fibre deflection out of the plane rather than breaking because of composite action.

**CFRP** - Carbon Fibre Reinforced Polymer

**Carbon Fibre** - Fibre produced by high temperature treatment of an organic precursor fibre based on PAN (polyacrylonitrile) rayon or pitch in an inert atmosphere at temperatures about 980 °C. Fibres can be graphitised by removing still more of the non-carbon atoms by heat treating above 1650 °C.

**Coefficient of thermal expansion** - A material's fractional change in length corresponding to a given unit change of temperature.

**Composite** - A material that combines fibre and a binding matrix to maximise specific performance properties. Neither element merges completely with the other. Advanced polymer composites use only continuous oriented fibres in a polymer matrix.

**Corrosion resistance** - The ability of a material to withstand contact with ambient natural factors or those of a particular artificially created atmosphere, without degradation or change in properties.

**Cure** - To change the molecular structure and physical properties of a thermosetting resin by chemical reaction via heat and catalyst in combination with or without pressure.

- Debonding** - Local failure in the bond zone between concrete and the externally bonded reinforcement.
- Delamination** - Separation of layers in a laminate because of the failure of the adhesive, either in the adhesive itself or at the interface between the adhesive and the adherent. For pultruded composites, the separation of two or more layers or plies of reinforcing material within pultrusion.
- Dry fibre** - A condition in which the fibres are not fully encapsulated by resin during pultrusion.
- Durability** - The ability of a material to resist weathering action, chemical attack, abrasion and other conditions of service.
- Epoxy resin** - A polymer resin characterised by epoxied molecule groups.
- Fabric, non-woven** - A material formed from fibres or yarns without interlacing.
- Fibre** - A general term used to refer to filamentary materials. Fibre is often used synonymously with filament.
- Fibre content** - Amount of fibre in a composite expressed as a ratio to the matrix. Strength generally increases as the fibre content ratio increases.
- FRP** - Fibre Reinforced Polymer.
- GFRP** - Glass Fibre Reinforced Polymer
- Glass Fibre** - Reinforcing fibre made by drawing molten glass through brushings. The predominant reinforcement for polymer matrix composites. Known for its good strength, processability and low cost.
- Hand Lay-up** - A fabrication method in which reinforcement layers are placed in a mould or on a structure by hand, then cured in the formed shape.
- Hybrid composite** - A composite made with two or more types of reinforcing fibres.
- Impregnate** - To saturate the voids of a reinforcement with a resin manually or with a machine.
- Lamina** - A ply or layer of unidirectional composite or fabric.
- Laminate** - To unite layers of material with an adhesive. Also, a structure resulting from bonding multiple plies of reinforcing fibre or fabric.
- Lay-up** - Placement of layers of reinforcement in a mould.
- LVDT** - Linear Voltage Differential Transducer
- Matrix** - Binder material in which reinforcing fibres are embedded. Usually a polymer but may also be metal or ceramic.
- NSMR** - Near Surface Mounted Reinforcement

**PAN (polyacrylonitrile)** - Used as a base material or precursor in the manufacture of certain carbon fibres.

**Peel-ply** - Layer of material applied to a pre-preg lay-up surface that is removed from the cured laminate prior to bonding operations leaving a clean, resin rich surface ready for bonding.

**Pitch** - A high molecule weight material that is a residue from the destructive distillation of coal and petroleum products. Pitches are used as base materials for the manufacture of certain high-modulus carbon fibres.

**Polyester** - Unsaturated polyesters are manufactured by reacting glycols with either dibasic acids or anhydrides. Polyesters are normally cured at room temperature with a monomer such as styrene.

**Polymer** - Large molecule formed by combining many smaller molecules or monomers in a regular pattern.

**Pot life** - Length of time in which a catalysed thermosetting resin retains sufficiently low viscosity for processing.

**Primer** - A coating applied to a surface prior to the application of an adhesive to improve the performance of the bond. The coating can be a low viscosity fluid that is typically a 10 % solution of the adhesive in an organic solvent, which can wet out the adherent surface to leave a coating over which the adhesive can readily flow.

**Pultrusion** - An automated, continuous process for manufacturing composite rods and structural shapes having a constant cross-section. Roving and/or tows are saturated with resin and continuously pulled through a heated die, where the part is formed and cured. The cured part is then cut to length. For some applications, fabrics can be included into the profiles.

**Resin** - Polymer with indefinite and often high molecular weight and a softening or melting range that exhibits a tendency to flow when subjected to stress. As composite matrices, resin binds together reinforcement fibres.

**Sheet** - A material formed from fibres or yarns without interlacing.

**Stress Corrosion** - Preferential attack of areas under stress in a corrosive environment, where such an environment alone would not have caused corrosion.

**Stress Rupture** - The reduction of tensile strength due to sustained loading.

**Thermoplastic** - A composite matrix capable of being repeatedly softened by an increase of temperature and hardened by cooling.

**Thermosets** - Composite matrix cured by heat and pressure or with a catalyst into an infusible and insoluble material. Once cured thermosets cannot be returned to the uncured state.

**Thixotropic** - Materials that are gel-like at rest but fluid when agitated. Having high static shear strength and low dynamic shear strength at the same time. Losing viscosity under stress.

**Unidirectional** - A strip or fabric with all fibres oriented in the same direction.

**Vinylester** - A class of thermosetting resins containing esters of acrylic and/or methacrylic acids, many of which have been made from epoxy resins. Cure is accomplished, as with unsaturated polyesters, by co-polymerisation with other vinyl monomers, such as styrene.

**Viscosity** - Tendency of a material to resist flow. As temperature increases, the viscosity of most materials increases.

**Wet Lay-up** - Fabrication step involving application of a resin to dry reinforcement.

## DOCTORAL AND LICENTIATE THESES

Division of Structural Engineering, Luleå University of Technology

### Doctoral Theses

- Ulf Arne Girhammar (1980): *Dynamic Fail-Safe Behaviour of Steel Structures*. Doctoral Thesis 1980:060D. 309 pp.
- Kent Gylltoft (1983): *Fracture Mechanics Models for Fatigue in concrete Structures*. Doctoral Thesis 1983:25D. 210 pp.
- Thomas Olofsson (1985): *Mathematical Modelling of Jointed Rock Masses*. Doctoral Thesis 1985:42D.
- Lennart Fransson (1988): *Thermal ice pressure on structures in ice covers*. Doctoral Thesis 1988:67D. 161 pp.
- Mats Emborg (1989): *Thermal stresses in concrete structures at early ages*. Doctoral Thesis 1989:73D. 285 pp.
- Lars Stehn (1993): *Tensile fracture of ice. Test methods and fracture mechanics analysis*. Doctoral Thesis 1993:129D, September 1993, 136 pp.
- Björn Täljsten (1994): *Plate Bonding. Strengthening of existing concrete structures with epoxy bonded plates of steel or fibre reinforced plastics*. Doctoral Thesis 1994:152D, August 1994, 283 pp.
- Jan-Erik Jonasson (1994): *Modelling of temperature, moisture and stresses in young concrete*. Doctoral Thesis 1994:153D, August 1994, 227 pp.
- Ulf Ohlsson (1995): *Fracture Mechanics Analysis of Concrete Structures*. Doctoral Thesis 1995:179D, December 1995, 98 pp.
- Keivan Noghabai (1998): *Effect of Tension Softening on the Performance of Concrete Structures*. Doctoral Thesis 1998:21, August 1998, 150 pp.
- Gustaf Westman (1999): *Concrete Creep and Thermal Stresses. New creep models and their effects on stress development*. Doctoral Thesis 1999:10, May 1999, 301 pp.
- Henrik Gabrielsson (1999): *Ductility in High Performance Concrete Structures. An experimental investigation and a theoretical study of prestressed hollow core slabs and prestressed cylindrical pole elements*. Doctoral Thesis 1999:15, May 1999, 283 pp.
- Groth, Patrik (2000): *Fibre Reinforced Concrete - Fracture Mechanics Methods Applied on Self-Compacting Concrete and Energetically Modified Binders*. Doctoral Thesis 2000:04, January 2000, 214 pp.

- Hans Hedlund (2000): *Hardening concrete. Measurements and evaluation of non-elastic deformation and associated restraint stresses*. Doctoral Thesis 2000:25, December 2000, 394 pp ISBN 91-89580-00-1.
- Anders Carolin (2003): *Carbon Fibre Reinforced Polymers for Strengthening of Structural Members*. Doctoral Thesis 2003:18, June 2003, ISBN 91-89580-04-4. 190 pp.
- Martin Nilsson (2003): *Restraint Factors and Partial Coefficients for Crack Risk Analyses of Early Age Concrete Structures*. Doctoral Thesis 2003:19, June 2003, ISBN: 91-89580-05-2.
- Mårten Larson (2003): *Thermal Crack Estimation in Early Age Concrete – Models and Methods for Practical Application*. Doctoral Thesis 2003:20, June 2003, ISBN 91-86580-06-0. 190 pp



## Licentiate Theses

- Lennart Fransson (1984): *Bärförmåga hos ett flytande istäcke. Beräkningsmodeller och experimentella studier av naturlig is och av is förstärkt med armering*. Licentiate Thesis 1984:012L.
- Mats Emborg (1985): *Temperature stresses in massive concrete structures. Viscoelastic models and laboratory tests*. Licentiate Thesis 1985:011L, May 1985, rev November 1985, 163 pp.
- Christer Hjalmarsson (1987): *Effektbehov i bostadshus. Experimentell bestämning av effektbehov i små- och flerbostadshus*. Licentiate Thesis 1987:009L, October 1987, 72 p.
- Björn Täljsten (1990): *Förstärkning av betongkonstruktioner genom pålimning av stålplåtar*. Licentiate Thesis 1990:06L, May 1990.
- Ulf Ohlsson (1990): *Fracture Mechanics Studies of Concrete Structures*. Licentiate Thesis 1990:07L, May 1990, 8+12+18+7+21 pp.
- Lars Stehn (1991): *Fracture Toughness of sea ice. Development of a test system based on chevron notched specimens*. Licentiate Thesis 1991:11L, September 1990, 88 pp.
- Per Anders Daerga (1992): *Some experimental fracture mechanics studies in mode I of concrete and wood*. Licentiate Thesis 1992:12L, 1ed April 1992, 2ed June 1992, 81 pp.
- Henrik Gabrielsson (1993): *Shear capacity of beams of reinforced high performance concrete*. Licentiate Thesis 1993:21L, May 1993, 109 pp. 18 June.
- Keivan Noghabai (1995): *Splitting of concrete in the anchoring zone of deformed bars. A fracture mechanics approach to bond*. Licentiate Thesis 1995:26L, May 1995, 123 pp.
- Gustaf Westman (1995): *Thermal cracking in high performance concrete. Viscoelastic models and laboratory tests*. Licentiate Thesis 1995:27L, May 1995, 125 pp.
- Katarina Ekerfors (1995): *Mognadsutveckling i ung betong. Temperaturkänslighet, hållfasthet och värmeutveckling*. Licentiate Thesis 1995:34L, October 1995, 137 pp.
- Patrik Groth (1996): *Cracking in concrete. Crack prevention with air-cooling and crack distribution with steel fibre reinforcement*. Licentiate Thesis 1996:37L, October 1996, 128 pp.
- Hans Hedlund (1996): *Stresses in High Performance Concrete due to Temperature and Moisture Variations at Early Ages*. Licentiate Thesis 1996:38L, October 1996, 240 pp.

- Mårten Larson (2000): *Estimation of Crack Risk in Early Age Concrete. Simplified methods for practical use*. Licentiate Thesis 2000:10, April 2000, 170 pp.
- Bernander, Stig (2000): *Progressive Landslides in Long Natural Slopes. Formation, potential extension and configuration of finished slides in strain-softening soils*. Licentiate Thesis 2000:16, May 2000, 137 pp.
- Martin Nilsson (2000): *Thermal Cracking of young concrete. Partial coefficients, restraint effects and influences of casting joints*. Licentiate Thesis 2000:27, October 2000, ISSN 1402-1757, 267 pp.
- Erik Nordström (2000): *Steel Fibre Corrosion in Cracks. Durability of sprayed concrete*. Licentiate Thesis 2000:49, December 2000, 103 pp.
- Anders Carolin (2001): *Strengthening of concrete structures with CFRP – Shear strengthening and full-scale applications*. Licentiate thesis, June 2001, ISBN 91-89580-01-X 2001:01 120 pp
- Håkan Thun (2001): *Evaluation of concrete structures. Strength development and fatigue capacity*. Licentiate thesis 2001:25. June 2001, ISBN 91-89580-08-2, 164 pp
- Patrice Godonue (2002): *Preliminary Design and Analysis of Pedestrian FRP Bridge Deck*. Licentiate thesis 2002:18, 203 pp
- Jonas Carlswärd (2002): *Steel fibre reinforced concrete toppings exposed to shrinkage and temperature deformations*. Licentiate thesis 2002:33. August 2002.
- Anders Rönneblad (2003): *Product Models for Concrete Structures - Standards, Applications and Implementations*. Licentiate thesis 2003:22, June 2003
- Håkan Nordin (2003): *Fibre Reinforced Polymers in Civil Engineering - Flexural Strengthening of Concrete Structures with Prestressed Near Surface Mounted CFRP Rods*. Licentiate thesis 2003:25, June 2003
- Sofia Utsi (2003): *Self-Compacting Concrete - Properties of fresh and hardening concrete for civil engineering applications* Licentiate thesis 2003:19, June 2003